

AD32 Enhanced Touch TRACKER®¹ ADTT32E

With Video Matrix Switcher



About this Guide

This installation guide explains the procedures for installing Enhanced TOUCH TRACKER controllers with the Video Matrix Switcher. Other related documents are:

- Installation and Service Manual, 8000-1702-02
- Operator's Manual, 8000-2655-02

Note: Because customer requirements dictate the placement of TOUCH TRACKER components, your Sensormatic representative will supply this information separately.

If you need assistance...

Call Sensormatic Customer Support at:
1-800-543-9740

¹ TOUCH TRACKER, Sensormatic, and the Sensormatic logo are registered trademarks of Sensormatic Electronics Corporation. Other product names (if any) mentioned herein may be trademarks or registered trademarks of Sensormatic or other companies.

No part of this document may be reproduced in any form without written permission from Sensormatic Electronics Corporation.

© Copyright 1999. All rights reserved.

(CSD) 07/99

Parts Required

TOUCH TRACKER Installation Kit:

Part Number 0351-0474-07

INSTL KIT, TOUCH TRKR, W/RJ45 1

Description	Qty	Part No.
CABLE ASSY,MDLR,14FT,8 COND,CROSS-P	1	6003-0047-01
SCR,THD CUT,M2.9X9.5,PHP,ST,Z,T1	1	5899-0004-102
ANCHOR,PLASTIC,W/O SCREW,8-10	2	2880-0083-01
SCR,TYP AB,PHP,CAD,#8X1"	2	2816-7634-44
CONN,PLUG,TUBLR.,200CTR,26-12AWG,1X	1	2109-0254-04
LUG,SPADE,CRIMP,INSUL,22-16AWG	3	2141-0002
CABLE,3COND,18AWG,CM	16.5	6002-0024-01
INTERCONNECT BOX,TOUCHTRACKER	1	0300-1000-01
CABLE ASSY,TOUCH TRACKER,INTFC TO Q	1	0650-0932-01
HOOD,D-SUB,9POS,EMI/RFI,.25 DIA CAB	1	2125-0007-02
CONN,D-SUB,PLUG,HSG,9POS,SSI	1	2130-0021-01
FERRITE CORE	1	2700-0023-01
QUICK REFERENCE GUID	1	8000-2656-02
TOUCH TRACKER STRAIN RELIEF INSTR	1	8000-1370-01



WARNING Shock Hazard!

Disconnect AC Power.



CAUTION static sensitive components!

Follow proper handling procedures to prevent component failure.

Installation Procedures

See **Remote Switcher Location** for procedures when the Video Matrix Switcher will be more than 4m (14 ft) from the EIMs.

1. Attach each EIM to a wall or other surface within 3m (10 ft) of its TOUCH TRACKER controller.
2. Terminate the EIM that is at the end of the SensorNet network.

See Figure 1 for the wiring diagram for a typical 2-controller AD32 system installation. For more information on the SensorNet network, see the *SensorNet Network Guide* (PN 8000-0970-01).

3. Attach the 3 spade lugs to one end of the 3-conductor cable, then attach the lugs to the EIM power transformer.

Figure 1. VM32 Wiring Diagram

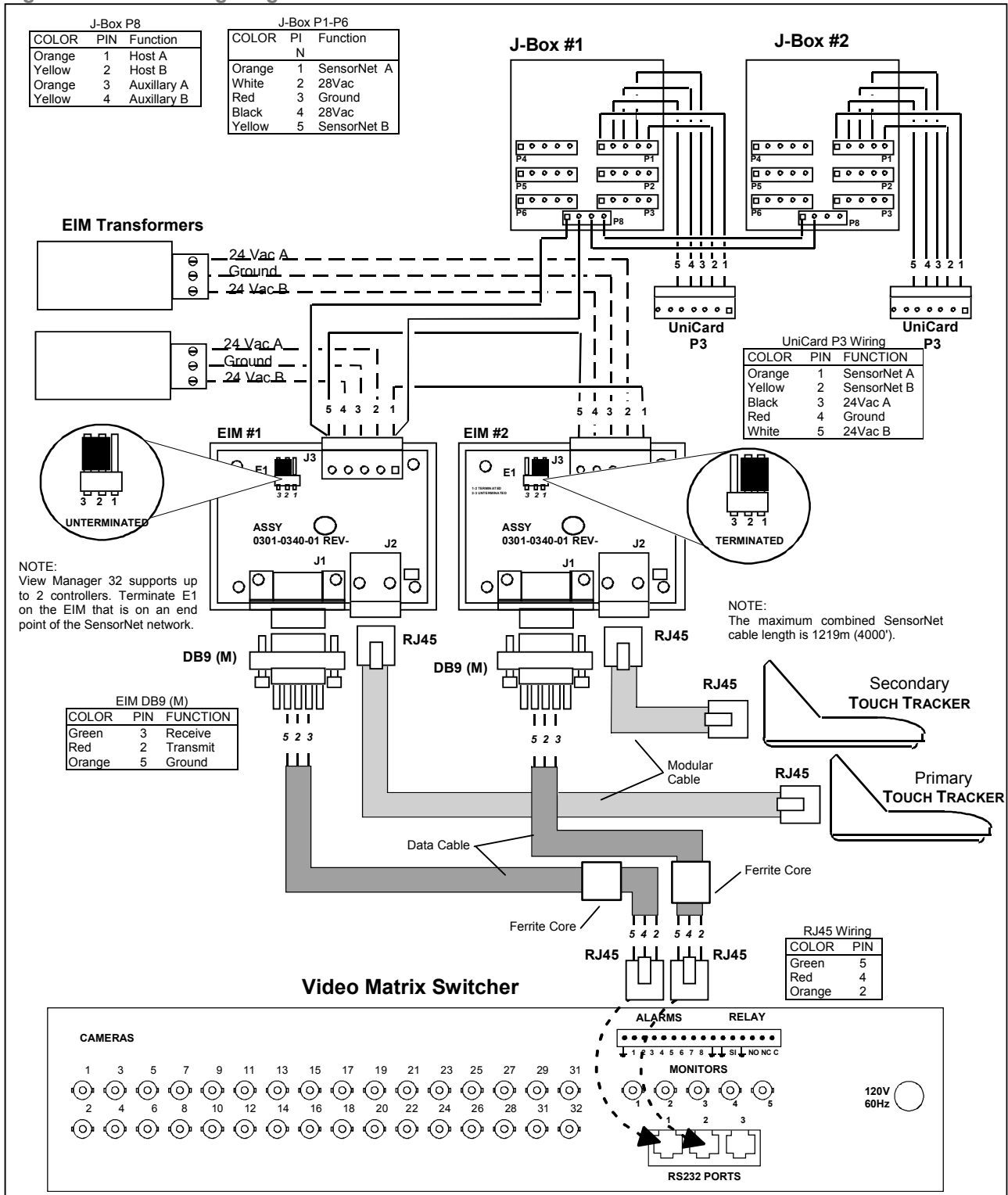

4. Connect the power transformer cable and the SensorNet data cable, and if required, the data cable to EIM #2, to the compression connector, and connect it to J3 on each EIM.
5. Wire the DB9 connector to the data cable. See the tables in Figure 1. Assemble the hood onto the DB9 connector.
6. Install the ferrite core onto the cable assembly, 2.54-3.81cm (1 in.-1.5 in.) from the RJ45 connector (see Figure 2).
7. Connect the data cable to J1 on the EIM to the RS232 port 1 (primary) or port 2 (secondary) on the rear panel of the Video Matrix Switcher.
8. Connect a modular cable to J2 on EIM and to the TOUCH TRACKER controller.
9. Plug each power transformer into a grounded, 3-wire receptacle.

NOTE: If the keypad and backlighting do not illuminate when power is applied, unplug the power transformers, check all wiring connections, and repeat step 9.
10. Press **Menu** to configure the TOUCH TRACKER controller as a primary or secondary unit.
11. Page down the screen to the Tog Primary/2nd menu option.
12. To select the Tog Primary/2nd menu option, press the zoom (top line) or focus (bottom line) button, as appropriate.
13. Press **Next** to toggle between using the TOUCH TRACKER controller as the primary unit or as the secondary unit.
14. Press **Menu** to reset the TOUCH TRACKER controller as a primary or secondary unit. The controller will reboot to the Camera Control Mode.

Figure 2. Ferrite Core Attachment

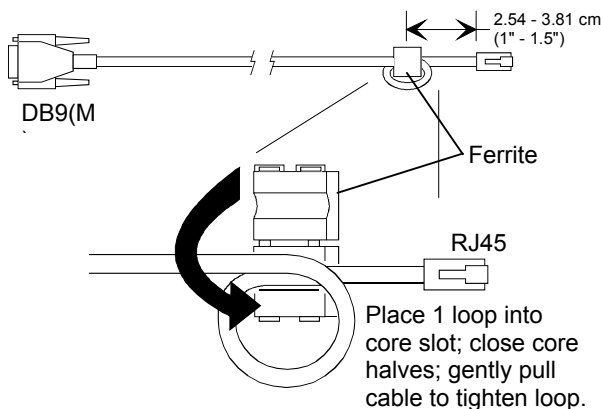

Resetting a Dome

1. Use the number buttons to select the dome to reset, then press  (the **Camera** button).
2. Press **Menu**.
3. Using the Tracker Ball, scroll down to Reset Dome.
4. Press the zoom (top line) or focus (bottom line) button to select the Reset Dome menu option.

The TOUCH TRACKER will send a request to the selected dome to reboot.

Switching Primary and Secondary Functions between Controller Units

1. Press **Menu**.
2. Using the Tracker Ball, scroll down to Tog Primary/2nd.
3. Press the zoom (top line) or focus (bottom line) button to select the Tog Primary/2nd menu option.

An asterisk (*) identifies the current setting for the TOUCH TRACKER.
4. Press **Next** to toggle between using the primary unit for SensorNet polling and alarm monitoring or as the secondary unit with limited user functionality.
5. Press **Menu** to reset the controller as a primary or secondary unit.

The controller will reboot and return to the Camera Control Mode.

Adjusting V-Phase

1. Press **Menu**.
2. Using the Tracker Ball, scroll down to Adjust V-phase.
3. Press the zoom (top line) or focus (bottom line) button to select the Adjust V-phase menu option.
4. Press **Next** or **Prev** to observe V-phase through the oscilloscope or Fluke scope.
5. Press **Menu** to exit.

Off-line domes or fixed cameras will generate a warning beep and disallow use of the V-phase utility. For additional information on adjusting V-phase, see the Service section of the View Manager 32 manual.

Reviewing System Information

1. Press **Menu**.
2. Using the Tracker Ball, scroll down to Show Sys Info.
3. Press the zoom (top line) or focus (bottom line) button to select the Show Sys Info menu option. The LCD screen displays the following message:

Primary/Secondary Indicator:

```

Primary Unit
<NEXT>      <PREV>
  
```

4. Press **Next** to step through the following messages:

Flash and EEPROM checksum values:

```

ROM Checksum
E=0A7B      F=9C82
  
```

↑ EEPROM Checksum ↑ Flash Checksum

Tracker Ball calibration values:

```

Min  00 00 00 00
Max  00 00 00 00
  
```

Flash and EEPROM part numbers (including version):

```

Product Code
F 0701-0000-0000
  
```

↑ Flash Part Number and Version

```

Product Code
E 0701-0000-0000
  
```

↑ EEPROM Part Number and Version

5. Press **Menu** to exit.

Performing SensorNet Ping Test

1. Use the number buttons to select a dome to test, then press  (the **Camera** button).
2. Press **Menu**.
3. Using the Tracker Ball, scroll down to Ping Dome/TTR.
4. Press the zoom (top line) or focus (bottom line) button to select the Ping Dome/TTR menu option and to start the ping test on the selected dome. The LCD screen displays the following message:

```

*=Device being tested
No. of pings transmitted
*Dome      Tx=0006
TTR      Bad=0002
No. of failed responses
  
```

5. Press **Next** to perform the ping test on the Secondary TOUCH TRACKER controller unit.
6. Press **Menu** to exit.

Off-line domes or fixed cameras will generate a warning beep and disallow use of the SensorNet network test.

Changing the Port Setting

1. Press **Menu**.
2. Using the Tracker Ball, scroll down to Port Settings.
3. Press the zoom (top line) or focus (bottom line) button to select the Port Settings menu option. The LCD screen displays the following message:

```

↓ *=Selected mode
*Operating Mode
Download Mode
  
```

4. Press **Next** to change the currently selected mode.
5. Press **Menu** to save the change and exit.

Remote Switcher Location

If the EIM and TOUCH TRACKERS will be located more than 4m (14 ft) but less than 15m (50 ft) from the Video Matrix Switcher, the following additional equipment will be needed:

Description	Qty	Part No.
CABLE ASSY,MDLR,14FT,8 COND,CROSS-P	1	6003-0047-01
TERMINAL, RJ45	2	2113-0019-01
ANCHOR,PLASTIC,W/O SCREW,8-10	4	2880-0083-01
SCR,TYP AB,PHP,CAD,#8X1"	4	2816-7634-44
CABLE,3COND,18AWG,4M-15M (14'-50")	1	6002-0024-01



WARNING: Shock Hazard!

Disconnect AC Power.



CAUTION: static sensitive components!

Follow proper handling procedures to prevent component failure.

Installation Procedures

1. Attach each EIM to a wall or other surface within 3m (10 ft) of its TOUCH TRACKER controller.
2. Terminate the EIM at the end of the SensorNet network.
See Figure 1 for the wiring diagram for a typical 2-controller VM32 system installation. See Figure 3 for the wiring diagram for remotely located Video Matrix Switcher. For more information on the SensorNet network, see the *SensorNet Network Guide* (PN 8000-0970-01).
3. Attach the HP0047 terminal boxes to a wall. The remote terminal box must be within 15m (50 ft) of the EIM terminal box.
4. Connect the 3-wire, 18AWG shielded cable to the terminal boxes (see Figure 3).
5. Attach the 3 spade lugs to one end of the 3-conductor cable, then attach the lugs to the EIM power transformer.
6. Connect the power transformer cable and the SensorNet data cable, and if required, the data cable to EIM #2, to the compression connector, and connect it to J3 on each EIM.
7. Wire the DB9 connector to the data cable. See the tables in Figure 3. Assemble the hood onto the DB9 connector.
8. Connect the data cable to J1 on the EIM to the HP0047 terminal box.

9. Install a ferrite core onto a modular cable assembly, 2.54-3.81cm (1 in.-1.5 in.) from an RJ45 connector (see Figure 2).
10. Connect the modular cable to the remote HP0047 terminal box and to the RS232 port 1 (primary) or port 2 (secondary) on the rear panel of the Video Matrix Switcher.
11. Connect a modular cable to J2 on EIM and to the TOUCH TRACKER controller.
12. Plug each power transformer into a grounded, 3-wire receptacle.
NOTE: If the keypad and backlighting do not illuminate when power is applied, unplug the power transformers, check all wiring connections, and repeat step 12.
13. To configure the TOUCH TRACKER controller as a primary or secondary unit, page down the screen to the Tog Primary/2nd menu option.
14. To select the Tog Primary/2nd menu option, press the zoom (top line) or focus (bottom line) button, as appropriate.
15. Press **Next** to toggle between using the TOUCH TRACKER controller as the primary unit or as the secondary unit.
16. Press **Menu** to reset the TOUCH TRACKER controller as a primary or secondary unit. The controller will reboot to the Camera Control Mode.

Figure 3. VMS Wiring Diagram—Remote Switcher Location

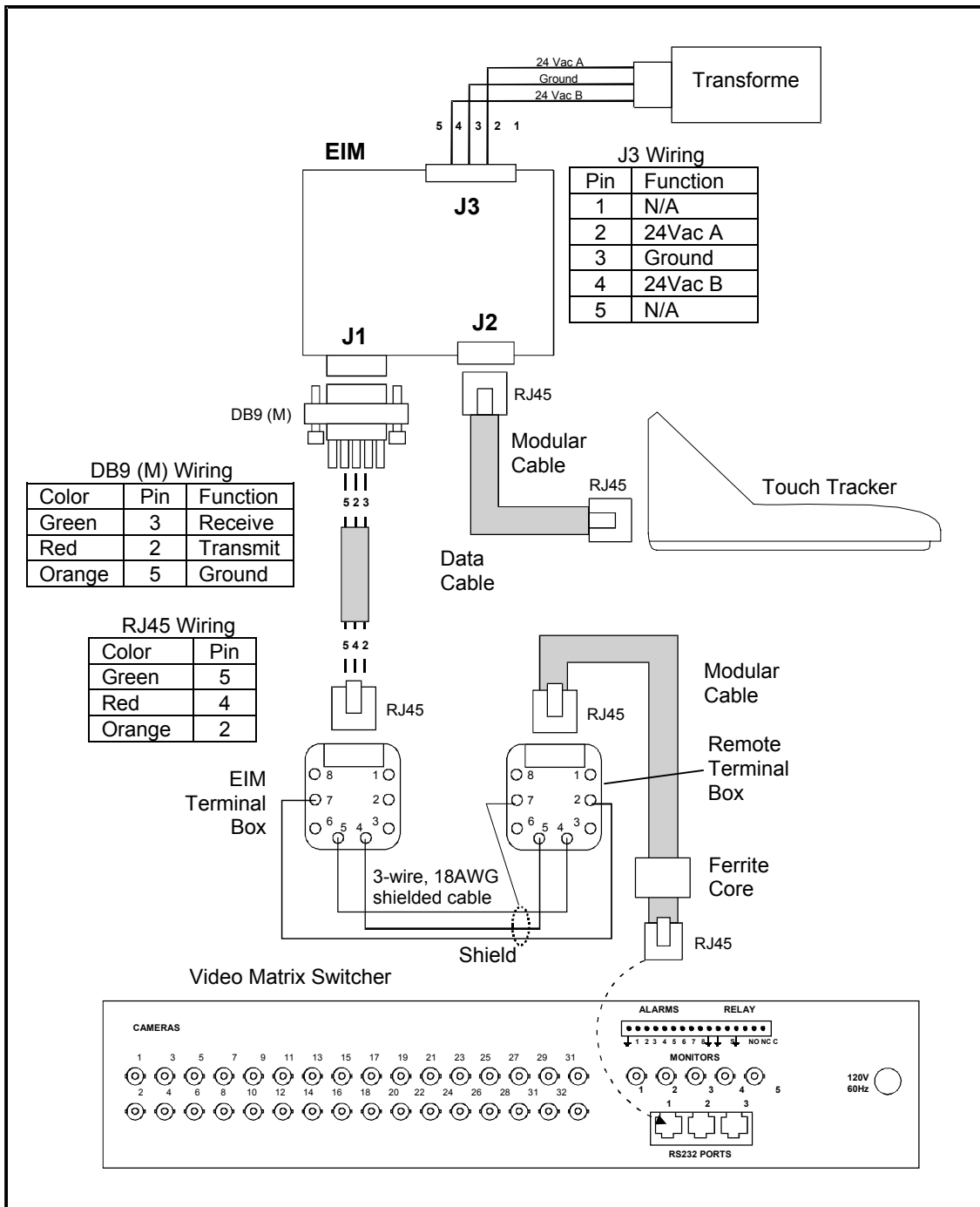

Alarm and Relay Connections

The back panel of the VM32 Video Matrix Switcher provides eight alarm contact inputs, an external frequency synchronization input, and contact terminations for an internal alarm-activated relay. You can program the Form-C internal relay to activate during alarms for control of a VCR or other alarm response device.

Figure 4. Alarm/Relay Connections

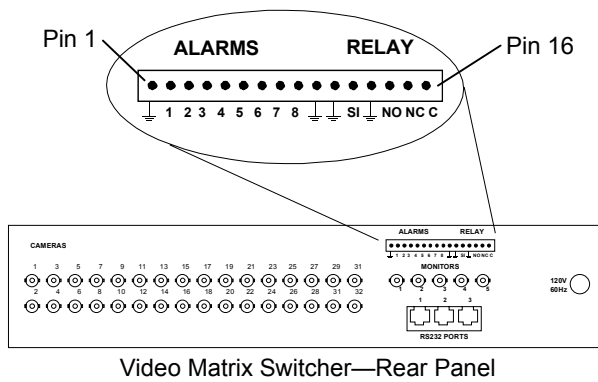

The following is a description of the alarm and relay connector pins.

Pin	Description
1	Ground
2	Alarm 1
3	Alarm 2
4	Alarm 3
5	Alarm 4
6	Alarm 5
7	Alarm 6
8	Alarm 7
9	Alarm 8
10	Ground
11	External Sync Ground
12	External Sync Input
13	Ground
14	Relay—Normally Open
15	Relay—Normally Closed
16	Relay—Common

Connections

Alarms

- Alarm contact closures must have a resistance of 500 Ohms or less.
- Connect alarm contacts to inputs 1 through 8 (pins 2 through 9).
- Connect alarm contact returns to Ground (pin 1 or 10).

External Sync

- External sync input signal must be 1-5Vrms, 50/60Hz.
- Connect external sync input to **SI** (pin 12).
- Connect external sync ground to Ground (pin 11).

Relay

- Connections for the internal relay are normally open (NO), normally closed (NC), and common (C). The relay contact ratings are 0.6A @ 120Vac or 2.0A @ 30Vdc.
- Connect an alarm-response device requiring a normally open circuit to **NO** (pin 14) and **C** (pin 16).
- Connect an alarm-response device requiring a normally closed circuit to **NC** (pin 15) and **C** (pin 16).