

## ADIOB Mounting Base

This guide explains how to:

- Attach the base with I/O board (Figure 1) to a hard or tile ceiling, or to a mounting structure, and
- How to wire the I/O board.

Figure 1. Base of camera dome

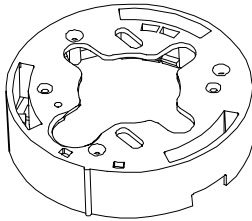

## Warnings and Cautions

Please review the following warnings and cautions before you install the mounting base. For additional warnings and cautions, see the camera dome installation guide.

### WARNINGS



#### WARNING!

ALWAYS USE:

- Proper safety equipment for the location and type of installation.
- Proper lift equipment to reach the installation.
- Safety features of the lift equipment.

BE SURE:

- Electrical power is not connected to the dome when connecting wires. Dome will move when power is applied.
- Electrical power is not connected to nearby fixtures that you might touch during installation.



#### WARNING!

DO NOT install this camera dome in hazardous areas where highly combustible or explosive products are stored or used.



#### WARNING!

**This dome runs on 24Vac.** DO NOT connect line voltage to this dome.

**North America power requirements:** In North America, this device is intended to be supplied from a Class 2 power supply. For outdoor installations, use Class 3 wiring techniques, liquid-tight conduit, or liquid-tight pipe.

This installation should be made by a qualified service person and should conform to all local codes.



#### WARNING!

**EU power requirements:** This product runs on 24Vac. In the EU, it is intended to be powered from a Limited Power Source. A limited power source is a certified source of SELV, and if inherently limited, with 8 amps maximum output current, and a maximum of 100VA available; or if not inherently limited, fused with a maximum value of 3.3 Amps, meeting section 2.11 of IEC950, and a maximum of 250VA available. The power supply can be obtained through American Dynamics or through another source where the provider can furnish the verification. This is required to assure electrical safety in the product.

**Stromanforderungen in der EU:** Dieses Produkt wird mit 24 V Wechselstrom betrieben. In der EU ist es für den Betrieb durch eine begrenzte Stromquelle vorgesehen. Eine begrenzte Stromquelle ist eine zertifizierte SELV-Quelle (Schutzkleinspannung), bei inhärenter Begrenzung mit einem maximalen Ausgangsstrom von 8 A und 100 VA maximaler Verfügbarkeit, bei nicht inhärenter Begrenzung mit einer maximalen Sicherung von 3,3 A gemäß Abschnitt 2.11 der IEC950 und 250 VA maximaler Verfügbarkeit. Das Netzteil kann über American Dynamics oder eine andere Quelle bezogen werden, wobei der Anbieter den Nachweis der Konformität bereitstellen sollte. Dies ist zur Gewährleistung der elektrischen Sicherheit des Produktes erforderlich.

## Cautions

- ❑ The maximum length of power cable allowed between the Class 2 LPS (low voltage) ac source, such as a J-box, and the dome is 250m (820').
- ❑ Do not run data and power cables adjacent to or in the same conduit as line voltage mains power.
- ❑ SensorNet 485 networks require 22 AWG unshielded cable. Do not exceed 32 devices per cable run.
- ❑ RS422 networks require 22 AWG shielded cable. Do not exceed 10 devices per cable run.
- ❑ Manchester networks require 18 AWG shielded cable. Do not exceed 3 devices per cable run.
- ❑ Always terminate the camera dome connected at the end of a cable run.
- ❑ The I/O board is electrostatic-sensitive! Use a ground strap when handling the I/O board.
- ❑ The spring finger connector on the I/O board has a dust cover. DO NOT remove this cover until you have installed the dome's base. It protects delicate spring fingers. Keep the dust cover for use should you have to ship the mounting base back to the manufacturer.
- ❑ Screw terminal connectors on the I/O board are delicate! Use a jeweler's 2.5mm (0.1") slotted screwdriver to tighten connector screws. DO NOT over tighten these screws.

---

## Installation Procedures

This section explains how to attach the base and wire the I/O board. Once done, refer to *Installation and Service Guide* 8000-2616-01 included with the housing and eyeball assembly for further instructions. Perform procedures in the following order:

1. Detach the I/O board from the base (page 3).
2. Attach the base indoors to a:
  - Hard ceiling (page 4)
  - Mounting structure (page 5).
3. Wire the I/O board (page 6).
4. Reattach the I/O board (page 8).

## Before You Begin

Please read the following to ensure a smooth and successful installation.

You must:

- Have electrical work comply with latest national electrical code, national fire code, and all applicable local codes and ordinances.
- Coordinate work with other trades to avoid interference.
- Verify existing site conditions and coordinate with the owner's representative and appropriate utilities as required.
- Obtain copies of all related plans, specifications, shop drawings and addenda to schedule and coordinate related work.
- Thoroughly review the project to ensure that all work meets or exceeds the above requirements. Bring alleged to the attention of the CCTV Project Coordinator.

You should have on hand:

- Phillips-head screwdriver
- Power drill with 1/8", 1/4", and 3/8" drill bits
- Hammer
- Socket wrench with 6-inch extension, and 5.5mm and 10mm sockets
- Jeweler's 2.5mm (0.1") slotted screwdriver (for wire connections)
- 18-14 AWG and 22-20 AWG wire strippers
- Vacuum and broom
- Install kit 0351-1520-02.

**Note:** In the following procedures, letters in brackets [ ] and in figures refer to items in kit, which includes:

a)	Base, with I/O Board	1	0100-1340-01
b)	Anchor, Toggle	2	2880-0073-01
c)	Screw, STAP, 4.2x32 PH	2	5810-4091-120
d)	Washer, Flat, M4	2	5842-0300-020
e)	Nut, Locking, M3	2	5826-0200-020

## Detaching the I/O Board

To attach the base [a], you must first remove the I/O board. To do this, push the fingers molded into the base away from the board while pushing on the I/O board with your index finger (Figure 2). Put the board in a safe place; it will be used when you attach the dome.

**CAUTION:** The spring finger connector on the I/O board has a dust cover. DO NOT remove this cover until you have installed the dome's base. It protects delicate spring fingers. Keep the dust cover for use should you have to ship the mounting base back to the manufacturer.

**CAUTION:** Use a ground strap when handling the I/O board.

Figure 2. Detaching I/O board

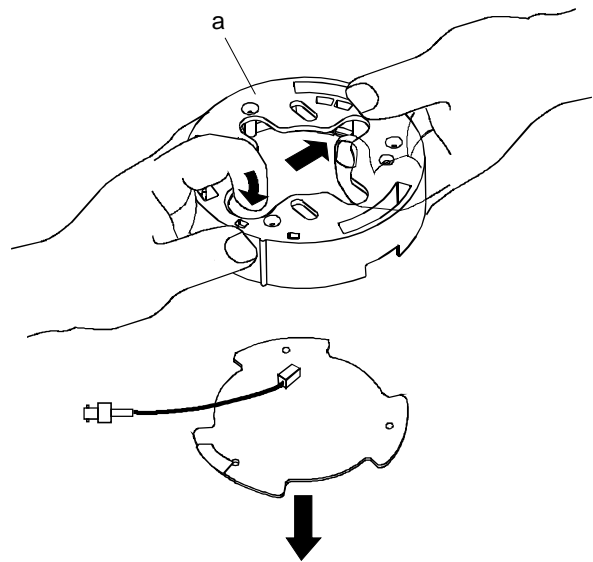

## Attaching to a Tile Ceiling

Requires RHIUTBAR T-bar kit (optional).

## Attaching to a Hard Ceiling

To attach the base to a hard ceiling, do the following (Figure 3):

1. Mark and drill holes.

Place base against ceiling and mark and drill holes for two mounting screws. If mounting to sheet rock, also mark and drill hole for cable access.

**SHEET ROCK:** Drill two 9.5mm (3/8") holes for plastic anchors. Drill one 19.5mm (3/4") hole for cable access.

**WOOD:** Drill two 3.2mm (1/8") holes for mounting screws. If wood covers cable access hole, drill one 19.5mm (3/4") hole for cable access.

2. Attach base to ceiling.

**SHEET ROCK:** Install plastic anchors [b]. Then place washers [d] onto screws [c] and insert them into anchors.

**WOOD:** Place washers [d] onto screws [c] and insert them into the wood.

3. Feed cables through access hole and go to "Wiring the I/O Board," page 6.

Figure 3. Surface mounting to sheet rock and wood beams

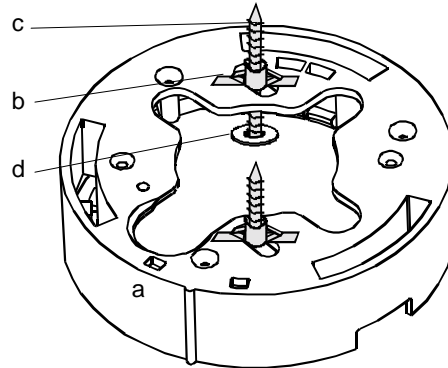

## Attaching to a Mounting Structure

To attach the base to a mounting structure:

1. Attach base to structure using two nuts supplied with structure (Figure 4).
2. Feed cables through access hole.
3. Go to "Wiring the I/O Board," page 6.

Figure 4. Attaching base to mounting structure

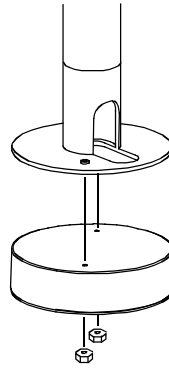

Use M3 nuts from mounting structure RHIULWM or RHIUPND

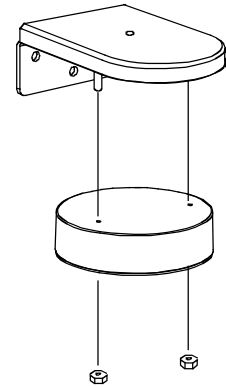

Use M3 nuts from mounting structure RHIUWM

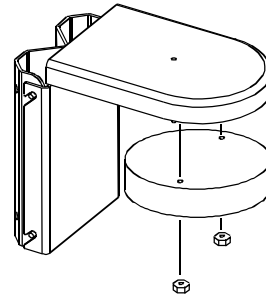

Use M3 nuts from mounting structure RHIUCM

## Wiring the I/O Board

**CAUTION:** The maximum length of cable allowed between the Class 2 LPS (low voltage) ac source, such as a J-box, and the dome is 250m (820').

This procedure explains how to connect cables to the I/O board, check cable connections, and attach the I/O board to the dome's base. Once done, attach the housing and eyeball assembly to the base (refer to instructions included with housing and eyeball assembly).



### WARNING!

Ensure that ac power and electrical signals are off during wire connections!

Referring to Figure 5:

1. Set communications jumpers.  
If communication lines do not continue, set jumper JW1 across pins 2–3 for “terminated”.  
If comm. lines continue to another dome, set jumper JW1 across pins 1–2 for “unterminated”.
2. Connect video cable.  
Connect cable to BNC connector on I/O board.
3. Connect data cable to connector P1.

**Manchester data.** Order data cable 88760 (plenum) or 8760 (non-plenum) from Belden by calling 1-800-235-3361.

Pin	Color	Designation
1-4	—	Not used.
5	Black	Manchester (+)
6	White	Manchester (-)

### RS422 data

Pin	Color	Designation
1	Orange	RS422 Data In High (+)
2	Green	RS422 Data In Low (-)
3	Yellow	RS422 Data Out High (+)
4	Brown	RS422 Data Out Low (-)
5-6	—	Not used.

Figure 5. Electrical connections

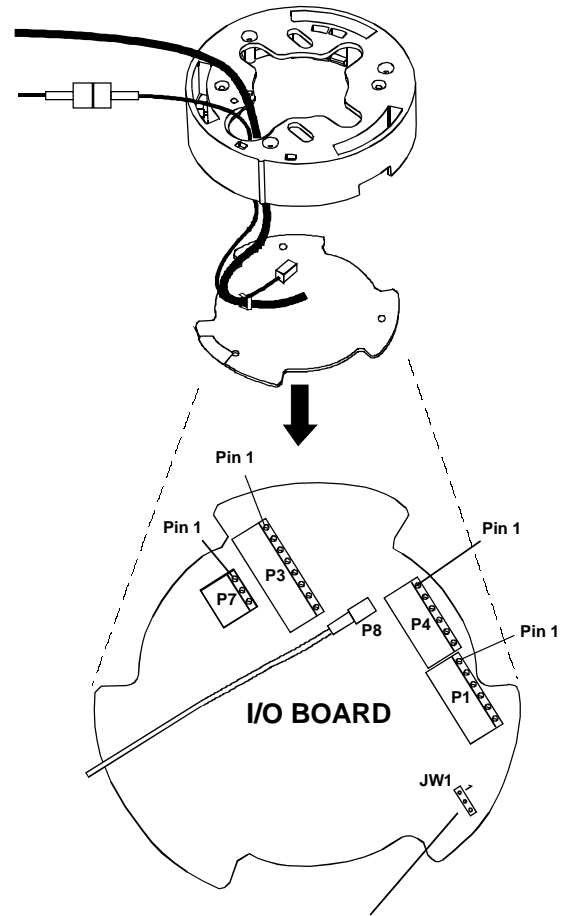

### JW1 Terminations

PINS	FUNCTION
1-2	Unterminated
2-3	Terminated

### SensorNet data

Pin	Color	Designation
1-4	—	Not used.
5	Orange	SensorNet (unshielded)
6	Yellow	SensorNet (unshielded)

- Connect alarm input cable, if used, to connector P4.

Pin	Color	Designation
1	N/A	Alarm 3 input (3.5mA sink)
2	N/A	Alarm 2 input (3.5mA sink)
3	N/A	Alarm 1 input (3.5mA sink)
4	N/A	Alarm 0 input (3.5mA sink)
5	N/A	Ground
6	N/A	Ground

- Connect alarm output cable, if used, to connector P3.

Pin	Color	Designation
1	N/A	12Vdc (100mA max.)
2	N/A	12Vdc (100mA max.)
3	N/A	Output P0 (40mA sync. max.)
4	N/A	Output P1 (40mA sync. max.)
5	N/A	Output P2 (40mA sync. max.)
6	N/A	Output P3 (40mA sync. max.)
7	N/A	Ground
8	N/A	Ground

- Connect power cable to connector P7.

Pin	Color	Designation
1	Black	24 Vac
2	Red	Ground
3	White	24 Vac

- Connect power to base.

- Test for power and data (Figure 6).

- Observe green (ac power) and yellow (comm.) LEDs. Green LED glows steadily and yellow LED glows steadily (RS422, Manchester) or blinks (SensorNet).
- For RS422, press and hold data test switch SW1 and observe nearby red and green LEDs; they indicate the following:

<i>Constant green, Blinking red</i>	RS422 line is correctly wired.
<i>Constant green, No red</i>	RS422 "Data In"– is shorted to ground.
<i>Constant red, Blinking green</i>	"Data In" + and – wires are reversed.
<i>Blinking red, Green off</i>	"Data In" + is shorted to ground.
<i>Both LEDs off</i>	"Data In" + and – wires are shorted or open.

Figure 6. I/O board and pushbutton

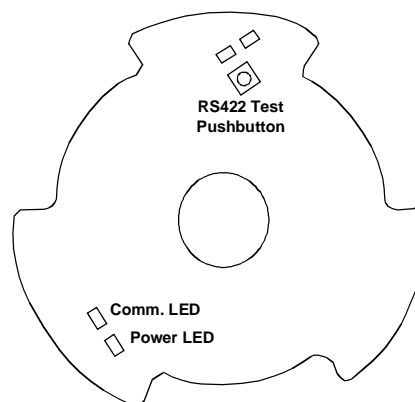

- Some I/O boards have a cable clamp. Detach and discard this clamp.

**CAUTION:** If not removed, clamp can damage the 9-pin connector in the dome's housing and eyeball assembly when you attempt to mount it to the base.

## Reattaching the I/O Board

The following procedure refers to Figure 7:

1. If wiring is OK, then pull excess cable up through access hole.
2. Reinsert I/O board.  
Aligning ground pad with finger contact above, insert board under retaining fingers. Board is keyed; it only fits into base one way. Press on board to snap in place.
3. Gently remove dust cover.  
Remove cover from 32-pin connector and inspect spring finger contacts. For reliable connections, all contacts should be at least 2mm above the surface of the connector.

**CAUTION:** Keep dust cover for use should you have to ship base and I/O board back to the manufacturer.

Figure 7. Reattaching I/O board

