

DeltaDome™ II Programmable Surveillance Camera

AD716LS and AD715LS Series

Figure 1. SpeedDome Ultra camera dome

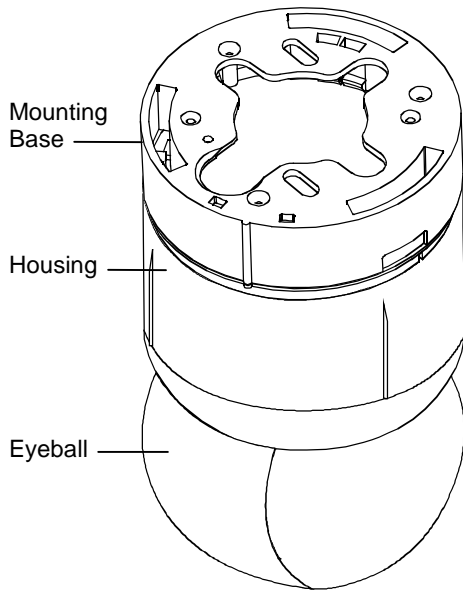

American Dynamics, DeltaDome, and the AD logo are registered trademarks of Sensormatic Electronics Corporation. Other product names (if any) mentioned herein may be trademarks or registered trademarks of other companies.

No part of this guide may be reproduced in any form without written permission from Sensormatic Electronics Corporation.

(c) Copyright 2000. All rights reserved.

MDR 6/00

Contents

About this Guide.....	1
About the Camera Dome	2
Data Cable Requirements.....	8
Install/Removal Tool for ADIOB Base.....	8
Power-Up Routine.....	9
Synchronizing Domes	9
Diagnostic LEDs.....	9
Warnings and Cautions.....	10
Indoor Installation.....	12
Using the Install/Removal Tool	20
Troubleshooting Indoor Domes.....	22
Ordering Parts.....	34
Specifications-Indoor Dome	36
Specifications-Outdoor Housing.....	37
Specifications-22X Camera.....	37
Declarations	38

About this Guide

This guide explains how to connect the camera dome to a mounting base and how to service it.

It does not explain how to:

- Determine a mounting location for the camera dome. The mounting location is determined by customer requirements; therefore, this information is provided separately.
- Attach the mounting base. There are two types of mounting bases. See information shipped with the base.
- Assemble housings and structures used with this dome. See information shipped with the housing and structure.
- Program the dome. See operator's guide shipped with the dome.

About the Camera Dome

The DeltaDome II programmable surveillance camera (Figure 1) mounts indoors or outdoors, and can communicate with the video controller over a SensorNet 485, RS422, or Manchester network. The dome consists of a mounting base, and a housing and rotating eyeball assembly.

Mounting Base

The housing and eyeball assembly connects to the base using a twist and lock action, which enables the dome to be easily moved from one location to another. The base attaches directly to a hard or tile ceiling, or indirectly to walls or ceilings using one of many optional housings and mounting structures. As shown in Figure 2, two base types are offered: an ADUPTB standard base and an ADIOB base with I/O board.

- **ADPTB Base.** With this base, video, data, and power cables are inserted through the base and attached to the top of the housing and eyeball assembly, which is then connected to the base. A lanyard connects between the base and the housing and eyeball assembly to prevent cables from being pulled during disassembly.
- **ADIOB Base.** With this base, video, data, and power cables are pre-connected to an I/O PC board. A spring-finger connector on the board makes electrical contact with the housing and eyeball assembly as it connects to the base.

Housing and Eyeball Assembly

The housing and eyeball assembly consists of the following:

- **Housing.** The housing contains the dome's power supply, pan motor, and electronics used to operate the eyeball. The housing provides one alarm input and one alarm output using the ADPTB base, or four alarm inputs and four alarm outputs using the ADIOB base.
- **Eyeball.** Gloss black and 120mm (4.75") in diameter, the eyeball contains a camera, tilt motor, and associated electronics. The eyeball enables the camera to pan and tilt to track a target moving in any direction even as it moves under the dome.

Two slot covers in the eyeball facilitate access to the camera, one of which incorporates a camouflaged lens. Remove both covers to improve ventilation when the dome is to be used outdoors.

As shown in Table 1, the housing and eyeball assembly can be ordered:

- With no base for existing indoor installations or for mounting outdoors.
- With a ADPTB standard base or ADIOB base with I/O board for new indoor installations.
- With one of four CCD cameras
 - Color NTSC
 - Black & White EIA
 - Color PAL
 - Black & White CCIR.

Each camera has 22X optical zoom with continuous auto focus and back light compensation. Electronic zoom provides selectable magnification up to 176X.

Table 1. Product codes for housing and eyeball assembly configurations

	Color NTSC	B & W EIA	Color PAL	B & W CCIR
No Base	AD716LS	AD715LS	AD716LS-1	AD715LS-1
RUPTB Base	AD716LSP	AD715LSP	AD716LSP-1	AD715LSP-1
RUIOB Base	AD716LSI	AD715LSI	AD716LSI-1	AD715LSI-1

Figure 2. Mounting base and housing and eyeball assembly

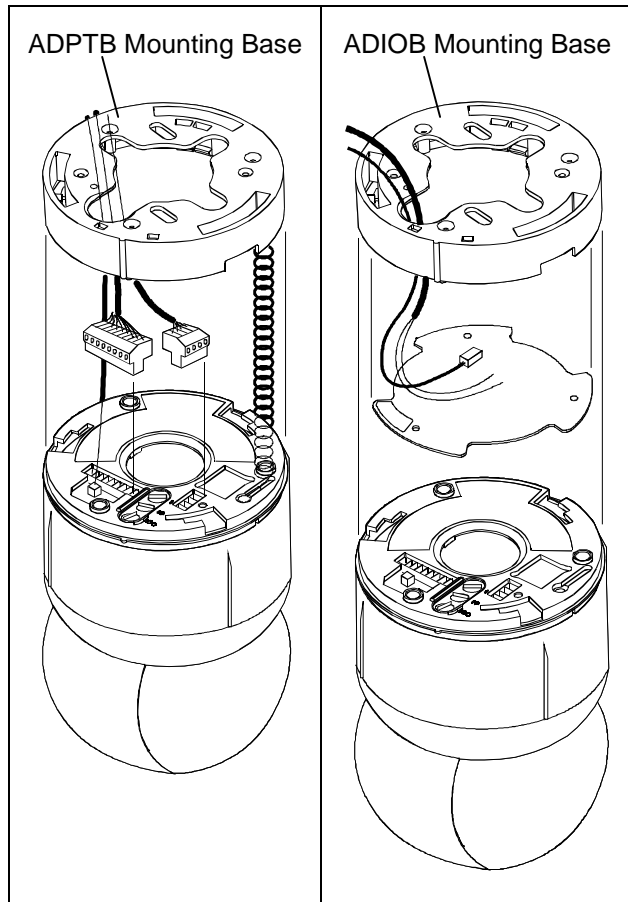

Indoor Ceiling Mounting

Using hardware shipped with the base, the dome attaches directly to indoor ceilings made of sheet rock, wood, metal, or concrete (Figure 3), or to tile ceiling T-bars where they intersect (Figure 4).

Figure 3. Surface mounting to hard ceilings

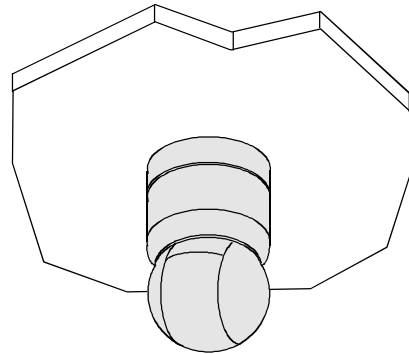
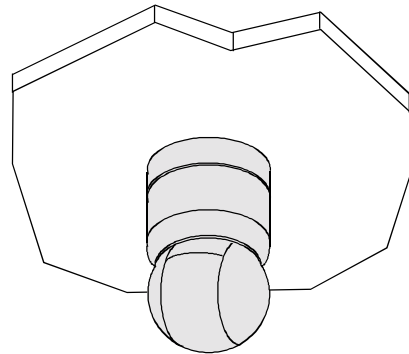

Figure 4. Surface mounting to tile ceilings



Indoor Ceiling/ Wall Mounting (Optional)

The camera dome attaches to one of the following optional indoor mounting structures (Figure 5).

Sheet Rock, Plaster or Wood Ceilings

RHIUTH	Top hat housing with trim ring This housing attaches to a ceiling or to most indoor mounting structures. A bubble and trim ring provide concealment. Optional bubbles: RUCLR (clear), RUSLV (silver), RUSMK (smoked), or RUGLD (gold). Plenum adapter RHPLA may be required to meet local fire codes.
RHIUHC	Hard ceiling bracket Enables top hat housing to be recessed in ceiling (requires top hat RHIUTH).
RHIUFB*	Fixed bracket Enables top hat housing to be recessed in ceiling (requires top hat RHIUTH).
RHIUPNDT†	Pendant mount Suspends dome from a hard ceiling.

Electrical Box in Ceiling

RHIU3X3†	3 X 3 mounting plate Attaches dome to a standard 3.5 x 3.5 duplex electrical box. CAUTION: Do not use the same electrical box used for line voltage mains.
RHIU4X4†	4 X 4 mounting plate Attaches dome to a standard 4 x 4 duplex electrical box. CAUTION: Do not use the same electrical box used for line voltage mains.

Structural I-Beams

RHIUIB†	I-beam mount Enables dome to suspend from an I-beam.
---------	---

Tile Ceilings

RHIUFB	Fixed bracket Enables top hat housing to be recessed in a 2x2 tile (requires top hat RHIUTH).
RHIUAB	Adjustable bracket Enables top hat housing to be recessed in a 2x4 tile (requires top hat RHIUTH).
RHIU2X2*	2 X 2 tile mount Enables top hat housing to be recessed in 2x2 openings (incorporates top hat housing).
RHIU2X2P*	2 X 2 tile pendant mount Enables dome to be suspended from 2x2 openings.

Wall Mounting

RHIUWM*	Wall mount Attaches dome to a flat vertical surface.
RHIUCM*	Wall mount with corner feature Attaches dome to attach to a wall, inside corner, or outside corner.
RHIULWM*†	Long .6m (24") wall mount Positions dome away from wall to enable it to see over furniture, shelving, and displays. This mounting structure attaches to the wall, inside corner, or outside corner.

* Option in white, but can be painted to match decor.

† Top hat housing/dome assembly also mounts to structure.

Figure 5. Indoor mounting structures (optional)

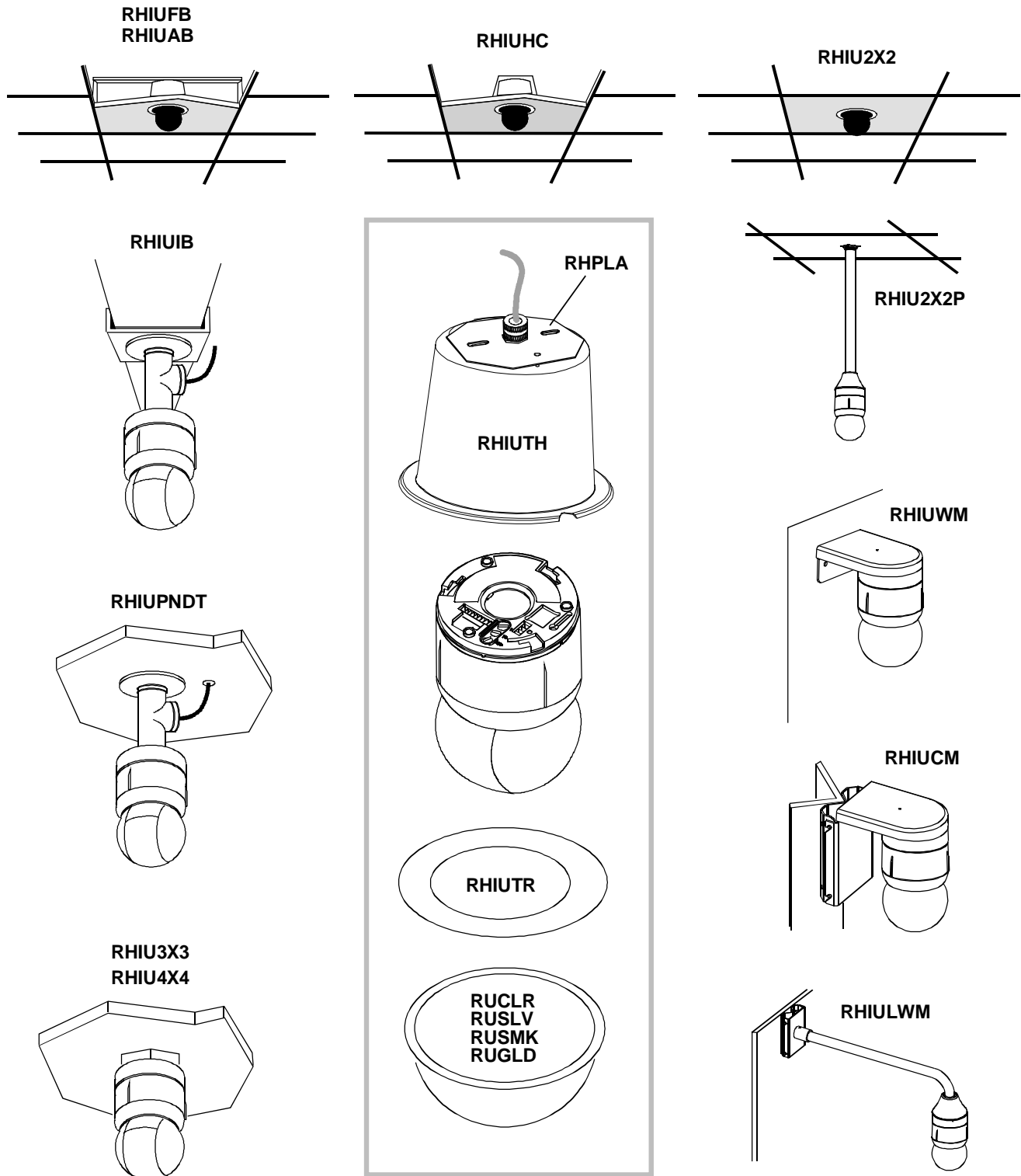

Outdoor Mounting (Optional)

Note: This document does not include outdoor installation and service instructions. For these instructions, see Installing the RHODUL Outdoor Housing, 8000-2573-04.

The camera dome attaches to outdoor walls and ceilings using an RHODUL outdoor housing (Figure 6) and one of the following optional mounting structures (Figure 8):

- RHORM Over Roof Mount
- RHOCM Ceiling Mount
- RHOPM Pole Mount
- RHOWM Wall Mount
- RH170 Corner Bracket.

The outdoor housing contains a pre-installed mounting base, a cooling fan for hot weather, a heater for cool weather and to prevent icing, and surge protection circuitry to protect against lightning strikes.

An environmental PC board is used to pre-wire cables. A round spring-finger connector on the board makes electrical contact with the housing and eyeball assembly as it connects to the base.

Note: Do not use the I/O board (designed for indoor use) in place of the environmental board.

Figure 6. ADODH outdoor housing (optional)

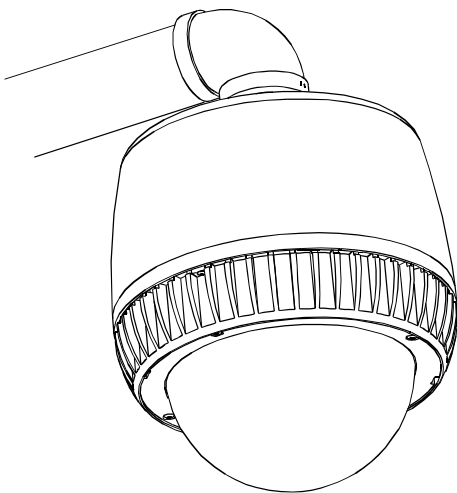

SpeedDome Housing Adapter Bracket (Optional)

An RHSDA adapter bracket (Figure 7) enables the dome to fit into SpeedDome indoor and outdoor housings. Locking pins in the bracket enable the dome to swing out for servicing or removal.

Figure 7. RHSDA adapter bracket (optional)

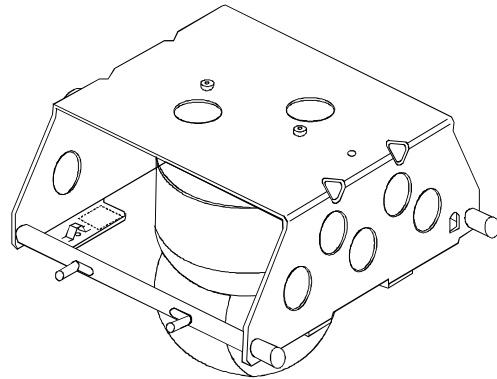
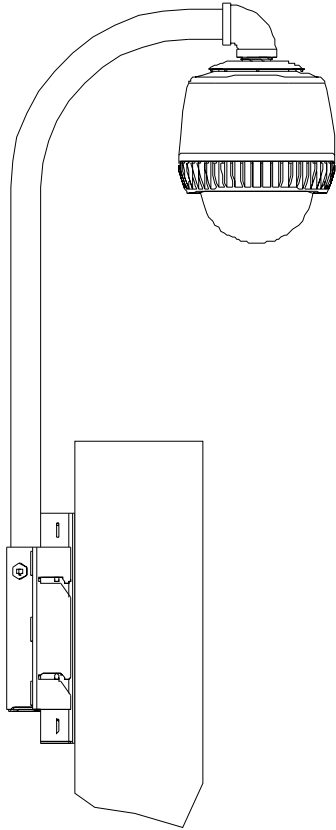
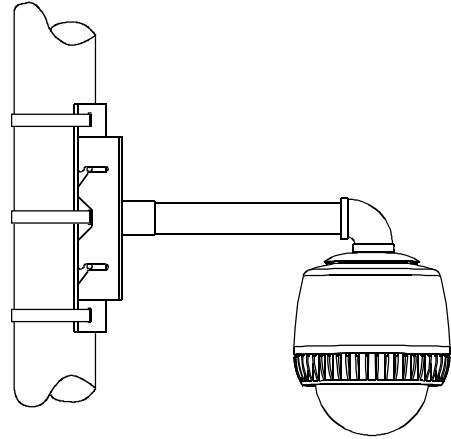

Figure 8. Outdoor mounting structures (optional)

RHORM over roof mount



RHOPM pole mount



RHOWM wall mount

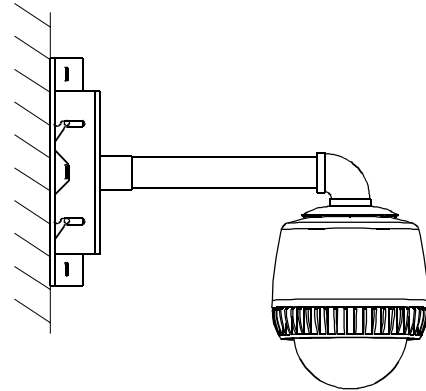

RHOCM ceiling mount

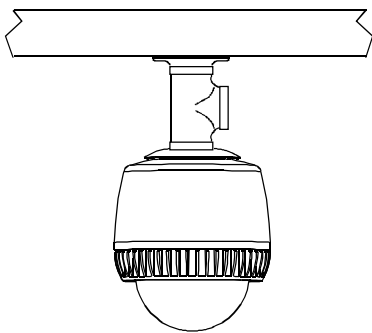

RH170 corner bracket (shown with RHOWM mount)

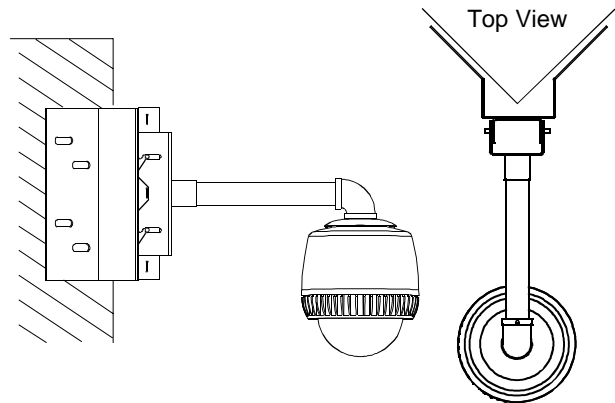

Data Cable Requirements

Table 2 shows the data cable requirements for SensorNet, RS422, and Manchester networks. For more information about communication protocols and cable networks, see Communication Protocols and Cable Networks, 8000-2573-19.

Table 2. Data cable requirements

	SensorNet	RS422	Manchester
Cable type	1 unshielded, twisted pair*	2 shielded, twisted pair*	1 shielded twisted pair**
Wire gauge	22 AWG	22 AWG	18 AWG
Con-nection	Non-polarized	Polarized	Polarized
Max. devices on line	32	10	3

* Power, data, and video cables can be ordered separately or within a composite cable that can be ordered in various lengths. Plenum-rated cables must be used in indoor ceilings used for environmental air return (called "other air space" in the National Electrical Code). Order parts through your distribution network.

Note: If you order cable from an outside source, wire colors may be different.

** Belden 88760 (plenum), or Belden 8760 cable (non-plenum) cable is recommended. Plenum-rated cables must be used in indoor ceilings used for environmental air return (called "other air space" in the National Electrical Code). Order cable directly from Belden by calling 1-800-235-3361.

Install/Removal Tool for RUIOB Base

The install/removal tool (Figure 9) enables you to connect or disconnect the housing and eyeball assembly from the RUIOB base with I/O board, and to attach/detach skirts and bubbles to a top hat housing, without the need for a ladder. The tool attaches to a telescopic pole (purchased separately). See page 20.

CAUTION: Do not use this tool to connect the dome the RUPTB base.

Figure 9. RHIRT indoor install/removal tool

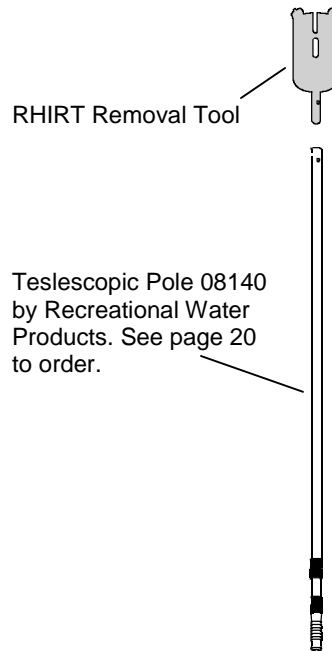

Power-Up Routine

After power is connected to the dome, the dome performs the following homing routine.

1. After a few seconds, the camera lens tilts up into the housing and eyeball assembly.
2. The lens tilts down until it looks at the floor.
3. Eyeball pans slowly.
4. Lens tilts up 90° (home position).

Once the lens is in its home position, you can then use the controller to call up the camera and control it.

Synchronizing Domes

To prevent picture rolling when switching from camera to camera, all domes can be synchronized to a 50Hz or 60Hz ac source. A V-phase adjustment at the control console enables the dome to sync to any line phase.

Diagnostic LEDs

If ADPTB standard base is used, LEDs in the housing and eyeball assembly enable you to check for power and data.

If ADIOB base with I/O board is used, LEDs on the underside of the mounting base enable you to check for power and data. If an RS422 network is used, other LEDs on the board indicate that wiring is correct, reversed, open, or grounded.

Warnings and Cautions

Please review the following warnings and cautions before you begin installation or service.

WARNINGS

WARNING!

ALWAYS USE:

- Proper safety equipment for the location and type of installation.
- Proper lift equipment to reach the installation.
- Safety features of the lift equipment.

BE SURE:

- Electrical power is not connected to the dome when connecting wires. Dome will move when power is applied.
 - Electrical power is not connected to nearby fixtures that you might touch during installation.
-
-

WARNING! DO NOT install this camera dome in hazardous areas where highly combustible or explosive products are stored or used.

WARNING! This dome runs on 24Vac. DO NOT connect line voltage to this dome.

North America power requirements: In North America, this device is intended to be supplied from a Class 2 power supply. For outdoor installations, use Class 3 wiring techniques, liquid-tight conduit, or liquid-tight pipe.

This installation should be made by a qualified service person and should conform to all local codes.

WARNING!

EU power requirements: This product runs on 24Vac. In the EU, it is intended to be powered from a Limited Power Source. A limited power source is a certified source of SELV, and if inherently limited, with 8 amps maximum output current, and a maximum of 100VA available; or if not inherently limited, fused with a maximum value of 3.3 Amps, meeting section 2.11 of IEC950, and a maximum of 250VA available. The power supply can be obtained through Sensormatic or through another source where the provider can furnish the verification. This is required to assure electrical safety in the product.

Stromanforderungen in der EU: Dieses Produkt wird mit 24 V Wechselstrom betrieben. In der EU ist es für den Betrieb durch eine begrenzte Stromquelle vorgesehen. Eine begrenzte Stromquelle ist eine zertifizierte SELV-Quelle (Schutzkleinspannung), bei inhärenter Begrenzung mit einem maximalen Ausgangsstrom von 8 A und 100 VA maximaler Verfügbarkeit, bei nicht inhärenter Begrenzung mit einer maximalen Sicherung von 3,3 A gemäß Abschnitt 2.11 der IEC950 und 250 VA maximaler Verfügbarkeit. Das Netzteil kann über Sensormatic oder eine andere Quelle bezogen werden, wobei der Anbieter den Nachweis der Konformität bereitstellen sollte. Dies ist zur Gewährleistung der elektrischen Sicherheit des Produktes erforderlich.

CAUTIONS

- ❑ For indoor domes, the maximum length of power cable allowed between the Class 2 LPS (low voltage) ac source, such as a J-box, and the dome is 250m (820').
 - ❑ Do not run data and power cables adjacent to or in the same conduit as line voltage mains power.
 - ❑ SensorNet 485 networks require 22 AWG unshielded cable. Do not exceed 32 devices per cable run.
 - ❑ RS422 networks require 22 AWG shielded cable. Do not exceed 10 devices per cable run.
 - ❑ Manchester networks require 18 AWG shielded cable. Do not exceed 3 devices per cable run.
 - ❑ Always terminate the camera dome connected at the end of a cable run.
 - ❑ When using the RUPTB standard base and wiring cables directly to the dome, ALWAYS connect the video cable to the dome before you connect the 9-pin cable (which contains power). If you connect the 9-pin cable first, you risk shorting delicate electronics near the connector.
 - ❑ I/O PC board (when used).
 - If a cable clamp is on this board, remove it, as it could damage cable connectors in the housing during assembly.
 - Use a jeweler's 2.5mm (0.1") slotted screwdriver to tighten connector screws. Do not over tighten these screws.
 - Use the dust cover when shipping the I/O board back to the manufacturer. It will protect the spring-finger connector.
 - ❑ When connecting the housing and eyeball assembly to an outdoor housing:
 - Remove both slot covers to keep the camera from overheating.
 - Keep cables entering the housing away from the heater assembly.
 - Place tubing around the BNC connectors to avoid shorting their metal surface to the outdoor housing.
 - Check heater fans. Both fans must be on to prevent overheating.
- Note:** For further information, see installation instructions shipped with the outdoor housing.
- ❑ If disassembling the dome:
 - Dome contains electrostatic-sensitive devices! Use a ground strap when handling PC boards.
 - Once disassembled, parts of housing and eyeball assembly are "extremely fragile" and may break. Proceed using extreme care!

Indoor Installation

This section explains how to connect the housing and eyeball assembly to a:

- ADPTB mounting base
- ADIOB mounting base.

Items You Will Need

You should have on hand the following tools and parts:

- Install/Removal tool to attach and detach domes and bubbles without a ladder from RUIOB mounting bases.
- Base kit:
 - ADIOB (base with I/O board), or
 - ADPTB (standard base).
- Housing and eyeball assembly, 0100-2283-XX. The -XX determines the type of camera used.
 - 25 = Color NTSC
 - 26 = Color PAL
 - 27 = Black and White EIA
 - 28 = Black and White CCIR

Other Preparations

To ensure a smooth and successful installation, you must:

- Have electrical work comply with latest national electrical code, national fire code, and all applicable local codes and ordinances.
- Coordinate work with other trades to avoid interference.
- Verify existing site conditions and coordinate with the owner's representative and appropriate utilities as required.
- Obtain copies of all related plans, specifications, shop drawings and addenda to schedule and coordinate related work.
- Thoroughly review the project to ensure that all work meets or exceeds the above requirements. Bring alleged discrepancies to the attention of the CCTV Project Coordinator.

Connecting to ADPTB Mounting Base

This procedure explains how to connect the housing and eyeball assembly to a ADPTB base.

CAUTION: The maximum length of cable allowed between the Class 2 LPS (low voltage) ac source, such as a J-box, and the dome is 250m (820').

WARNING! Ensure that ac power and electrical signals are off during wire connections!

1. Set dome address (Figure 10).

Recessed at top of housing and eyeball assembly are three rotary address switches. Address range is from 001 to 255, except for Manchester, which is 01 to 64.

Set switches from most significant bit (MSB) to least significant bit (LSB). For example: For address 166, set SW3 to 1, SW2 to 6, and SW1 to 6.

Figure 10. Setting address switches

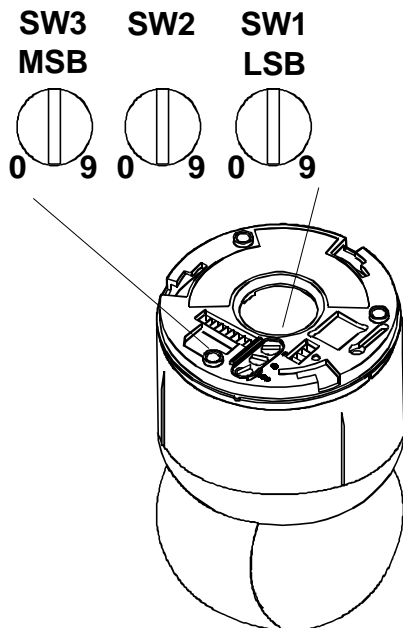

2. Attach safety lanyard to cap on housing and eyeball assembly (Figure 11). Use M3 x 6 screw supplied with lanyard.

Figure 11. Attaching safety lanyard

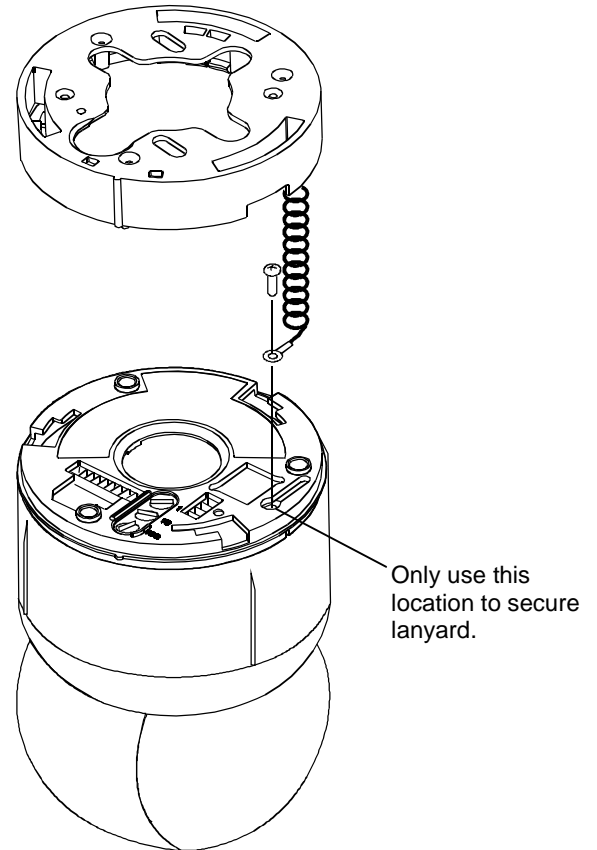

3. WITH POWER OFF, connect video cable (Figure 12).
 - a. Connect BNC of video micro coax cable 6003-0131-01 to BNC of video cable.
 - b. Feed cable through access hole in base.
 - c. Press micro coax connector into mating receptacle in top of housing and eyeball assembly. A firm snap indicates a tight connection.
4. If dome is connected at end of comm. line, set termination jumper JW1 (Figure 12).
 Jumper JW1 is pre-installed across pins 1-2 (unterminated). These pins are closest to 9-pin connector. If dome is to be connected at end of a communications line, place jumper across pins 2-3 (terminated).
 You may need a small slotted screwdriver to gently pry jumper loose. Be careful not to damage underlying PC board.

Figure 12. Video cable connection and termination jumper location

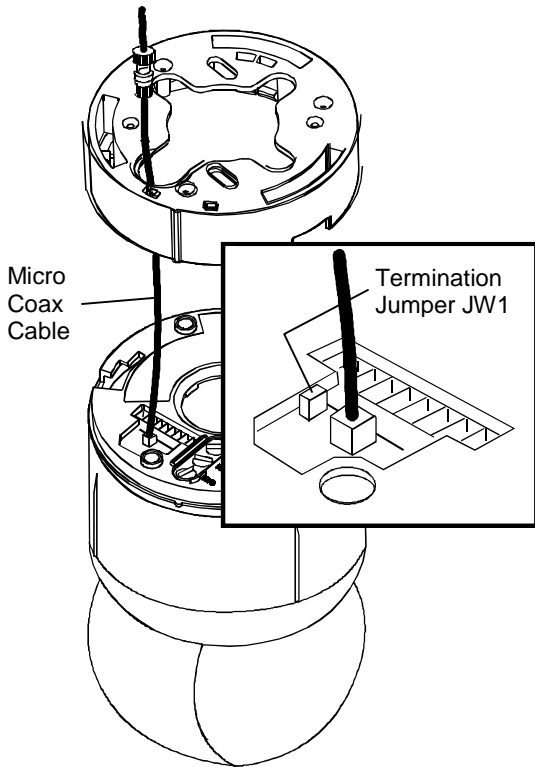

5. Connect 9-pin plug (data and power) to 9-pin receptacle (Figure 13).

CAUTION: DO NOT connect 9-pin plug unless you have performed step 3 first!

- a. Feed cables through access hole in base.
- b. Connect data and power wires to 9-pin plug (refer to charts below).
- c. Insert plug into mating receptacle in top of housing and eyeball assembly.

Manchester data and power connections (Ultra IV only). Order data cable 88760 (plenum) or 8760 (non-plenum) from Belden by calling 1-800-235-3361.

Pin	Color	Designation
1	White	Manchester (-)
2	Black	Manchester (+)
3	Black	24Vac
4	Red	Ground
5	White	24vac
6-9	—	Not used.

RS422 data and power connections

Pin	Color	Designation
1-2	—	Not used.
3	Black	24Vac
4	Red	Ground
5	White	24Vac
6	Orange	RS422 Data In High (+)
7	Green	RS422 Data In Low (-)
8	Yellow	RS422 Data Out High (+)
9	Brown	RS422 Data Out Low (-)

SensorNet data and power connections

Pin	Color	Designation
1	Orange	SensorNet (unshielded)
2	Yellow	SensorNet (unshielded)
3	Black	24Vac
4	Red	Ground
5	White	24Vac
6-9	—	Not used.

6. Connect 4-pin plug (alarm input/output) to 4-pin receptacle (Figure 13).
 - a. Feed cable through access hole in base.
 - b. Connect alarm wires to 4-pin plug (refer to chart below).
 - c. Insert plug into mating receptacle in top of housing and eyeball assembly.

Alarm connections

Pin	Color	Designation
1	—	+12Vdc
2	—	Alarm Out
3	—	Alarm In
4	—	Common

Figure 13. Cable connections (Manchester requires separate cables for data and power)

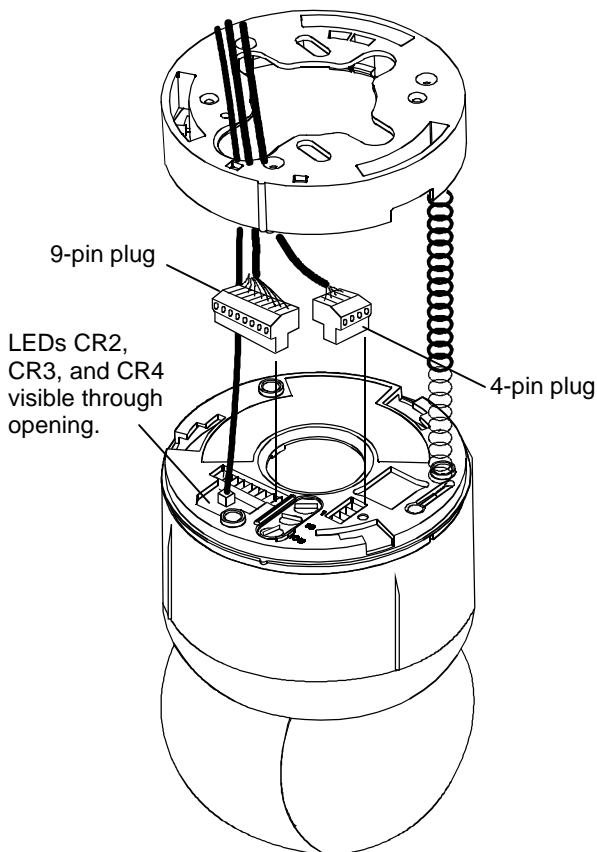

7. Check LEDs to verify that power and data are reaching dome (Figure 13).

LEDs CR2, CR3, and CR4 surround video connection and are visible through opening. LEDs light in the following order:

To test Manchester network:

- a. Yellow CR4 LED glows steadily indicating communication between controller and dome, or glows steadily, turns off, and then blinks.

Note: CR4 only blinks when both Manchester wires are connected. Green CR2 LED is not used to test Manchester.

- b. Red CR3 LED blinks slowly indicating that dome software is operating.

To test SensorNet or RS422 network:

- a. Green CR2 LED blinks indicating data present.

Yellow CR4 LED glows steadily indicating communication between controller and dome (RS422), or glows steadily, turns off, and then blinks (SensorNet).

Note: To check RS422 connections, set dome address switch SW3 to 9 and check red and green LEDs. Red should be off, green should blink. If red blinks, RS422 is wired backwards. If red and green are off, then RS422 communication is absent. When done with this test, set switch SW3 back to 0 and reset dome from controller.

- b. Red CR3 LED blinks slowly indicating that dome software is operating.

8. Connect housing and eyeball assembly to base (Figure 14).
 - a. Align dimple on cap of dome with rib on mounting base.
 - b. Mate housing and eyeball assembly to base and turn it clockwise until you hear a click.

9. Wait a few seconds for dome to begin its homing routine. Homing routine indicates that address was placed into dome memory and that dome is ready for programming.

Figure 14. Connecting housing and eyeball assembly to base (cables and lanyard not shown)

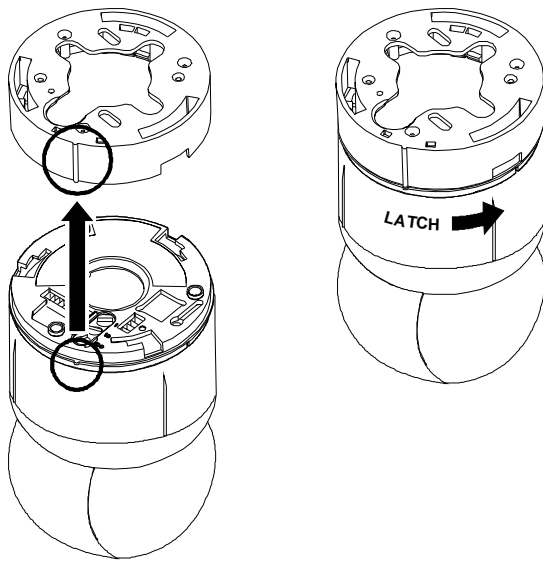

Connecting to ADIOB Mounting Base

This procedure explains how to connect the housing and eyeball assembly to an ADIOB mounting base.

CAUTION: The maximum length of cable allowed between the Class 2 LPS (low voltage) ac source, such as a J-box, and the dome is 250m (820').

WARNING! Ensure that ac power and electrical signals are off during wire connections!

Referring to Figure 15:

CAUTION: Detach and discard cable clamp if I/O board has one. If not removed, clamp can damage 9-pin connector in housing and eyeball assembly when you attempt to connect it to base.

1. Set data communications jumper JW1. If data lines continue to another dome, set JW1 across pins 1-2 (unterminated). Otherwise, set JW1 across pins 2-3 (terminated).
2. Connect video cable to BNC connector P8 on I/O board.
3. Connect Manchester, RS422, or SensorNet 485 data wires to connector P1.

Manchester data connections (Ultra IV only).

Order data cable 88760 (plenum) or 8760 (non-plenum) from Belden by calling 1-800-235-3361.

Pin	Color	Designation
1-4	—	Not used.
5	Black	Manchester (+)
6	White	Manchester (-)

RS422 data connections

Pin	Color	Designation
1	Orange	RS422 Data In High (+)
2	Green	RS422 Data In Low (-)
3	Yellow	RS422 Data Out High (+)
4	Brown	RS422 Data Out Low (-)
5-6	—	Not used.

SensorNet data connections

Pin	Color	Designation
1-4	—	Not used.
5	Orange	SensorNet (unshielded)
6	Yellow	SensorNet (unshielded)

Figure 15. Electrical connections

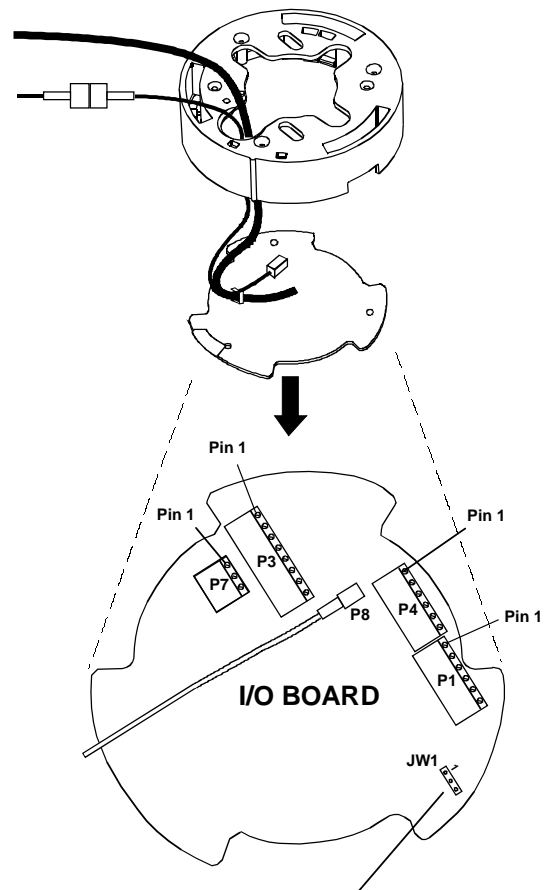

JW1 Terminations

PINS	FUNCTION
1-2	Unterminated
2-3	Terminated

- Connect alarm output cable, if used, to P3 connector.

Pin	Color	Designation
1	—	12Vdc (100mA max.)
2	—	12Vdc (100mA max.)
3	—	Output P0 (40mA sync. max.)
4	—	Output P1 (40mA sync. max.)
5	—	Output P2 (40mA sync. max.)
6	—	Output P3 (40mA sync. max.)
7	—	Ground
8	—	Ground

- Connect alarm input cable, if used, to P4 connector.

Pin	Color	Designation
1	—	Alarm 3 input (3.5mA sink)
2	—	Alarm 2 input (3.5mA sink)
3	—	Alarm 1 input (3.5mA sink)
4	—	Alarm 0 input (3.5mA sink)
5	—	Ground
6	—	Ground

- Connect power to P7 connector.

Pin	Color	Designation
1	Black	24 Vac
2	Red	Ground
3	White	24 Vac

- Reattach I/O board.
- Connect power to base.
- Check LEDs on I/O board to verify power and data are reaching dome (Figure 16).
 - Observe green (ac power) and yellow (comm.) LEDs. Green LED glows steadily and yellow LED glows steadily (RS422, Manchester) or blinks (SensorNet).
 - For RS422, press and hold data test switch SW1 and observe nearby red and green LEDs; they indicate the following:

<i>Constant green, Blinking red</i>	RS422 line correctly wired.
<i>Constant green, No red</i>	RS422 "Data In -" shorted to ground.
<i>Constant red, Blinking green</i>	"Data In +/-" wires reversed.
<i>Blinking red, Green off</i>	"Data In +" shorted to ground.
<i>Both LEDs off</i>	"Data In +/-" wires shorted or open.

Figure 16. Test switch/LEDs on I/O board

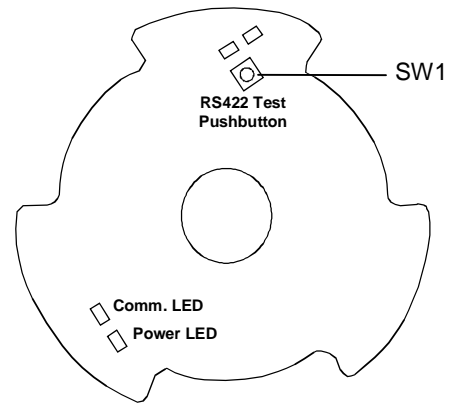

10. Set dome address (Figure 17).

Recessed at top of housing and eyeball assembly are three rotary address switches. Address range is from 001 to 255, except for Manchester, which is 01 to 64.

Set switches from most significant bit (MSB) to least significant bit (LSB). For example: For address 166, set SW3 to 1, SW2 to 6, and SW1 to 6.

Figure 17. Setting address switches

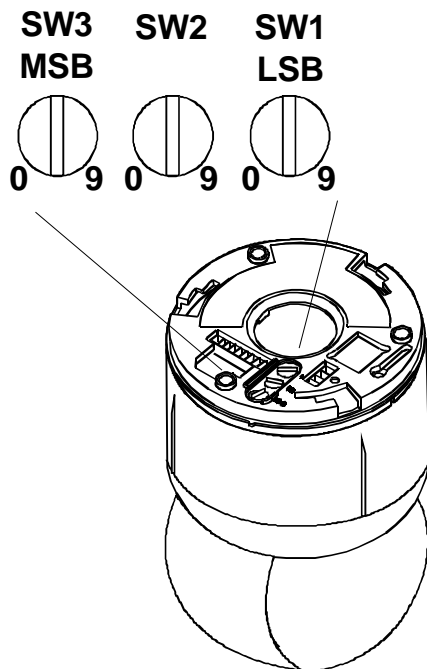

11. Connect housing and eyeball assembly to base (Figure 18).

- Align dimple on cap of dome with rib on mounting base.
- Mate housing and eyeball assembly to base and turn it clockwise until you hear a click.

12. Wait a few seconds for dome to begin its homing routine. Homing routine indicates that address was placed into dome memory and that dome is ready for programming.

Figure 18. Connecting housing and eyeball assembly to base

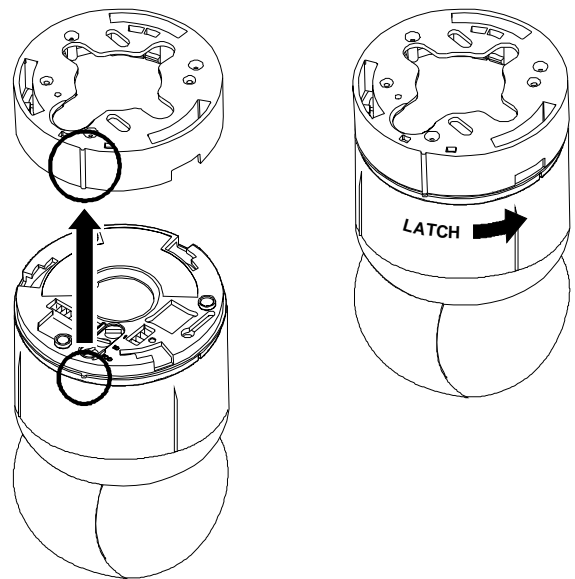

Using the Install/Removal Tool

CAUTION: Do not use this tool to connect the dome the ADPTB base.

Used only when the dome is connected to a base having an I/O board, the RHIRT install/removal tool eliminates the need for a ladder during routine service. The tool can be used to:

- Detach skirt or bubble from housing, if used. Skirt or bubble remain attached to the housing during service.
- Connect/Disconnect dome from ADIOB base.
- Reattach skirt or bubble.

Telescopic Pole Required to Use Tool

The tool attaches to a telescopic pole similar to the type used to clean swimming pools. The pole should be 5 feet, 5 inches to 15 feet, 5 inches long and have a 1.170 inch inside diameter to accept the 1.125 inch diameter stem of the tool. If this pole cannot be obtained locally, contact the following manufacturer:

Recreational Water Products
627 E. College Ave.
Decatur, GA 33030

Ask for product code 08140
UPC: 0-14746-58140-2

Procedure

Referring to Figure 19, maneuver the stem of the tool into the top of the pole until it snaps in place.

TO ATTACH SKIRT OR BUBBLE:

Use tool to push up on bubble and to secure it in place. Magnets secure the bubble. Lower pole.

TO DETACH SKIRT OR BUBBLE:

Lifting pole up at an angle, use one of the hooks on tool to catch one of the notches at side of dome and pull down. T-lanyard will prevent skirt or bubble from falling.

TO CONNECT DOME:

1. Insert dome "eyeball down" into tool's receptacle. Fins on dome mate with slots in tool. Use fins to properly align dimple at top of dome with label on tool.
2. Align label on tool with logo on I/O board in base. Push dome up into place.
3. Turn dome clockwise until it clicks.
4. If power is applied, dome should begin its "homing" routine.
5. Lower pole.

TO DISCONNECT DOME:

4. Raise pole and insert dome "eyeball down" into tool's receptacle.
5. Fins on dome mate with slots in tool.
6. Turn dome counterclockwise until it unlocks.
7. Lower pole "vertically" to prevent camera dome from falling out.

CAUTION: Turning pole horizontally as it is lowered can cause camera dome to fall out of tool and possibly break on floor.

8. Remove dome for service.

Figure 19. How to use the install/removal tool

Skirt or Bubble Attachment/Detachment

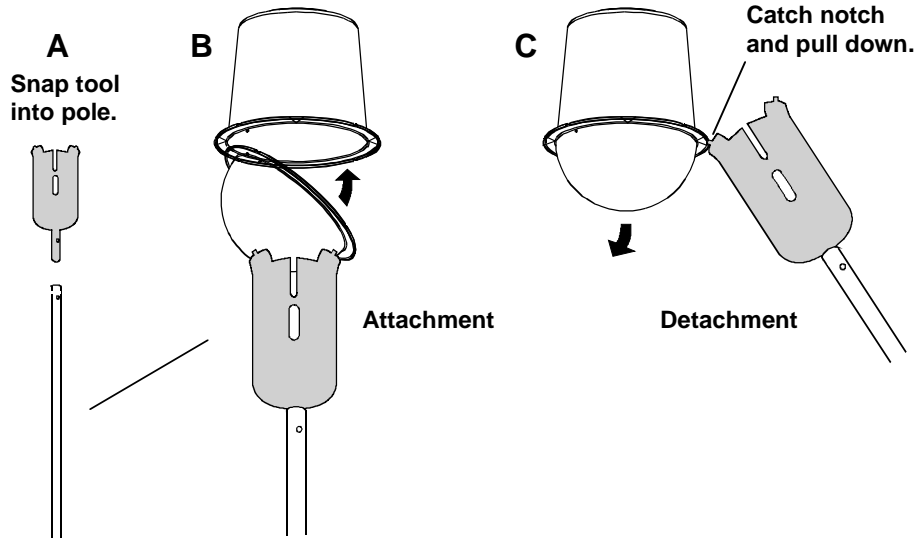

Dome Connection (reverse steps to disconnect)

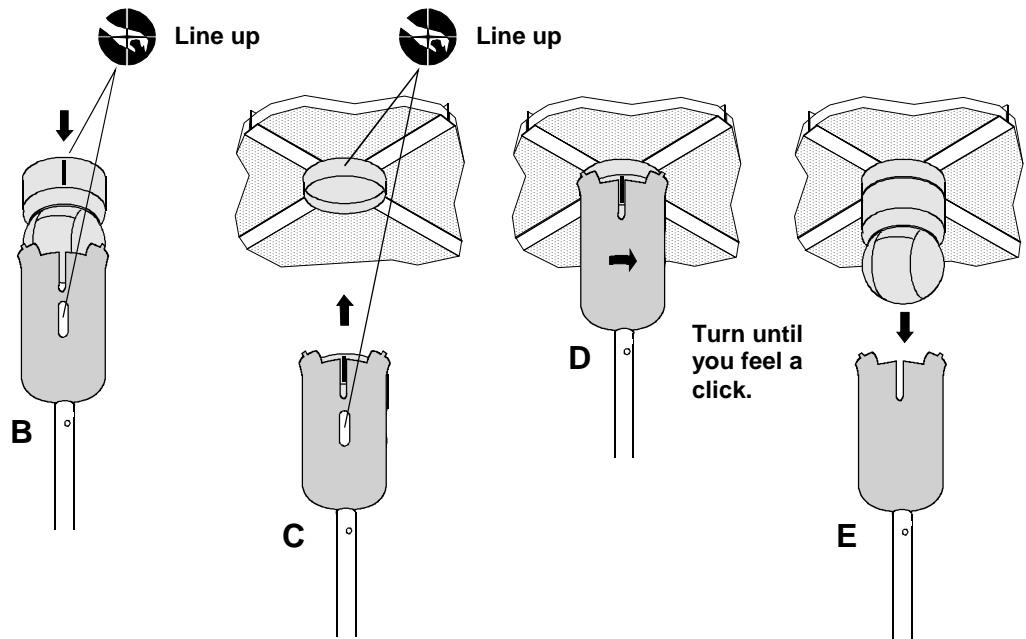

Do not use this tool to connect the ADPTB base!

Troubleshooting Indoor Domes

CAUTION: This troubleshooting section is for indoor camera domes only! To troubleshoot outdoor domes, see installation and service manual shipped with the outdoor housing.

This chapter contains information on:

- Routine troubleshooting
- Detailed troubleshooting
- Disassembling the dome.

IMPORTANT!

1. Try routine troubleshooting first! Use this procedure to isolate the problem without disassembling the housing and eyeball assembly (ADIOB base is field repairable).

CAUTION: DO NOT troubleshoot if the dome functions but does not pan or tilt (see step 2).

2. If you cannot isolate the problem, or the dome functions but does not pan or tilt, ship the dome to the National Service Center (NSC).

The manufacturer suggests that you ship the entire dome (with base, if it contains an I/O board) to the NSC. For repair authorization, call:

1-800-543-9740 (CEs)

1-800-442-2225 (Dealers)

1-800-241-6678 (End Users).

3. If you have no choice but to repair the housing and eyeball assembly. Follow the detailed troubleshooting procedure, but use extreme care.

CAUTION: Once disassembled, parts of the housing and eyeball assembly are "extremely fragile" and may break. Proceed using extreme care!

Items You Will Need

You should have on hand the following items:

- ❑ Phillips-head screwdriver
- ❑ Small slotted screwdriver
- ❑ 2.5mm (0.1") slotted screwdriver (for wire connections). Wider blade widths can damage connectors.
- ❑ Socket wrench with 5" extension and 5.5mm, 6mm, 8mm, and 10mm sockets
- ❑ 14-18 AWG and 20-22 AWG wire strippers
- ❑ Install/Removal tool to connect/disconnect dome to indoor bases with I/O boards, and to attach/detach skirts and bubbles-without a ladder.

Routine Troubleshooting

Use this procedure if:

- Dome does not respond to commands
- Dome does not produce video
- Quality of the video is poor
- Dome has no lens control.

CAUTION:

- DO NOT use this procedure if the dome functions but does not pan or tilt (see page 22).
- If an I/O board is used, use a ground strap when handling the board.
- When shipping a base having an I/O board to the manufacturer, place the dust cover over the spring finger connector to protect it.
- DO NOT overtighten connector screws on the I/O board; they are delicate. Use a 2.5mm (0.1") slotted screwdriver. Wider blade widths can damage connectors.

Procedure

Follow steps until the problem is corrected.

1. Check video on monitor (a, b, or c).
 - a. No video? Go to step 2.
 - b. Contrast or color off?
YES Ship entire dome (base included, if it contains an I/O board) back to the NSC. Place dust cover over spring finger connector on I/O board.
NO Go to step 2.
 - c. Video rolls when switching between monitors?
YES Use video controller or switcher to synchronize video vertical sync phases of all domes to ac line. For specific instructions, see installation and service manual for controller or switcher.
NO Go to step 2.
2. Check ac power and video connections at J-box. Are 24Vac and/or video signal absent?
YES Correct problem at J-box.
NO Go to step 3.
3. Detach dome from base and examine address switches. Are they set correctly?
YES If dome still doesn't respond, ship entire dome (base included, if it contains an I/O board) to the NSC. If you must repair the dome, see "Detailed Troubleshooting", next.
NO Set correct address and reattach housing and eyeball assembly.

Steps 4-9 are only for bases with I/O boards!

If the mounting base DOES NOT contain an I/O board, stop here and ship the housing and eyeball assembly to the NSC. See "IMPORTANT!" on page 22 for phone numbers.

4. Isolate problem to housing and eyeball assembly or base by attaching dome to another base with I/O board. Does dome display video or respond to commands?
 - YES Problem is likely cable connections or I/O board if used. Go to step 5.
 - NO Ship dome and base to NSC. Place dust cover over spring finger connector on I/O board.
5. Verify coaxial video cable is securely connected to coax of I/O board (Figure 20). Is cable disconnected?
 - YES Connect cable.
 - NO Go to step 6.

Figure 20. I/O board connector and jumper locations

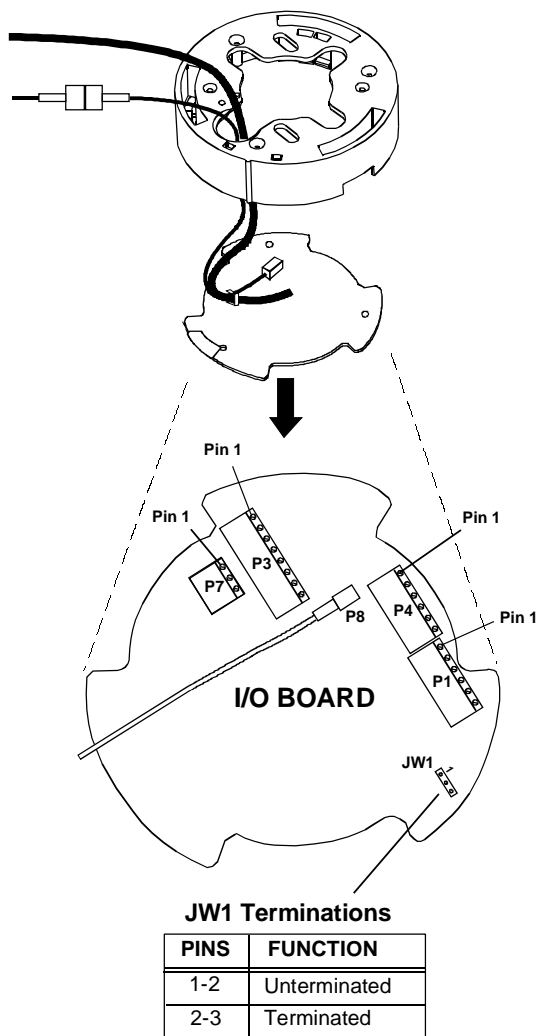

6. Observe green power LED on I/O board (Figure 21). Is green LED off or not on steady?
 - YES Verify 24Vac cable is properly attached. If O.K., replace I/O board or ship entire dome to the NSC.
 - NO Go to step 7.

P7 Connector (AC in)

Pin	Color	Designation
1	Black	24 Vac
2	Red	Ground
3	White	24 Vac

7. Observe yellow communication LED on I/O board (Figure 21). Is yellow LED flashing?
 - YES Go to step 8.
 - NO Verify cable is properly attached by referring to table in step 10, page 18. If OK, replace I/O board or ship dome and base to NSC.

Figure 21. I/O board switch and LED locations

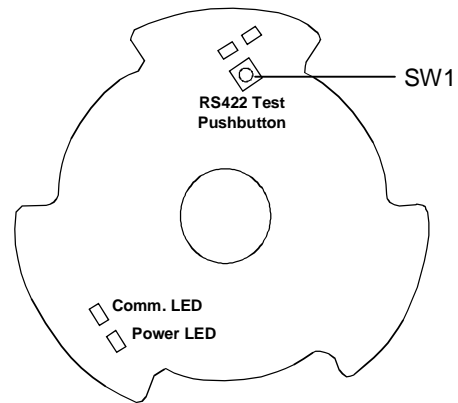

P1 connector (Manchester data)

Pin	Color	Designation
1-4		Not used.
5	Black	Manchester (+)
6	White	Manchester (-)

P1 connector (RS422 data)

Pin	Color	Designation
1	Orange	RS422 Data In High (+)
2	Green	RS422 Data In Low (-)
3	Yellow	RS422 Data Out High (+)
4	Brown	S422 Data Out Low (-)
5-6	—	Not used.

P1 connector (SensorNet 485 data)

Pin	Color	Designation
1-4	—	Not used.
5	Orange	SensorNet 485
6	Yellow	SensorNet 485

8. If using RS422 network and an I/O board is used, check comm. line connections by pressing and holding data test switch SW1 (Figure 21) and observing nearby red and green LEDs. These LEDs indicate the following:

<i>Constant green, Blinking red</i>	Comm. line correctly wired.
<i>Constant green, No red</i>	"Data In -" shorted to ground.
<i>Constant red, Blinking green</i>	"Data In +/-" wires reversed.
<i>Blinking red, Green off</i>	"Data In +" shorted to ground.
<i>Both LEDs off</i>	"Data In +/-" wires shorted or open.

9. Check spring finger connector on I/O board by connecting housing and eyeball assembly to original base to verify contact between spring fingers and CPU board (under cap). Does dome produce video and respond to commands?

YES Spring fingers may not have seated properly. Reconnect housing and eyeball assembly.

NO Replace I/O board.

If routine troubleshooting did not solve the problem, the manufacturer strongly recommends you ship the entire dome (including base, if an I/O board is used) to the National Service Center (NSC) for service. See page 22 for phone numbers.

If you must perform detailed troubleshooting, use extreme care when disassembling parts! See "Detailed Troubleshooting," next.

Detailed Troubleshooting

Use this procedure to determine if the problem is a simple cable connection or a major component.

To perform this procedure, you must open the housing and eyeball assembly. Refer to "Disassembling the Dome" on page 27.

CAUTION:

- DO NOT use this procedure if the dome functions but does not pan or tilt (see page 22).
- If routine troubleshooting did not solve the problem, the manufacturer strongly recommends you ship the entire dome (including base, if an I/O board is used) to the National Service Center (NSC) for service. If you must perform detailed troubleshooting, use extreme care when disassembling parts!
- When shipping a base with I/O board back to the NSC, place the dust cover over the spring fingers to protect them.
- Delicate connector screws on I/O board. DO NOT over tighten them! Use a 2.5mm (0.1") slotted screwdriver. Wider blade widths can damage connectors.
- Dome contains electrostatic-sensitive PC boards. Use a ground strap when handling boards.

Procedure

1. Match symptom to one of the following criteria:
 - Dome functions but does not pan
 - Dome functions but does not tilt
 - Dome does not "home" or respond to commands even when attached to another dome's base and its address switches are set correctly (dead dome).
2. Choose a, b, or c to determine if problem is a cable connection or major component.
 - a. Dome functions but does not pan.

On CPU board, is pan motor ribbon cable attached to connector P4 and is metal side of its fingers towards contacts of connector?

YES Replace CPU board. If this doesn't work, replace pan motor.

NO Connect cable(s).
 - b. Dome functions but does not tilt.

On camera/lens board, is tilt motor cable attached to connector J3? Is slip ring cable attached to connector J2?

YES Replace camera/lens board. If this doesn't work, replace tilt motor.

NO Connect cable(s).
 - c. Dome does not "home" or respond to commands (dead dome).

On CPU board, is power supply cable attached to connector P3? Is slip ring cable attached to connector P2?

YES Replace CPU board. If this doesn't work, replace power supply board.

NO Connect cable(s).

Disassembling the Dome

This section explains how to remove the following parts from the camera dome.

- CPU board, page 27
- Power supply, page 28
- Pan motor, page 28
- Slot covers, page 29
- Camera, page 29
- Eyeball, page 30
- Camera/Lens board, page 30
- Tilt motor, page 31.

CAUTION: Once disassembled, parts of dome housing and eyeball assembly are "extremely fragile" and may break. Proceed using extreme care!

This section also explains how to update and reprogram dome software (Page 33).

To order parts, see page 34.

Tools Required

- Phillips-head screwdriver.
- Small slotted screwdriver.

Removing the CPU Board

Referring to Figure 22.

1. Remove cap.

Remove three Phillips-head screws holding cap, then "gently" lift cap to one side.

2. Detach connectors.

On CPU board, detach 8-pin power supply cable from connector P1, pan motor cable from connector P8, and 14-pin slip ring cable from connector P2.

3. Remove CPU board.

Push your finger through large finger connector hole in cap to pop out CPU board.

CAUTION: Electrostatic-sensitive device. Use a ground strap when handling CPU board.

4. Reverse steps to reassemble.

CAUTION: Do not to pinch wires! When inserting CPU board into housing, avoid pinching power supply cable wires against standoffs.

Figure 22. Removing the CPU board

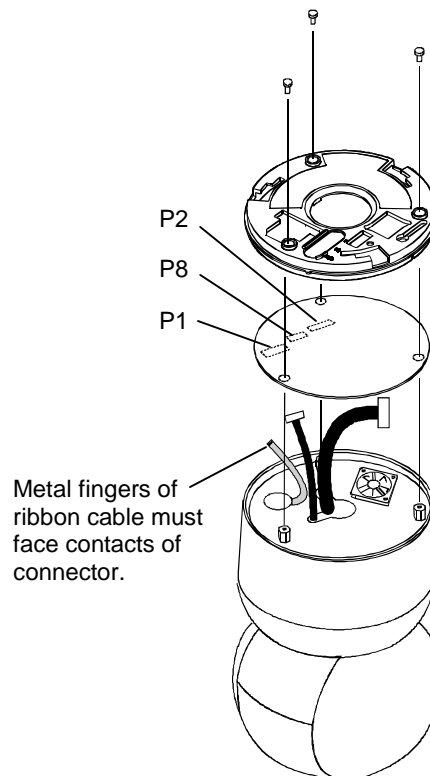

Removing the P/S Board

Referring to Figure 23.

1. Perform procedure "Removing the CPU Board" (this page).
2. Remove metal shield.
Remove three standoffs holding metal shield, gently remove power supply cable grommet from shield, then "gently" lift shield out of housing.
CAUTION: Do not pull delicate cables attached to power supply board.
3. Detach fan motor cable.
Cable connects to connector CN3 on power supply board.
4. Remove power supply board.
Remove three standoffs, then remove power supply board from housing.
CAUTION: Electrostatic-sensitive device. Use a ground strap when handling power supply board.
5. Reverse steps to reassemble.

Figure 23. Removing the P/S board

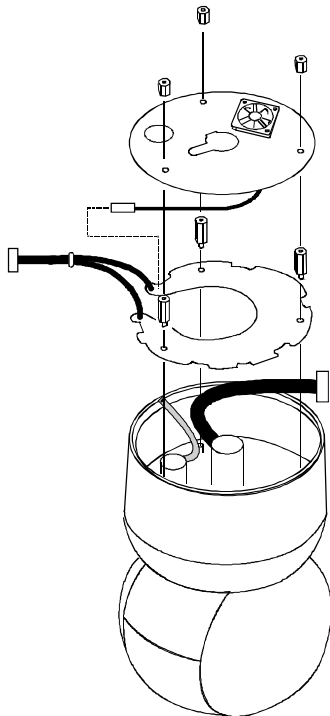

Removing the Pan Motor

Referring to Figure 24.

1. Perform procedure "Removing the CPU Board" (page 27).
2. Perform procedure "Removing the P/S Board" (page 28).
3. Remove pan motor.
Lift motor housing up as shown (1) to disengage motor from pan gear. Then pull motor bracket towards outside of housing (2) to remove.
4. Reverse steps to reassemble.
CAUTION: When putting in a new motor, be careful to properly mesh motor and pan gears! Failure to do so can destroy both motor and pan gear. Verify pan gear turns freely!

Figure 24. Removing the pan motor

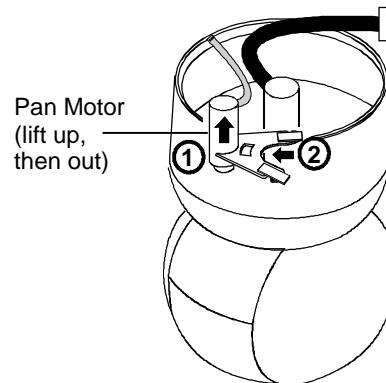

Removing the Slot Covers

1. Gently swivel eyeball to totally expose one of two slot covers (Figure 25).
- CAUTION:** Swiveling fast can damage gears.
2. Insert small, thin-bladed screwdriver into space between cover and eyeball.
 3. Gently pry off slot cover.
 4. Gently swivel eyeball to totally expose remaining slot cover. With other cover removed, this cover can be easily removed.

Figure 25. Removing slot covers

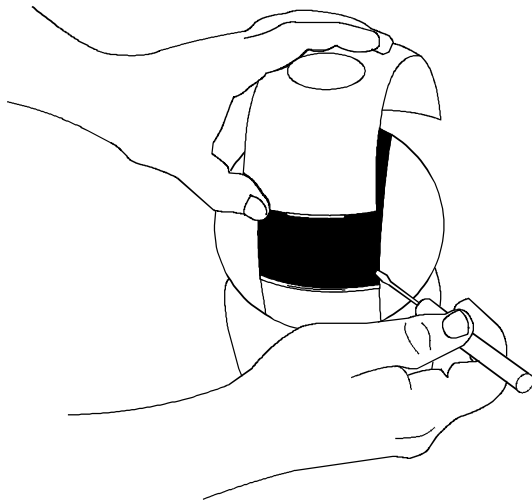

Removing the Camera

1. Perform procedure "Removing the Slot Covers" (page 29).
2. Remove ribbon cable from camera (Figure 22).
Swivel camera yoke to expose camera connector. Then, using a small slotted screwdriver, 1) gently pry camera connector loose from camera, and 2) pull it down through cable tie wrap.

Figure 26. Removing the ribbon cable

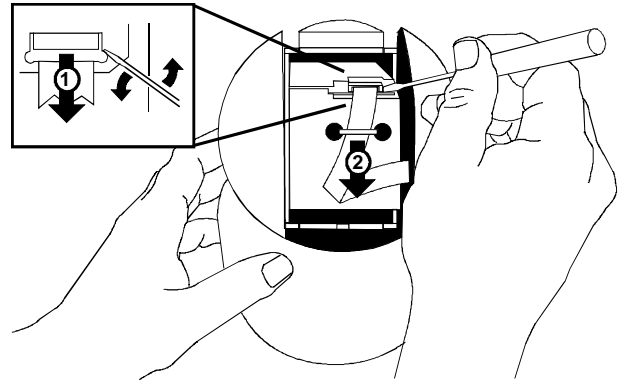

3. Remove camera (Figure 27).
1) Loosen the screw holding the camera tripod mount, then 2) carefully lift the camera out.

Figure 27. Removing the camera

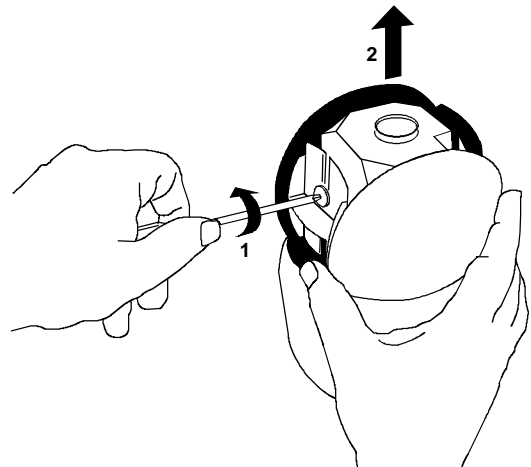

Reverse steps to reassemble. Ensure ribbon cable pins are inserted "face down".

Detaching the Eyeball

1. Perform procedure "Removing the Slot Covers" (page 29).
2. Perform procedure "Removing the Camera" (this page).
3. Detach eyeball from housing (Figure 28).
 - a. Turn yoke to access tabs. One tab is more accessible than the other. Use your finger to press this tab while, simultaneously, using a small slotted screwdriver to press the other.
 - b. While pressing tabs, push up on eyeball to detach it.

Figure 28. Loosening the eyeball

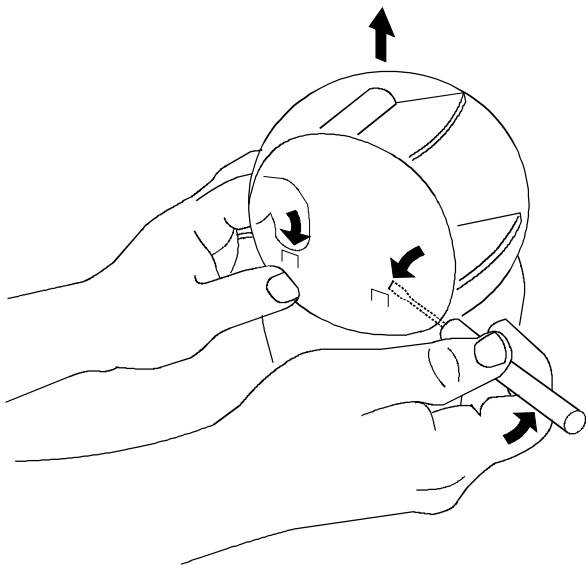

4. Detach slip ring connector (Figure 29).

Figure 29. Detaching the eyeball

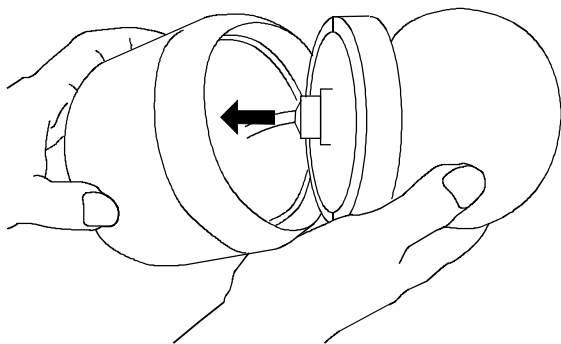

Removing the Camera/Lens Board

1. Perform procedure "Removing the Slot Covers" (page 29).
2. Perform procedure "Removing the Camera" (page 29).
3. Perform procedure "Detaching the Eyeball" (page 30).
4. Separate yoke brackets (Figure 30).

Figure 30. Separating the yoke brackets

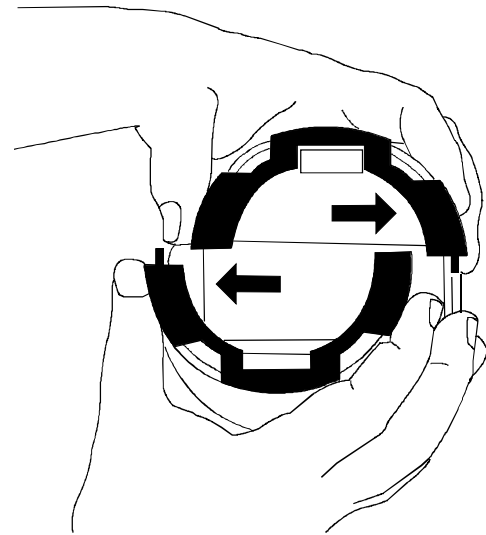

5. Gently pry off yoke bracket covering camera/lens board to access bearing assembly (Figure 31).

Figure 31. Removing the yoke brackets

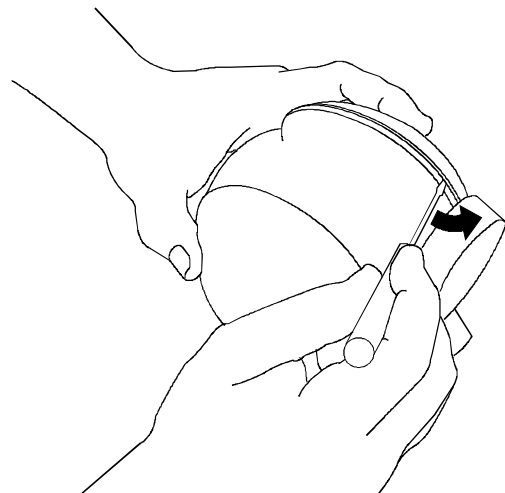

The following steps refer to Figure 32.

6. Access camera/lens board.
To do this, loosen captive retaining screw holding bearing assembly in place and remove this assembly.
7. Remove cables from camera/lens board.
 - a. Small amber ribbon cable is from tilt motor. Unplug this cable from connector J3 on camera/lens board.
 - b. Large gray ribbon cable is from slip ring connector. Unplug this cable from connector J2 on camera/lens board.

DO NOT unplug small white ribbon cable from connector J1.
8. Push out on three prongs to detach camera/lens board.
9. Reverse steps to reassemble.

Figure 32. Removing the camera/lens board

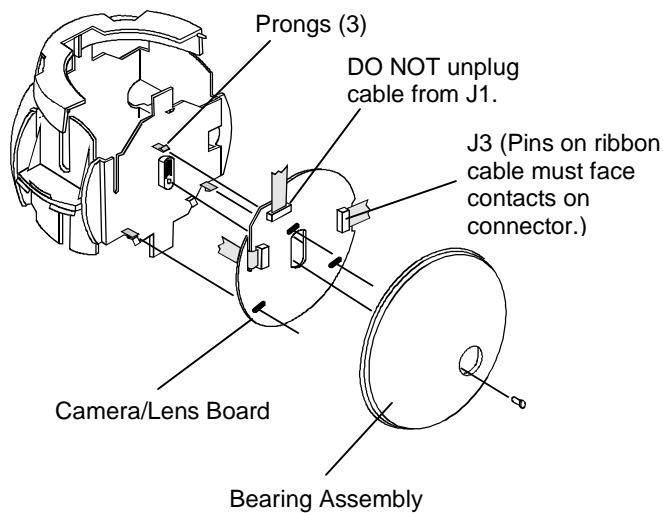

Removing the Tilt Motor

1. Perform procedure "Removing the Slot Covers" (page 29).
2. Perform procedure "Removing the Camera" (page 29).
3. Perform procedure "Detaching the Eyeball" (page 30).
4. Separate yoke brackets (Figure 33).

Figure 33. Separating the yoke brackets

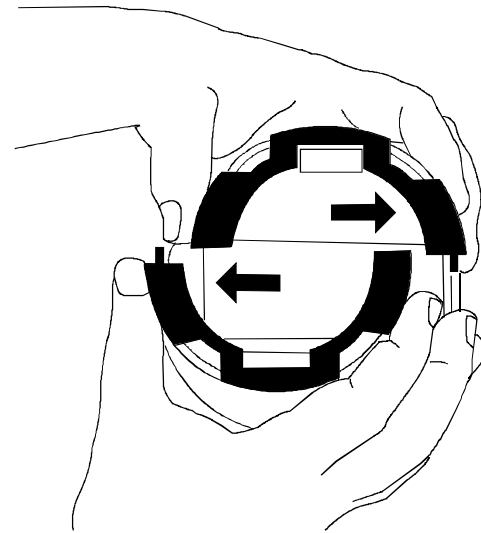

5. Gently pry off yoke bracket covering pan gear assembly to access tilt cable assembly (Figure 34).

Figure 34. Removing the yoke brackets

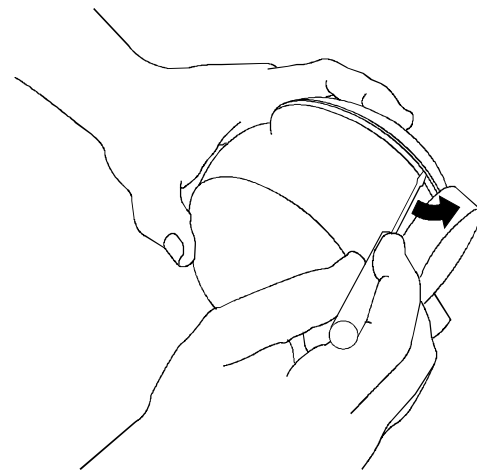

6. Access tilt motor.

To do this, loosen captive retaining screw holding tilt cable assembly in place and gently remove this assembly.

7. Remove tilt motor (Figure 35).

Lift motor housing up as shown (1) to disengage motor from tilt gear. Then pull motor bracket towards outside of cable/tilt assembly (2) to remove motor.

8. Reverse steps to reassemble.

CAUTION: When installing a new motor, be careful to properly mesh motor and tilt gears! Failure to do so can destroy both motor and tilt gear. Verify tilt gear turns freely!

Figure 35. Removing the tilt motor

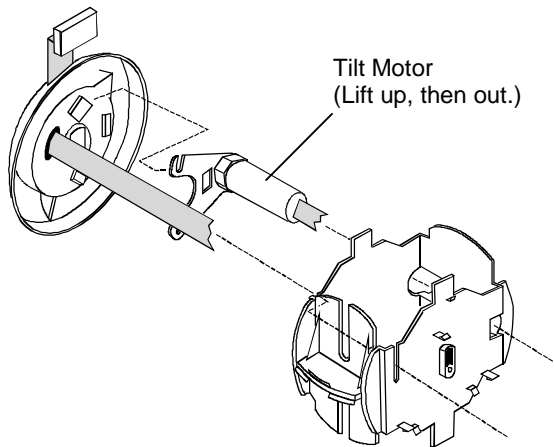

Updating/Reprogramming Dome Software

To update or reprogram dome software:

1. Remove flash memory chip.
Insert chip extractor tool into square access hole and squeeze to extract flash memory chip (Figure 36).

CAUTION: Electrostatic-sensitive device. Use a ground strap when handling chip.

2. Reprogram chip or replace it with new chip.
3. Reinsert chip.
Align dot on chip with indent on socket, then push down on chip to reinsert it.

Figure 36. Removing the flash memory chip

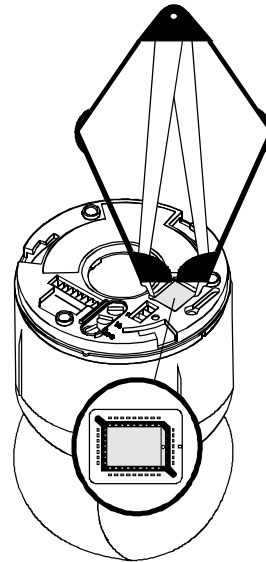

Ordering Parts

This section helps you to identify parts that make up the base and housing and eyeball assembly. Parts in Table 3 are shown in Figure 37.

Order parts through your parts distribution network.

Table 3. Parts list

1	Mounting Base	0400-1146-01
2	Video Cable Adapter, BNC to Micro	6003-0131-01
3	Plug, 4-Pin	2109-0572-04
4	Plug, 9-Pin	2109-0572-09
5	Lanyard	0500-8019-01
6	Screw, PH, M3 (Qty. 6)	5801-1051-120
7	Washer, Ext. Tooth, M3	5851-0200-041
8	Clip, Lanyard	0500-8046-01
9	Mounting Base	0500-7257-02
10	Ground Clip	0500-7293-01
11	I/O Board	0301-0546-01
12	Dust Cover	3100-0066-01
13	Screws, M3x8 PHP (Qty. 3)	5801-1071-111
14	Cap	0500-8021-02
15	CPU PC Board	0301-0948-03
16	Fan Cable Assy.	0650-2001-01
17	Standoff, M3x8Hx13L (Qty. 3)	5899-0055-01
18	Fan Plate	0500-8018-01
19	Screw, Thdcut, M3.5 (Qty. 2)	5899-0008-01

20	Standoff, M3x6Hx19L (Qty. 3)	5887-1122-020
21	Power Supply PC Board	5606-0015-01
22	Slip Ring Assy.	2100-0005-01
23	Pan Motor	3501-0017-01
24	Housing	0500-7255-02
25	Bearing Assy., Pan Gear	2510-0040-01
26	Skirt	0500-6710-01
27	Tilt Motor	3501-0018-01
28	Slot Cover (No Lens)*	0500-8037-01
29	Yoke, Camera	0500-7258-01
30	Camera/Lens PC Board	0301-0953-01
31	Bearing Assy., Lens Carriage	2510-0038-01
32	Yoke Bracket (Qty. 2)	0500-8038-01
33	Cable Assy., Tilt	0650-1680-01
34	Camera, 22x, NTSC	2003-0037-21
35	Camera, 22x, PAL	2003-0037-22
36	Camera, 22x, EIA	2003-0037-23
37	Camera, 22x, CCIR	2003-0037-24
38	Washer, Flat	2848-8100-08
39	Screw, 1/4-20 x 3/8	2802-7407-65
40	Screws, M2x3 (Qty. 4)	5801-0011-120
41	Tripod Mount	0500-6712-01
42	Slot Cover with Lens*	0400-1178-01

* Items 28 and 42 are supplied with the final assembly, not the eyeball assembly.

Figure 37. Base, housing, and eyeball assembly

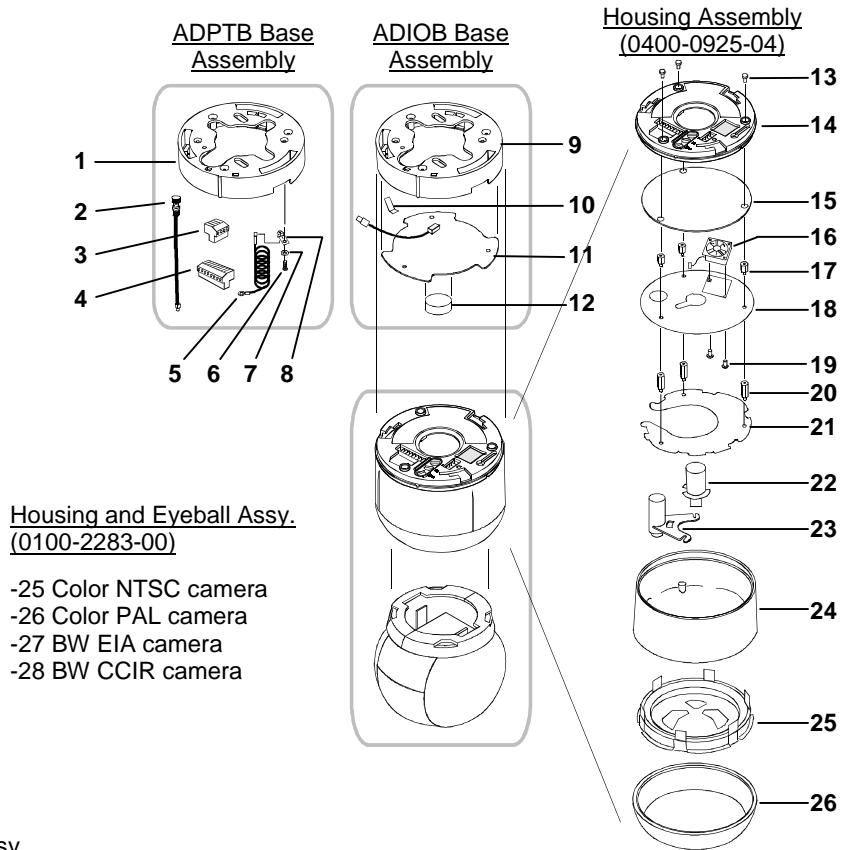

Eyeball Assy. (0400-0927-00)

- 21 Color NTSC camera
- 22 Color PAL camera
- 23 BW EIA camera
- 24 BW CCIR camera

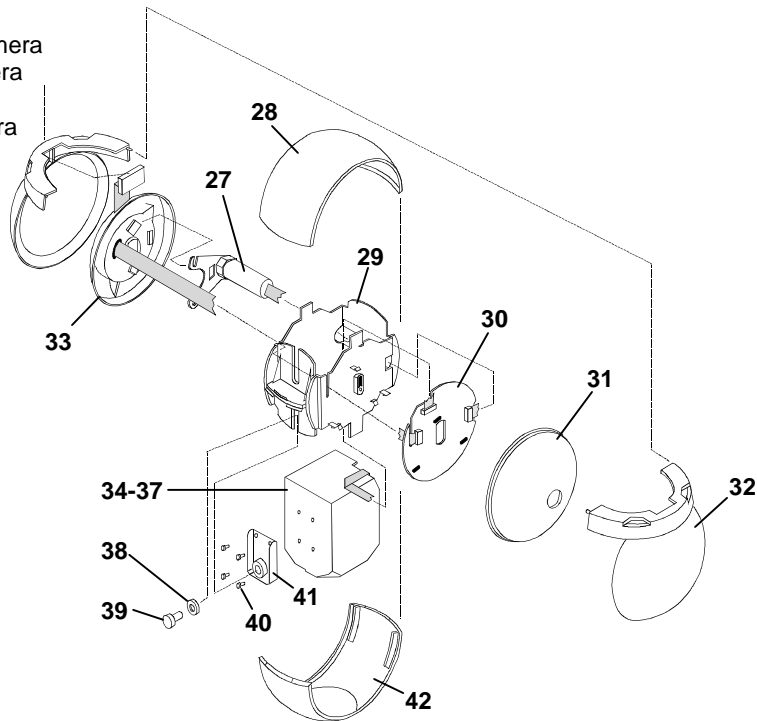

Specifications-Indoor Dome

Operational

Pan/Tilt:

Manual Pan/Tilt Speed 1°-100° per second
(scaled to zoom position)

Preset Pan/Tilt Speed..... 220° per second
maximum

Pan Travel 360° continuous rotation

Tilt Travel..... >90°

Pan/Tilt Accuracy..... ±0.5°

Zoom:

Optical Zoom 22X

Digital Zoom 8X

Zoom Pause 22X or 33X (default)

Zoom Stop 33X, 44X, 55X, 66X, 77X,
88X (default), 99X, 110X,
121X, , 132X, 143X,
154X, 165X, 176X

Zoom/Focus Accuracy..... ±0.5%

Auto Synchronization:

Line Locked Remote V-phase
adjustment

Internal Built-in sync generator

Address Range 1-255

Number of Presets:

VM16 / ADTT16 96 with SensorNet 485

VM32 / AD32 96 with SensorNet 485

AD2150 64 with Manchester
16 with RS422*

VM96 Virtual with RS422 or
SensorNet 485

VM168 / AD168 64 with Manchester,
RS422, or SensorNet
16 with RS422*

AD2050 64 with Manchester
16 with RS422*

Acquisition Time <1 second to position at
60% of zoom setting

Programmable Patterns 3

Program Storage..... 256 Kbytes of Flash
memory

Data Storage..... 128 Kbytes of SRAM

Menu Languages English, French, German,
Spanish, Italian, and
Portuguese

* Using AD2083-02A

Electrical

Input Voltage 24-30 Vac, 50/60 Hz
UL Class 2 LPS

Design Tolerance 16-36 Vac, 50/60 Hz

Current 0.85 A max.

Power On In-Rush Current... 1.5 A

Surge Protection:

Video Output 100 A

Power Line 60 V, 1.5 joules, 250 A

RS422 5.6 V, 0.1 joules, 40 A

Manchester/

SensorNet 485 Isolated transformer
coupled, 10 kA impulse
rated gas tube

Alarm Inputs 5.6 V, 0.1 joules, 40 A

Alarms Inputs/Control Outputs:

When no I/O board is used:

Inputs 1 dry contact/3.5 mA sink

Outputs..... 1 open collector driver
@ 12 Vdc, 40 mA

When I/O board is used:

Inputs 4 dry contacts/3.5 mA sink

Outputs..... 4 open collector drivers
@ 12 Vdc, 40 mA

Environmental

Operating Temperature -10° to 50°C (14° to 122°F)

Relative Humidity 0 to 95% non-condensing

Mechanical

Height 20.8 cm (8")

Diameter..... 12 cm (4.7")

Weight:

Housing and Eyeball 1.18 kg (2.6 lbs.)

Base (standard) 0.09 kg (.20 lbs.)

Base (with I/O board) 0.16 kg (.35 lbs.)

Lens and Bubble Densities

Eyeball Lens f0

Bubbles:

RUCLR (Clear)..... f0

RUSLV (Silver)..... f1.5 to f2

RUSMK (Smoke) f0.5

RUGLD (Gold) f1.5 to f2

Specifications-Outdoor Housing

Electrical (combined dome and housing)

Input Voltage.....	24 to 30 Vac, 50/60 Hz UL Class 2 LPS
Design Tolerance.....	20 to 36 Vac, 50/60 Hz
Power Consumption.....	80 W max.
Power On In-Rush Current.....	3 A
Surge Protection	Gas discharge tube impulse rated at 10kA (8/20µs impulse discharge current)
Alarm Relay:	
Contact Type	Form 1-C
Isolation	1000 V
Contact Rating.....	1 A at 30 Vac/dc

Environmental

Operating Temperature.....	-10°C to 50°C (-40°F to 122°F)
Relative Humidity	0 to 95% non-condensing
Storage Temperature	-40°C to 50°C (-14°F to 122°F)

Mechanical

Height.....	32.1 cm (12.6")
Diameter	24.4 cm (9.6")
Weight:	
Housing (alone)	2.6 kg (5.7 lbs.)
Housing (with dome).....	3.8 kg (8.4 lbs.)

Specifications-22X Camera

Color and B&W Cameras

Type	Interline transfer 1/4" CCD array
Scanning System	2:1 interlace
Video Out	1.0 Vp-p/75 ohms composite
Signal-to-Noise	50 dB (typical)

Color Camera Only

Horizontal Resolution	470 lines at center
Minimum Illumination.....	>1 lux (20 IRE, AGC on) 0.05 lux with field integration
White Balance	Through-the-Lens (TTL) Automatic Tracing White balance (ATW)

NTSC:

Effective Pixels	768 (H) x 494 (V) pixels
Scanning.....	525 lines, 60 fields, 30 frames
Horizontal.....	15.734 kHz
Vertical.....	59.9 Hz

PAL:

Effective Pixels.....	752 (H) x 582 (V) pixels
Scanning.....	625 lines, 50 fields, 25 frames
Horizontal.....	15.625 kHz
Vertical.....	50 Hz

B&W Camera Only

Horizontal Resolution	500 lines at center
Minimum Illumination.....	(TBD) lux (20 IRE, AGC on) (TBD) lux with field integration

EIA:

Effective Pixels.....	768 (H) x 494 (V) pixels
Scanning.....	525 lines, 60 fields, 30 frames
Horizontal.....	15.734 kHz
Vertical.....	59.9 Hz

CCIR:

Effective Pixels.....	752 (H) x 582 (V) pixels
Scanning.....	625 lines, 50 fields, 25 frames
Horizontal.....	15.625 kHz
Vertical.....	50 Hz

Lens Design

Type Aspherical
Focal Length 4 to 88 mm
Aperture f1.6
Viewing Angle (equivalent to 8-80 mm on 1/2" CCD array, or 11-110 mm on 2/3" CCD array):
4 mm 47.0°(H) x 35.2°(V)
64 mm 4.0°(H) x 3.0°(V)

Field-of-View Formulas:

$$\frac{3.2 \text{ mm}^* \times \text{distance from camera (m)}}{\text{Focal length (mm)}} = \text{Horizontal view (m)}$$
$$\frac{2.4 \text{ mm}^* \times \text{distance from camera (m)}}{\text{Focal length (mm)}} = \text{Vertical view (m)}$$

* Horizontal scanning area of pickup device (mm) in camera.
** Vertical scanning area of pickup device (mm) in camera.

Example: Wide angle view with lens at 4mm and viewed object at 10 m.

$$\frac{3.2 \text{ mm} \times 10 \text{ m}}{4 \text{ mm}} = 8\text{m Horizontal view (m)}$$
$$\frac{2.4 \text{ mm} \times 10 \text{ m}}{4 \text{ mm}} = 6\text{m Vertical view (m)}$$

Declarations

Regulatory Compliance

EMC 47 CFR, Part 15,
Class A
EN55022 CL. B
EN50082-1
Safety UL1950
CSA C22.2 No. 950
EN60950

FCC COMPLIANCE:

This equipment complies with Part 15 of the FCC rules for Class A digital devices when installed and used in accordance with the instruction manual. Following these rules provides reasonable protection against harmful interference from equipment operated in a commercial area. This equipment should not be installed in a residential area as it can radiate radio frequency energy that could interfere with radio communications, a situation the user would have to fix at their own expense.

CISPR 22:

WARNING: This is a class A product. In a domestic environment this product may cause radio interference in which case the user may be required to take adequate measures.

EQUIPMENT MODIFICATION CAUTION:

Equipment changes or modifications not expressly approved by Sensormatic Electronics Corporation, the party responsible for FCC compliance, could void the user's authority to operate the equipment and could create a hazardous condition.

Other Declarations

WARRANTY DISCLAIMER:

Sensormatic Electronics Corporation makes no representation or warranty with respect to the contents hereof and specifically disclaims any implied warranties of merchantability or fitness for any particular purpose. Further, Sensormatic Electronics Corporation reserves the right to revise this publication and make changes from time to time in the content hereof without obligation of Sensormatic Electronics Corporation to notify any person of such revision or changes.

LIMITED RIGHTS NOTICE:

For units of the Department of Defense, all documentation and manuals were developed at private expense and no part of it was developed using Government Funds. The restrictions governing the use and disclosure of technical data marked with this legend are set forth in the definition of "limited rights" in paragraph (a) (15) of the clause of DFARS 252.227.7013. Unpublished - rights reserved under the Copyright Laws of the United States.

American Dynamics
Sensormatic CCTV Systems Division
One Blue Hill Plaza
Pearl River, NY 10965
Technical Support Center 1-800-507-6268
Business (914) 624-7600