

SensorNet 6-Position Junction Box (J-Box)

This box provides power and data communications for up to six SpeedDome or SpeedDome Ultra camera domes. It also supports up to two outdoor domes (one per group of ports, P1–3 or P4–6) or a combination of up to one outdoor dome and three indoor domes, with the following restriction: if powering an outdoor dome, no other dome can be plugged into the same group of connectors (P1–3 or P4–6).

IMPORTANT: Regulatory Requirements and other declarations on page 4.

Figure 1. J-Box Components

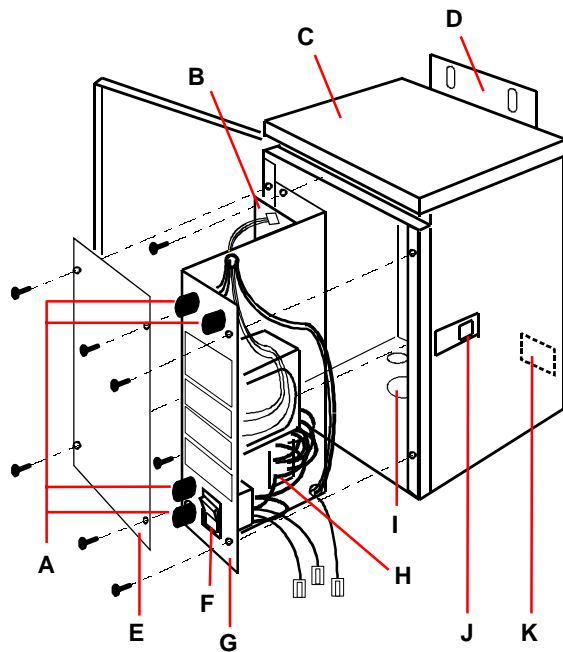

- | | |
|---------------------|------------------|
| A. Fuses | G. Chassis |
| B. PC board (PCB) | H. TB1 connector |
| C. Enclosure | I. Knockouts |
| D. Mounting Bracket | J. Latch |
| E. Cover plate | K. TB2 connector |
| F. On/Off switch | |

Installation Requirements

WARNINGS

- NEVER PIERCE the enclosure.
- This installation should be made by qualified service personnel and conform to the National Electrical Code and applicable local codes.
- The product shall be located so as to provide protection against unintentional operation by employees, janitors and cleaners working about the premises, by falling objects, by customers, and by building vibration.

The installation must satisfy the following requirements:

- Follow the SensorNet Network Guide section to ensure proper network design.
- Minimize exposure to environmental extremes by mounting the J-Box and the SpeedDome in a sheltered area when possible.
- Always use dedicated, unswitched 24-hour AC power, supplied in accordance with local codes and with proper grounding.
- Ensure that the J-Box's power On/Off switch and fuses are accessible.
- Always use the four mounting bolts for wall and pole mount installations.
- Use the clamp package provided when banding a camera dome to a pole.

Installation Process

Parts Required

Installation Kit (0351-0739-01) includes:

a) Anchor, toggle and bolt, 1/4x4	4	2880-0040
b) Anchor, wedge, bolt, 1/4x4	4	2880-0052
c) Screw, #10x1-1/24	4	2812-7816
d) Flat washer, wide, type B, #10	4	2848-9306
e) Conn, Plug Tublr, 1 x 4 Posn	6	2109-0254-03
f) Conn, Plug, Tublr 1 x 5 Posn	6	2109-0254-04
g) Grommet, Edge, Continuous	1ft	3100-0029-01
h) Bushing, STR RLF	1	3100-0035-11

Mounting the J-Box

1. Disconnect power to J-Box at circuit breaker.
2. Remove the four screws from the cover plate and remove the plate.
3. Remove the four screws securing the chassis to the enclosure.
4. Disconnect the wires from TB2 and remove the chassis from the enclosure.
5. Remove the necessary knockouts from the bottom plate of the enclosure to provide data and power cable access.
6. Using the enclosure's mounting brackets as a template, mark the mounting hole locations on the designated area of the wall.
7. Drill holes at the marked areas to accommodate the required mounting hardware.
8. Secure enclosure in place using either four hollow wall anchors for sheetrock, concrete anchors for blocks, or wood screws for plywood.
9. Pull the cables through the knockout holes in the bottom plate and align the conduit (if any) with the holes.

Connecting Power to the J-Box



230Vac operation requires changes to chassis jumpers and fuses. Refer to the chassis panel for details.

1. Remove cover plate and chassis (Figure 1) to access connector TB2 at rear of enclosure.
2. Connect incoming AC wires to the TB2 connector for 115Vac or 230Vac operation using Figure 2 and its associated tables.

Figure 2. TB2 Power Connections

Chassis Connections

Color	Pin	Function
Green/ Yellow	E1	Ground
Black	2	Neutral
Black	3	Line

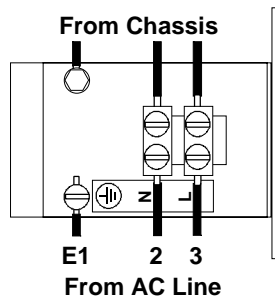

AC Line Connections

Color	International	Pin	Function
Green/Yellow	E1	Ground	
Blue	2	Neutral	
Brown	3	Line	

Connecting Power to the PC Board

1. Replace the four screws that secure the chassis in the enclosure.
2. Connect AC power to the printed circuit board (PCB) by inserting the polarized connector from the chassis into the P7 connector on the PCB. See Figure 3.

Figure 3. Top View and P7 Connector

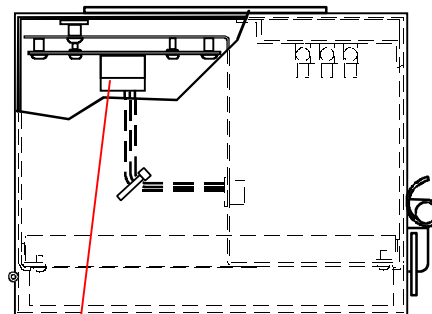

PCB Power Connector (P7)

P7 Connector

Color	Pin	Function
Black	4	28Vac
Green	5	Ground
Black	6	28Vac

Connecting the Camera Dome to the J-Box

Video cables are connected directly to the video control system—not terminated at the J-box. Power and data lines must be connected to the J-box.

Video Cable Connection

Attach the video cable from the camera dome to the appropriately labeled cable leading to the video control system.

Power and Data Connections and Terminations

IMPORTANT: See top of Page 1 for restrictions on the number of outdoor domes connected to P1–P6.

1. Strip the three power and two data leads from the composite cable and attach them to a 5-position compression connector, following the P1–P6 Connector table from Figure 4.
2. Plug the compression connector into an available port (P1–P6) on the PCB.
3. Wire the SensorNet data cable coming from the host device (and any cables going to an auxiliary J-Box or other SensorNet device) to a 4-position compression connector, following the P8 Connector table from Figure 4.
4. Plug the compression connector into port P8 on the PCB.
5. Set jumpers JW1, JW2, JW3, and JW4 on the PCB (see Figure 4) to the correct position. Shorting pins 1–2 terminates the device. Refer to the SensorNet Network Guide to determine the necessary terminations for the chosen network topology.

Figure 4. PCB Connectors and Jumpers

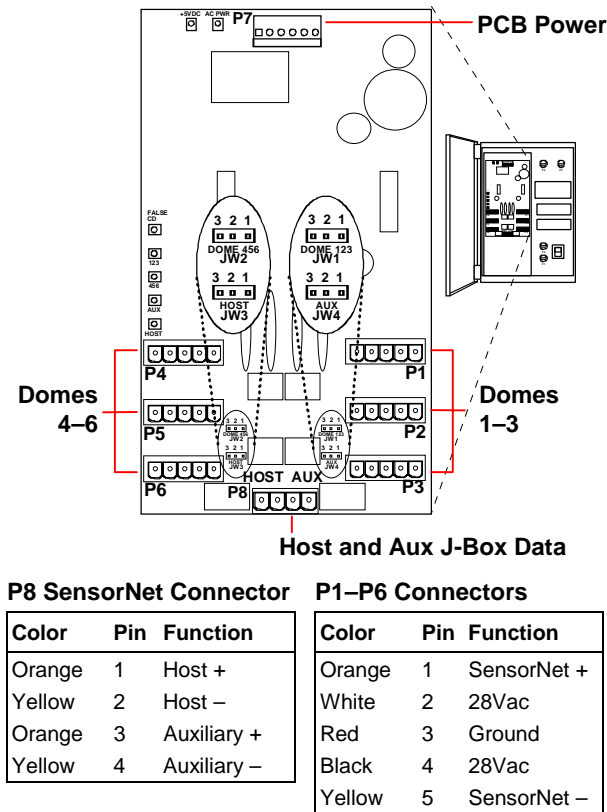

Data and Power LED Indicators

The LED indicators on the PCB (see Figure 5) allow visual verification of SensorNet signals and power to the dome port and host/auxiliary ports. They illuminate to indicate the following conditions:

- **AC PWR** is yellow when 24Vac from the transformer to the PCB is present.
- **+5VDC** is green when DC power from the on-board regulator is present.
- **FALSE CD** is red for 0.5 sec if the device receives a false pulse (indicating noise on the SensorNet cable).
- **123** is yellow for 30ms to indicate communications activity from dome ports 1, 2, or 3.
- **456** is yellow for 30ms to indicate communications activity from dome ports 4, 5, or 6.
- **AUX** is yellow for 30ms to indicate communications activity from the auxiliary port.
- **HOST** is yellow for 30ms to indicate communications activity from the host port.

Figure 5. On-Board LEDs

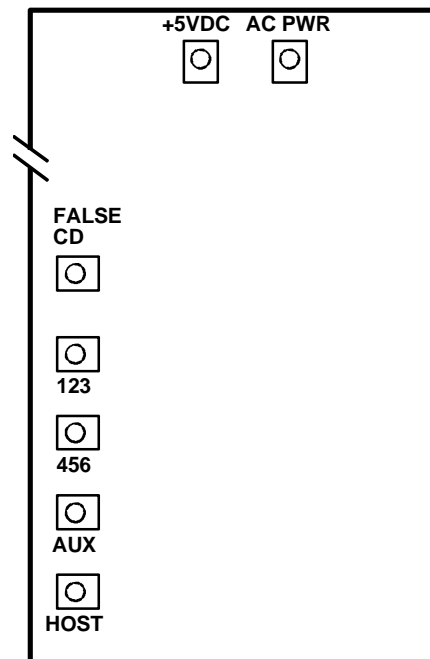

Specifications

Electrical

Power Source	100–120/200–240Vac 1.6A/.08A, 50–60Hz
Power Consumption:	250W max.
Voltage Output:.....	28Vac, 3A per Class 2 output, 6A total. Do not parallel outputs. For dry location.
Fuses F1, F2:.....	2A, 250V, Slow Blow
Fuses F3, F4:.....	6.3A, 250V, Slow Blow

Dimensions

Height:	32cm (12.6in)
Width:	21cm (8.3in)
Depth:	16cm (6.3in)
Weight:	8.5kg (18.7 lb)

Declarations

Regulatory Requirements

This product can only be used with American Dynamics products.

When the unit is hard wired, the disconnect device (circuit breaker) must be readily accessible.

Use only polarized plug/cordsets; non-polarized plugs invalidate regulatory approvals. Use only approved cordsets.

The socket outlet must be installed near the equipment and easily accessible.

Regulatory Compliance

REG ID: JB-SNET

FCC COMPLIANCE: This equipment has been tested and found to comply with the limits for a Class A digital device, pursuant to Part 15 of the FCC Rules. These limits are designed to provide reasonable protection against harmful interference when the equipment is operated in a commercial environment. This equipment generates, uses, and can radiate radio frequency energy and, if not installed and used in accordance with the instruction manual, may cause harmful interference to radio communications. Operation of this equipment in a residential area is likely to cause harmful interference in which case the user will be required to correct the interference at his own expense.

EQUIPMENT MODIFICATION CAUTION: Equipment changes or modifications not expressly approved by Sensormatic Electronics Corporation, the party responsible for FCC compliance, could void the user's authority to operate the equipment and could create a hazardous condition.

Other Declarations

Thank you for using American Dynamics products. We support our products through an extensive and worldwide network of dealers. The dealer through whom you originally purchased this product is your point of contact if you have a need for service or support. Our dealers are fully empowered to provide the very best in customer service and support. Dealers should contact American Dynamics at (800) 507-6268 or (561) 912-6259 or on the web at www.americandynamics.net.

WARRANTY DISCLAIMER: Sensormatic Electronics Corporation makes no representation or warranty with respect to the contents hereof and specifically disclaims any implied warranties of merchantability or fitness for any particular purpose. Further, Sensormatic Electronics Corporation reserves the right to revise this publication and make changes from time to time in the content hereof without obligation of Sensormatic Electronics Corporation to notify any person of such revision or changes.

LIMITED RIGHTS NOTICE: For units of the Department of Defense, all documentation and manuals were developed at private expense and no part of it was developed using Government Funds. The restrictions governing the use and disclosure of technical data marked with this legend are set forth in the definition of "limited rights" in paragraph (a) (15) of the clause of DFARS 252.227.7013. Unpublished - rights reserved under the Copyright Laws of the United States.

REVISION NOTICE: The information in this manual was current when published. The manufacturer reserves the right to revise and improve its products. All specifications are therefore subject to change without notice.

TRADEMARK NOTICE: American Dynamics, SpeedDome, and Sensormatic are trademarks or registered trademarks of Sensormatic Electronics Corporation. Other product names (if any) mentioned herein may be trademarks or registered trademarks of Sensormatic or other companies. Trademarked names are used throughout this manual. Rather than place a symbol at each occurrence, trademarked names are designated with initial capitalization. Inclusion or exclusion is not a judgment on the validity or legal status of the term.

COPYRIGHT NOTICE: Under copyright laws, the contents of this document may not be copied, photocopied, reproduced, translated or reduced to any electronic medium or machine-readable form, in whole or in part, without prior written consent of Sensormatic Electronics

© Copyright 1997–2003 Sensormatic Electronics Corporation
mhj 05/2004