

SensorNet Single-Position Junction Box (J-Box) Installation Guide

Figure 1. SensorNet J-Box

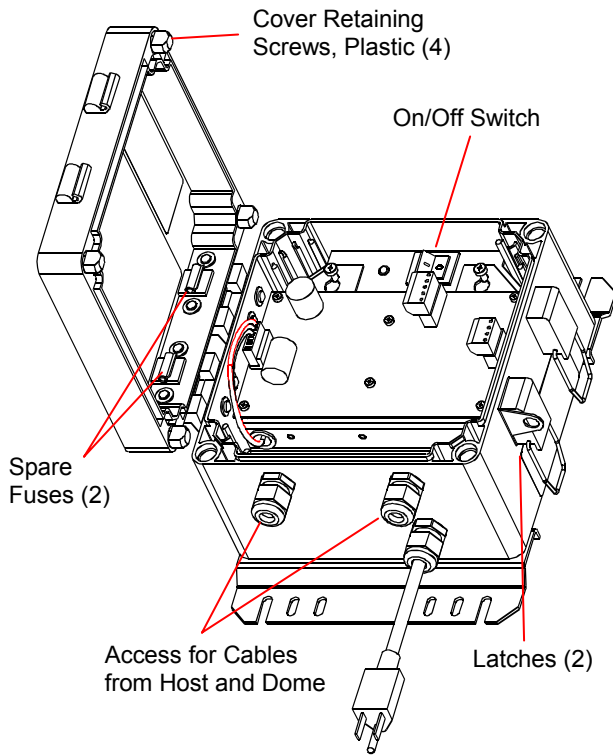

RJ1SNUD and RJ1SNUD-1 Series

This weather-tight box (Figure 1) provides Class 2 LPS power and data to the new SpeedDome Ultra outdoor camera housing.

IMPORTANT: Read Regulatory Requirements and other declarations on page 8.

IMPORTANT SAFEGUARDS

The J-Box is a 10A, 2-pole, ganged disconnect device, which also provides short circuit and overload protection, and has a minimum 3mm open circuit clearance, in accordance with the National Electric Code and applicable local codes must be installed at a location readily accessible to the equipment.

(Ein 10A, 2-poliges, gekoppeltes Ausschaltgerät, welches auch über einen Kurzschluß- sowie Überbelastungsschutz verfügt, und einen minimum 3mm offenen Schaltabstand aufweist, nach Übereinstimmung mit den Nationalen Elektrischen Regelungen sowie lokalen Regeln, muß an einem Standort installiert werden, welcher einfachen Zugang zum Gerät erlaubt.)

Outside elements: To keep outside elements from entering the J-Box, always mount it vertically with cable exits facing down, and tighten the four plastic screws.

Adding access holes to the enclosure: The J-Box meets the NEMA 4 standard for weatherproofing. To maintain this rating, make sure any hole you drill in the enclosure is thoroughly sealed with silicone-based RTV compound.

Switching to 240Vac: If using 240Vac to drive the J-Box, you must change jumper terminations on the primary winding of transformer. Refer to label inside cover of J-Box.

Approved power cords: Use only regulatory-approved polarized power cords.

Socket-outlet: For installation using a line cord, the socket-outlet must be installed near the equipment and at an easily accessible location.

(Für Installationen mit einem Stromkabel muß die Steckdose an einem Standort installiert werden, welcher einfachen Zugang erlaubt.)

This product does not support Manchester protocol: It will support SensorNet.

USE ONLY WITH American Dynamics products and other approved products from Sensormatic Electronics Corporation.

See inside for additional safeguards.

SensorNet Single-Position J-Box Specifications

REG ID: SV JBOX1

Product Codes

RJ1SNUD	120V with North American line cord
RJ1SNUD-1	230V with Continental European line cord

Transformer primary jumpers and mains line cord are field changeable to support either 120Vac or 230Vac

Electrical

Power source	100–120Vac or 200–240Vac, 50/60Hz
Fuse	3.15A type IEC127, sheet III
Max. operational limits	90–135Vac or 180–265Vac, 50/60Hz
Input current	1.0A/.5A
Output	26Vac, 2.4A max. Class 2 LPS
Power line protection	Gas Discharge tube impulse rated at 8/20µs impulse discharge current: 10kA

Operational

Diagnostic LEDs	Host, aux., dome activity, noise, power
Power	On/Off switch
Compatible with	SpeedDome Ultra outdoor housing

Mechanical

Environment	Indoor / Outdoor
Wall mounting options	concrete, wood, sheet rock
Dimensions (H x W x D)	200 x 200 x 132mm (7.87 x 7.87 x 5.19 in.)
Mounting area (H x W)	281 x 200mm (11 x 8 in.)
Weight	3.7 kg (8.25 lbs)
Construction	Polycarbonate, non-metallic enclosure
Color	Light gray
Cover locks	2 quick-release latches
Cable access	3 ½-inch NPT strain relief fittings provided for power, host, and dome cables.

SensorNet Communication Interface

Cable distance:

J-Box to J-Box	1km (3000ft)
Host to J-Box	1km (3000ft)
J-Box to camera dome	Limited by the length of the low-voltage ac power cable. See Table 1 on page 6.

Cable type

1unshielded twisted pair, 22AWG, non-polarized

Surge protection

Isolation transformer coupled, 2000 Vrms, gas discharge tube impulse rated at 10kA, 8/20µs, TVS rated at 1W.

Connectors for host, aux., and dome

Pluggable Euro-style

Environmental

Weatherproof standard	NEMA 4 / IP66
Operating temperature	–40°C to 50°C (–40°F to 122°F)
Storage temperature	–10°C to 50°C (14°F to 122°F)
Relative humidity	0 to 95% non-condensing

Regulatory

EMC	47 CFR, Part 15, Class A EN55022, Class B
Immunity	EN50082-1
Safety	UL1950 CSA 22.2, No. 950 EN60950

See additional declarations on last page.

Mounting the J-Box

This section explains how to mount the J-Box to a wall or pole.

Parts Required

Installation Kit (0351-1646-01) includes:

Screw, Self-tapping, 4.8x25, PHP	4	5810-5081-111
Anchor Bolt, ¼-20x2¼, w/Hardware	4	2880-0011
Anchor, Toggle, Nylon, #8-#10 Screw	4	2880-0073-01

CAUTION: Before you begin, do the following:

- Mount the box near an accessible ac outlet.
- Always use dedicated, unswitched, and properly grounded 24-hour ac power. Power should be supplied in accordance with local codes.
- Mount the J-Box so its power on/off switch is readily accessible and its strain relief fittings are face down.

Indoor Wall Mounting

Mount the J-Box to the wall as follows (Figure 2):

1. Using the upper and lower mounting brackets of the box as templates, mark mounting hole locations. The two center top slots in the upper bracket match the bolt spacing used for older J-Boxes.

CAUTION: J-Box meets NEMA 4 standard for weatherproofing. To maintain this rating, ensure holes drilled in the enclosure are thoroughly sealed with silicone-based RTV compound. All outdoor wiring must be through conduit, and tighten the four plastic screws.

2. Install the J-Box to drywall, concrete, or wood (see note below).
 - *Drywall:* Use four self-tapping screws and Nylon anchors provided.
 - *Concrete:* Use four anchor bolts provided. Use a 6.3mm (1/4in) masonry bit (not provided) to drill screw holes.
 - *Wood:* Use four self-tapping screws.

Note: To facilitate installation, use the two open slots in the lower mounting bracket to rest the box on the screws while inserting screws through the upper bracket.

3. Tighten mounting hardware to secure the J-Box.

Figure 2. Wall-mounting the J-Box

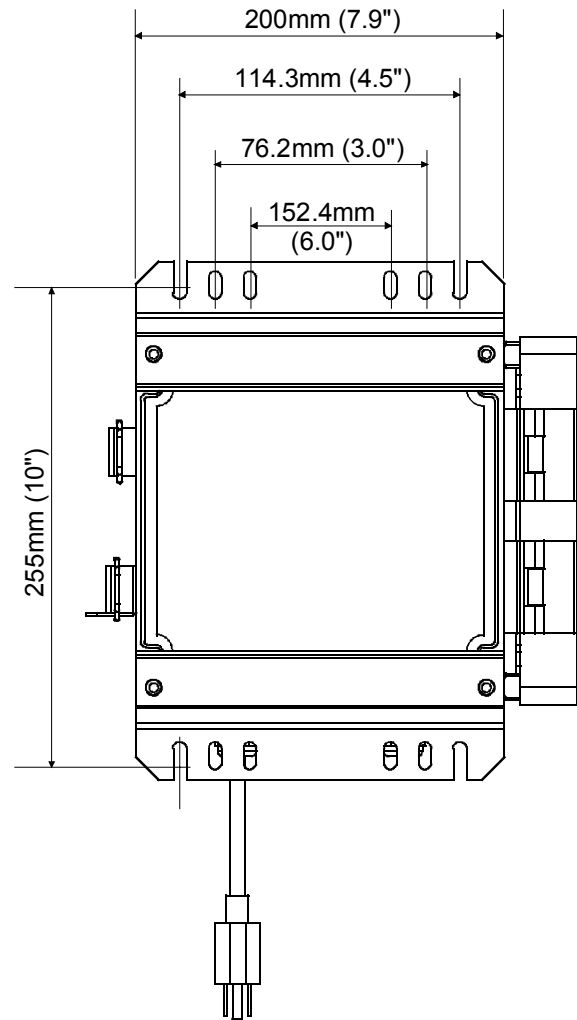

Outdoor Pole Mounting

Outdoor mounting (Figure 3) requires that PC board, chassis, and power cord be removed to facilitate attachment to pole. PC board and chassis are reattached once box is secured.

Note: Pole Mount Kit RHOPM, supplied with the pole mount structure, includes straps sufficient for 10–30.5cm (4–12in) wide poles. For larger widths, order an additional kit.

Figure 3. Outdoor pole mount

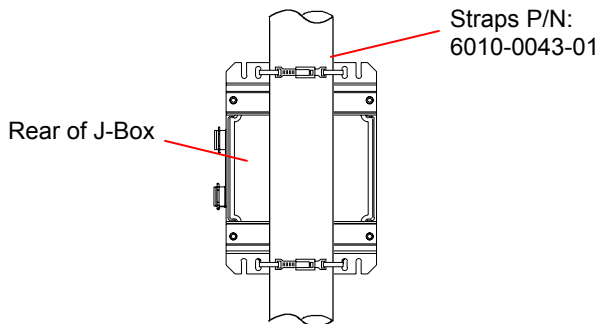

1. On the ground:
 - a. Remove PC board assembly and chassis assembly from box (Figure 4a).
 - b. Remove power cord and attach conduit to box. Ensure connections are liquid-tight.
 - c. Remove racks, screw assemblies, and band from clamp package. Carefully uncoil band and cut it in half to form two bands.
 - d. With words “this side up” etched in rack facing up, insert rack into screw assembly (Figure 4b). Then turn screw just enough to engage rack. Prepare two racks this way.
2. As shown in Figure 4c, with J-Box on ground and its rear facing towards you:
 - a. Slip one of the two bands through closed slots in lower mounting bracket. Pick slots appropriate for the width of the pole.
 - b. Bend end of left side of band inward.
 - c. Slip bent end through large slot in screw assembly and flatten tight with fingers.
 - d. Repeat for upper mounting bracket.
3. Place box in its mounting location against pole. Then wrap both band assemblies around pole so screws are opposite J-Box.
4. Holding J-Box in place, perform the following for each band:
 - a. Cut band to length at a point 2.54cm (1in) beyond first notch in band (Figure 4d).

- b. Using your fingers, flatten the last 2.54cm (1in) of band inward to form a hook. Insert hook through remaining slot in rack and turn screw to secure J-Box to pole (Figure 4e).
5. Run cables and attach wires. See “Connecting AC Power” and “Connecting Power and Data Cables”. **Caution:** Do not use power cord supplied with box for outdoor installations.

Figure 4. Pole-mount—details

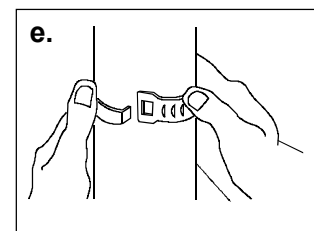
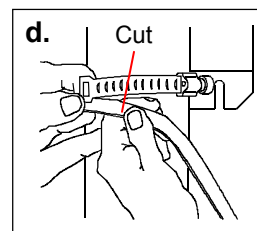
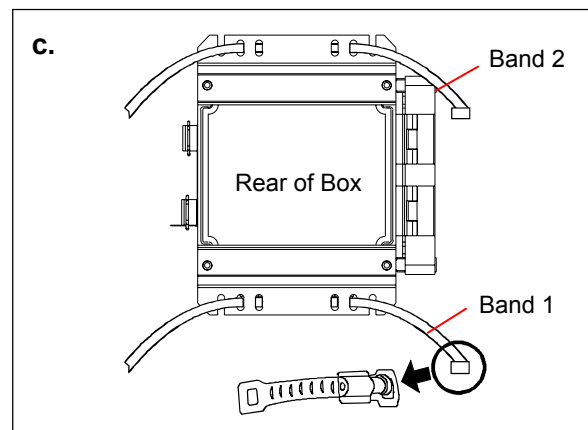
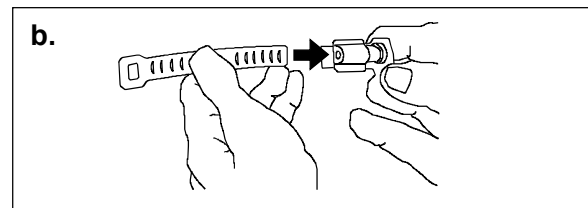
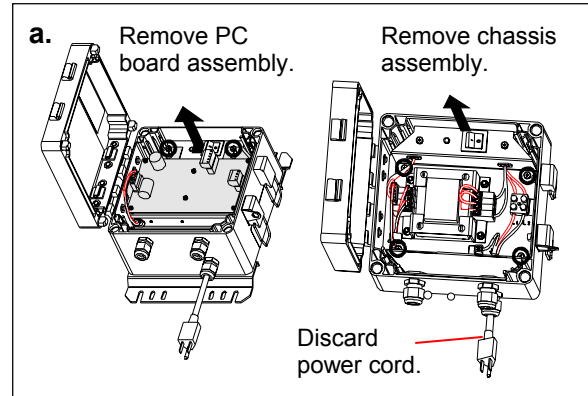

Connecting AC Power

The J-Box comes wired for 120Vac and has a 2m (6ft 7in) SJT 3-conductor power cord attached. Plug the cord into a dedicated 24-hour, unswitched outlet.

If the box is to be driven by 240Vac, then the power cord (if used) and jumpers across the primary winding of the transformer within the box will have to be changed (Figure 6).

CAUTION: Use only regulatory-approved polarized power cords.

Hardwiring the J-Box

If the box is to be hardwired to the ac source, then the chassis within the box and the power cord will have to be removed to facilitate connection. Refer to Figures 5, 6, and 13 for how to remove these parts.

CAUTION: Keep the disconnect device (circuit breaker) readily accessible when hardwiring J-Box.

Do the following:

1. Unplug line cord from ac outlet.
2. Loosen two screws, then slide and lift PC board assembly to remove and access ac connections (Figure 5).

Figure 5. Accessing connections

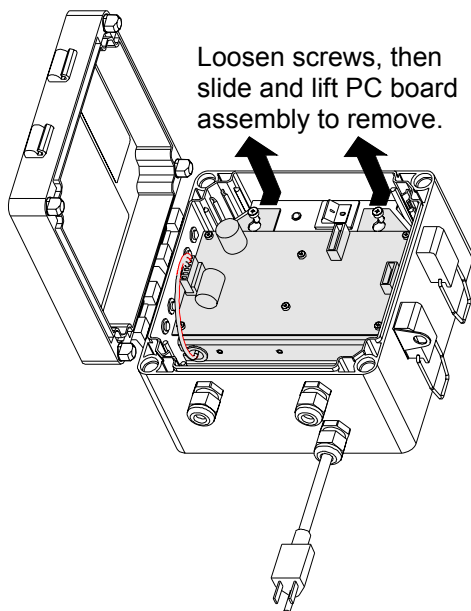

3. Disconnect ac power cord from TB1 (Figure 6).
4. Loosen four screws to detach chassis.
5. Detach strain relief securing cord and remove cord (refer to Figure 12).

Figure 6. Transformer compartment detail

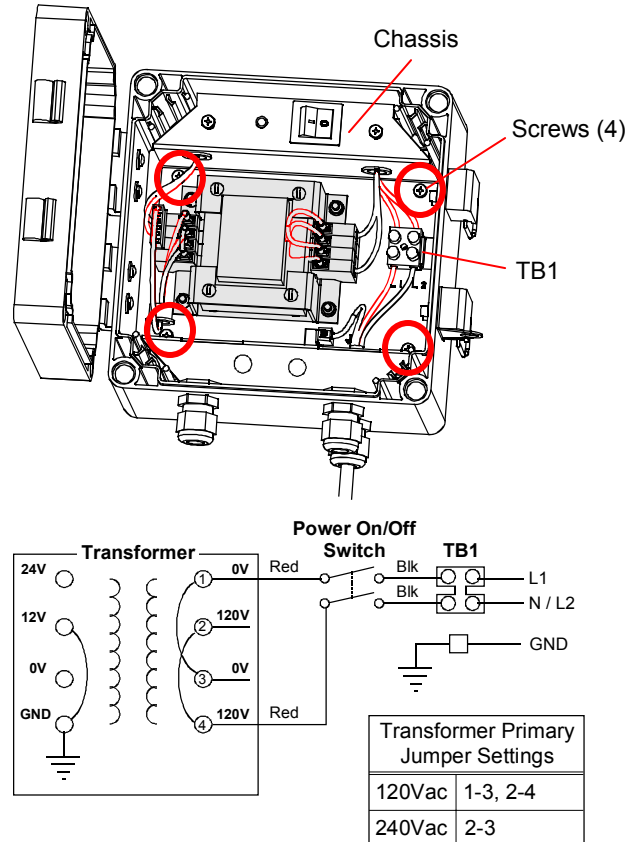

Chassis Connections

Color	Pin	Function
Green/ Yellow	E1	Ground
Black	2	Neutral (N / L2)
Black	3	Line (L1)

AC Line Connections

Pin	Function
E1	Ground
2	Neutral (N / L2)
3	Line (L1)

- Run conduit and ac cable to box and clamp conduit in place (Figure 7).
- Reattach chassis.

Figure 7. Conduit attachment

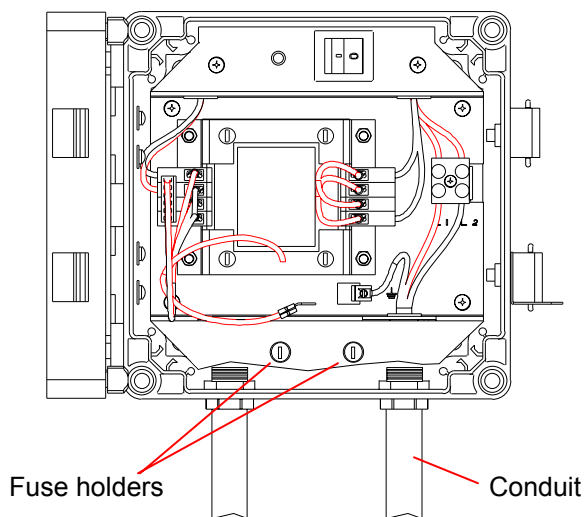

- Wire ac line to TB1 and jumper primary taps of transformer according to ac source (refer back to Figure 6).
 120Vac: Place a jumper across taps 1 and 3, and another jumper across taps 2 and 4.
 240Vac: Place a jumper across taps 2 and 3 only.
- Reattach PC board assembly.

Changing the Fuse

To reduce the risk of fire, replace fuses with the same type and rating (3:15A type IEC127, sheet III). The part number for the fuse is 5111-0017-21. Two spare fuses are provided inside the cover.

To access fuse, use a small slotted screwdriver to unscrew the cap of the fuse holder (Figure 7) and lift out the fuse.

Connecting Power and Data Cables

Note: Incoming and outgoing video cables are connected together within the box. No termination exists for video cables within the J-Box.

Power Cable Requirements

The low-voltage power cable runs between the J-Box and the camera dome. The length of this cable depends on the ac line voltage. See Table 1 for cable lengths based on worst case low line voltages for Japan (100Vac), North America (120vac), and Europe (240vac).

Table 1. Cable length vs. line voltage

Worst Case Line Voltages	18AWG	16AWG	14AWG
90 Vac (Japan)	30m (100ft)	50m (160ft)	80m (260ft)
102 Vac (N. Amer.)	60m (200ft)	100m (320ft)	160m (520ft)
180 Vac (Europe)	30m (100ft)	50m (160ft)	80m (260ft)
204 Vac (Europe)	60m (200ft)	100m (320ft)	160m (520ft)

Data Cable Requirements

The data cable contains one non-polarized 22AWG, unshielded, twisted pair. Up to 1km (3000ft) of data cable can be run from the Host to the J-Box, or from J-Box to J-Box (see CAUTION below). For more information about the SensorNet communication protocol and possible cable network configurations, see *Communication Protocols and Cable Networks*, 8000-2573-19.

CAUTION: The data cable from the J-Box to the dome is limited by the length of the power cable. See Table 1 above.

Note: Power, data, and video cables can be ordered separately or within a composite cable ordered in various lengths. Plenum-rated cables must be used in indoor ceilings used for environmental air return (called "other air space" in the National Electrical Code). Order parts through your distribution network. If you order cable from an outside source, wire colors may be different.

Procedure

1. Turn power switch in J-Box to off (0). Power LED should be off.
2. Route power and data cables through strain relief fittings in bottom of box.

Referring to Figure 8:

3. Connect power and data cables to 5-pin compression connector (supplied on board). Color code shown is for composite cable.

5-Pin Compression Connector

Pin	Wire Color	Description
1	YEL	SensorNet
2	WHT	AC
3	RED	Ground
4	BLK	AC
5	BRN	SensorNet

4. Plug 5-pin connector into receptacle P1.
5. Connect auxiliary and host data cables to 4-pin compression connector P8 (supplied on board). Color code shown is for composite cable.

4-Pin Compression Connector

Pin	Wire Color	Description
1	YEL	Host
2	BRN	Host
3	YEL	Aux.
4	BRN	Aux.

6. Plug 4-pin connector into receptacle P8.
7. Place jumper JW1 (Dome) across pins 1–2 to terminate J-Box (default setting) when the J-Box is to be the end point of a data line. Place JW1 across pins 2-3 (unterminated) if the J-Box is to be the hub of a star network.

For jumpers JW2 and JW3: See *Communications Protocols and Cable Networks*, 8000-2573-19.

Figure 8. PCB connectors and jumpers

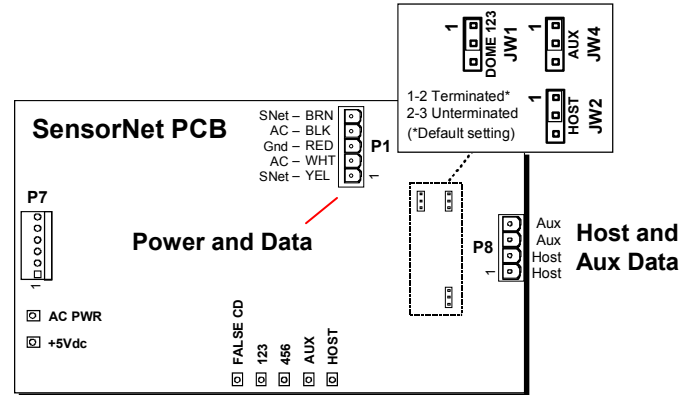

Testing for Power and Data

LEDs on the circuit board (Figure 8) verify that power and data are entering the J-Box.

LED	Indication
AC PWR	Glows yellow to indicate 24 volt AC power from transformer.
+5Vdc	Glows green to indicate DC power from on-board regulator.
False CD	Glows red for 1/2 sec. to indicate spurious false carrier detects.*
Carrier Detect 123	Glows yellow to indicate communications from connector P1 to dome.* (Carrier Detect 456 is not used.)
Carrier Detect Aux.	Glows yellow to indicate communications from auxiliary device.*
Carrier Detect Host	Glows yellow to indicate communications from Host.*

* Retriggerable indicators remain on if triggered faster than the remaining time.

Troubleshooting

Problem	Possible Solution
No Power	<p>First check both fuses, then look for open or loose wire connections at TB1. If loose, reconnect wires.</p> <p>Measure voltage across 0 and 24V taps of secondary winding on transformer. If open, replace transformer. See "Removing the Transformer" opposite.</p>
No Data	<p>Check for loose wires. If OK, see "Testing for Power and Data" on page 7.</p>

Removing the Circuit Board

Follow steps to remove the circuit board. Reverse steps to reassemble.

1. Loosen four captive screws to release cover.
2. Remove six screws to remove circuit board (Figure 9).

Figure 9.

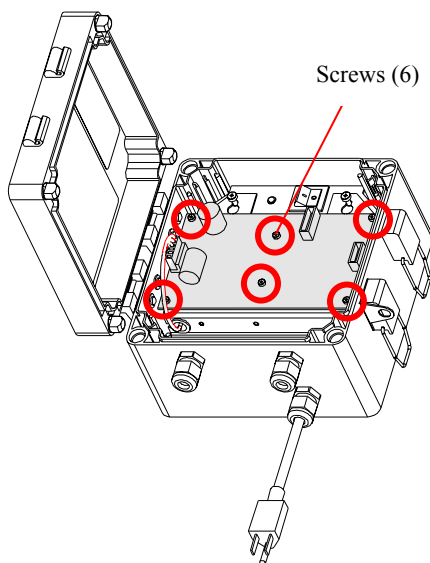

Removing the Transformer

Follow steps to remove the transformer. Reverse steps to reassemble.

1. Loosen four captive screws to release cover.
2. As shown in Figure 10, loosen two screws shown in and slide chassis in direction of arrows. Gently lay chassis on inside front cover while working on transformer. Slide PCB chassis out of box.

Figure 10.

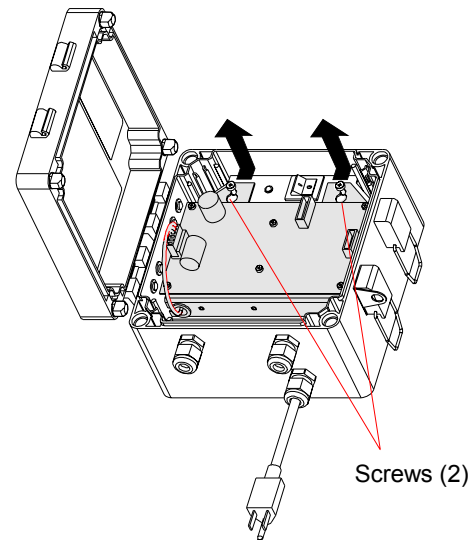

3. Remove four nuts to remove transformer (Figure 11).

Figure 11.

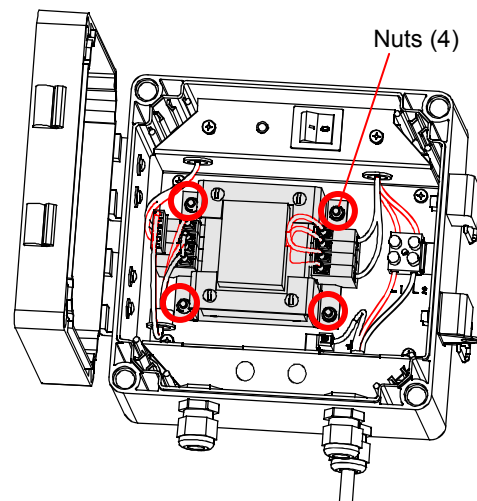

Ordering Parts

Only the following parts can be ordered:

- SensorNet PC Board 0312-0512-02
- 5-Pin Connector 2109-0254-04
- 4-Pin Connector 2109-0254-03
- Power Transformer 5604-0205-01
- Cable Strain Relief 3100-0035-11
- Fuse 5111-0017-21.

These parts are shown bold in Figure 12.

Figure 12. Exploded view of SensorNet J-Box

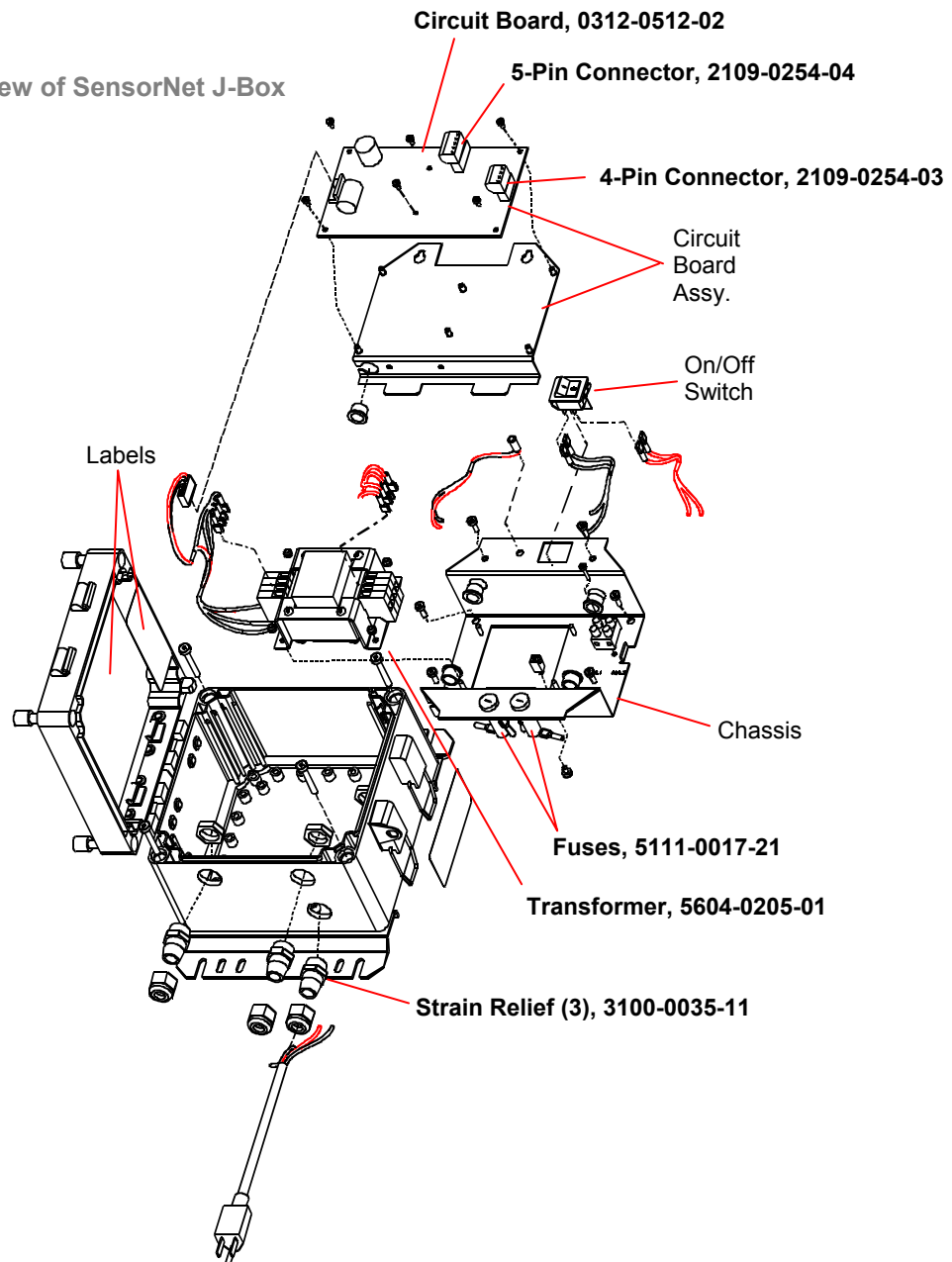

Declarations

This product can only be used with American Dynamics products and other approved products from Sensormatic Electronics Corporation.

When the unit is hard wired, the disconnect device (circuit breaker) must be readily accessible.

To meet regulatory approvals, only use approved polarized plug/cordsets. Install the AC outlet near the equipment where it is easily accessible.

FCC COMPLIANCE: This equipment has been tested and found to comply with the limits for a Class A digital device, pursuant to Part 15 of the FCC Rules. These limits are designed to provide reasonable protection against harmful interference when the equipment is operated in a commercial environment. This equipment generates, uses, and can radiate radio frequency energy and, if not installed and used in accordance with the instruction manual, may cause harmful interference to radio communications. Operation of this equipment in a residential area is likely to cause harmful interference in which case the user will be required to correct the interference at his own expense.

EQUIPMENT MODIFICATION CAUTION: Equipment changes or modifications not expressly approved by Sensormatic Electronics Corporation, the party responsible for FCC compliance, could void the user's authority to operate the equipment and could create a hazardous condition.

WARRANTY DISCLAIMER: Sensormatic Electronics Corporation makes no representation or warranty with respect to the contents hereof and specifically disclaims any implied warranties of merchantability or fitness for any particular purpose. Further, Sensormatic Electronics Corporation reserves the right to revise this publication and make changes from time to time in the content hereof without obligation of Sensormatic Electronics Corporation to notify any person of such revision or changes.

LIMITED RIGHTS NOTICE: For units of the Department of Defense, all documentation and manuals were developed at private expense and no part of it was developed using Government Funds. The restrictions governing the use and disclosure of technical data marked with this legend are set forth in the definition of "limited rights" in paragraph (a) (15) of the clause of DFARS 252.227.7013. Unpublished - rights reserved under the Copyright Laws of the United States.

COPYRIGHT NOTICE: *SpeedDome* and *American Dynamics* are registered trademarks of Sensormatic Electronics Corporation. Other product names (if any) mentioned herein may be trademarks or registered trademarks of Sensormatic or other companies.

No part of this guide may be reproduced in any form without written permission from Sensormatic Electronics Corporation.

RLJ/CSD 04/2006