

Installation Guide

Installing the RHPLA Plenum Adapter

This procedure explains how to attach the plenum adapter to the top hat housing assembly, enabling the RHUITH Top Hat Housing to be mounted in plenum environments.

Tools Required

Scissors or knife
Adjustable wrench
5.5 mm (7/32") socket

Required Parts

01RHUITH Top Hat Housing

a) Housing, top hat 1 0500-7455-01

01RHPLA Plenum Adapter Kit

b) Nut, Connector 1 6010-0094-01
c) Conn, 1/2" NPT, I25-.38 cord, ST, Z 1 6010-0097-01
d) Plate, adapter plenum 1 0500-7923-01
e) Nut, lock, M3 SS304, P, 985 2 5826-0200-020
f) Washer, Fl Std, M3, SS304, P, 125A 2 5840-0200-020
g) Tape, Aluminum foil, 2" wide .5ft 3200-0331-01

Procedure

Note: Letters in brackets [] and in figures refer to items in kit.

1. Attach connector to adapter plate (Figure 1).

Remove nut [b] from connector [c], insert connector into adapter plate [d], and tighten nut securely. Insert connector into large hole, from flat side, opposite plate's two threaded studs.

Figure 1.

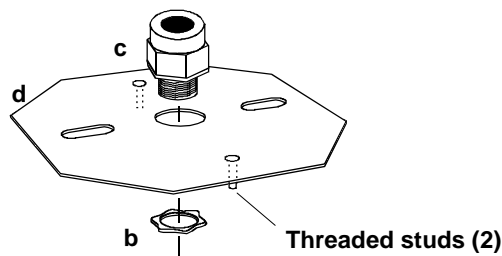

2. Prepare connector (Figure 2).

- Unscrew connector's knurled cover and remove seal washer and seal plug.
- Using knife or scissors, cut one side of seal plug so it can be spread open to go around cable.
- Pass composite cable through connector cover and body. Provide approximately 45cm (1.5') of cable below plenum adapter assembly.
- Spread seal plug and seal washer and place them around the cable, between connector cover and body.
- Press seal plug into connector body and tighten cover down over seal washer, seal plug, and body. Hand-tighten to create seal around cable.

Figure 2.

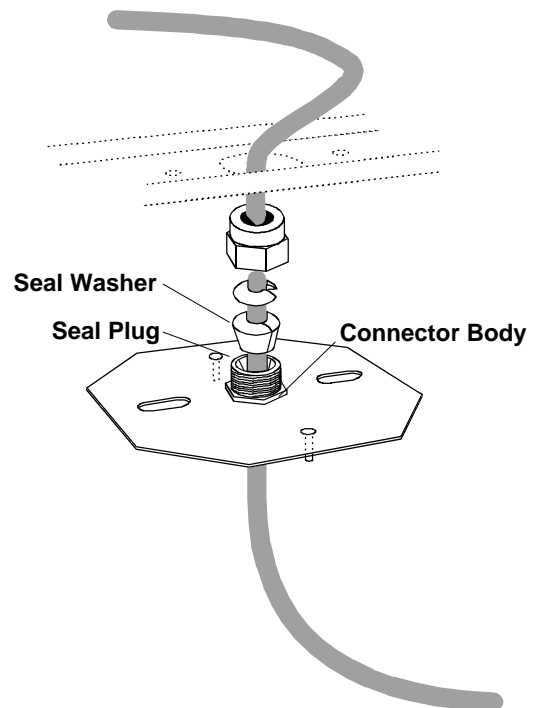

3. Attach plate to top hat (Figure 3).

- a. Run cable through large hole in top hat.
- b. Align adapter plate's two threaded studs so they can enter thinner slots in top hat. Press plate down onto top hat.
- c. Secure plate to top hat by placing M3 washer [e] and nut [d] over each threaded stud. Before tightening fully, align plate on top hat so two mounting slots are open.

Figure 3.

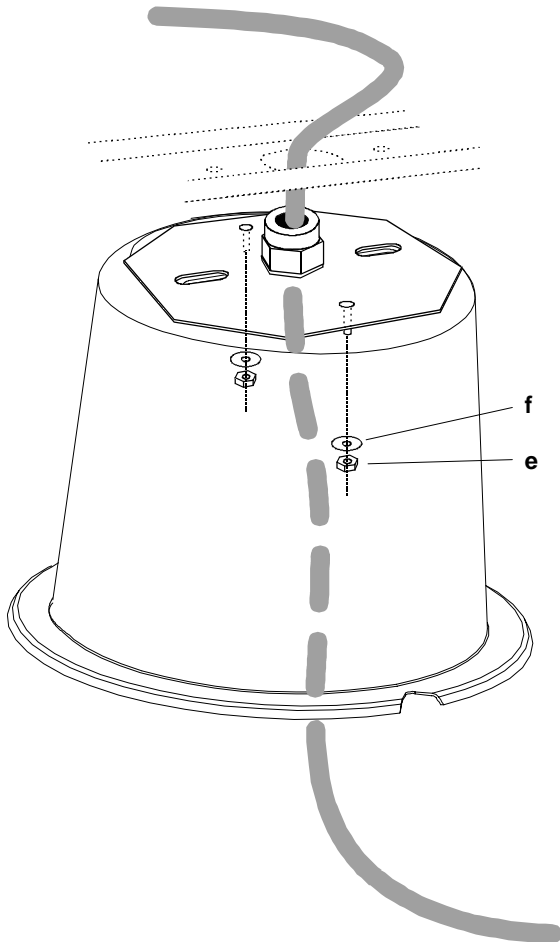

5. Attach top hat to 2x2 or 2x4 mounting structures, or to hard ceiling mount bracket (Figure 4).

- a. Use open slots to mount assembly to mounting structure.
- b. Completely tighten assembly to structure, assuring an effective plenum seal. As you tighten assembly, ensure connector fits through large hole in structure.
- c. Seal unused or open mounting holes with aluminum tape supplied in kit.

Figure 4.

