

# RJ855AP One-Position Outdoor J-Box Installation

## Features

- Supports one indoor or outdoor dome.
- Provides data "fan out" to additional J-Boxes.
- Weather-resistant, lockable metal case - mounts indoors or out.
- On/off switch.
- User-replaceable fuses.
- 115/230 Vac (50/60 Hz), 150W max.
- Operating temperature range: -40° to 50°C.

## Placement Considerations

- Mount J-Box vertically and within 25 cable-feet of outdoor dome.
- Mount J-Box such that on/off switch and fuses can be accessed.
- Use dedicated, unswitched (24 hour) AC power, supplied in accordance with local requirements.
- Provide good grounding for safety and transient protection.
- J-Box can be mounted to a wall or pole, in accordance with local requirements. For wall mounting, SEC supplies 4 toggle and 4 quick bolts (drill 1/4-inch holes for quick bolts). For pole mounting, use clamp package provided with dome to band J-Box to pole.
- Although the J-Box is designed for outdoor mounting, minimizing the exposure to environmental extremes is desirable. Outside, a sheltered area under a roof overhang is an ideal location whenever possible.

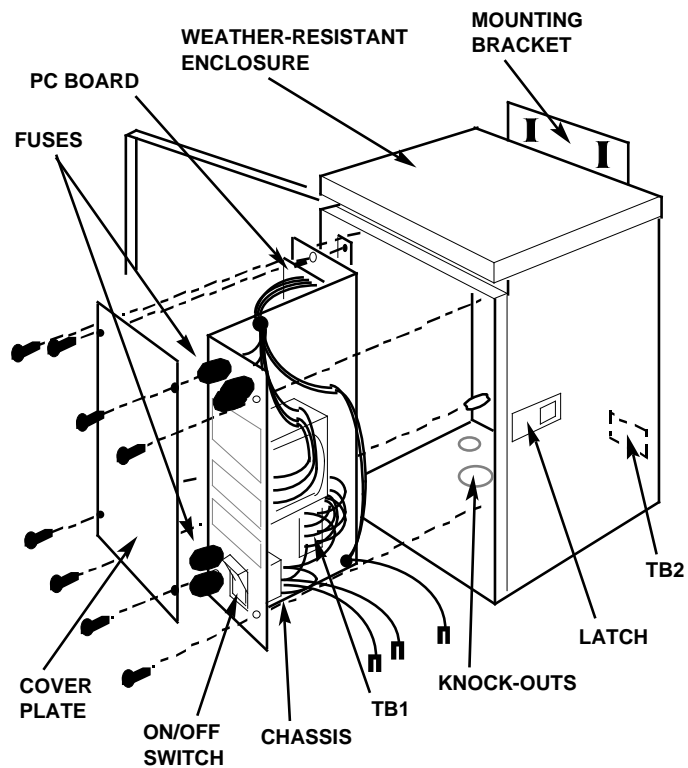

**WARNING: ALWAYS MOUNT VERTICALLY.  
DO NOT PIERCE ENCLOSURE.**

## Power Connections

Remove cover plate and chassis to access TB2 connector at rear of enclosure. Then connect the incoming AC wires to the TB2 connector as shown for 115 Vac or optional 230 Vac operation.

**IMPORTANT: 230 VAC OPERATION REQUIRES CHASSIS FUSE AND JUMPER CHANGES - SEE CHASSIS LABELS FOR DETAILS.**

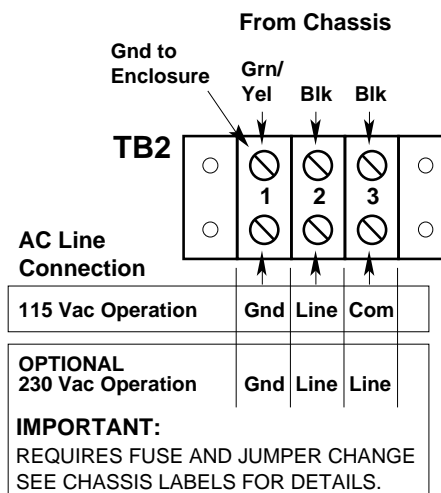

## RJ855AP One-Position Outdoor J-Box

### PC Board Connections

**IMPORTANT:** Cables exposed to the outdoor environment are subject to high energy transients that can couple into adjacent cables. Only TB1 and J2 have outdoor transient protection. To avoid possible damage to unprotected equipment, isolate these cables as much as possible. If data line transient protectors must be installed, install them at the data source (Controller or J-Box).

SIGNAL DESCRIPTION	CONNECT TO:	NOTES:
"Data Out (Ring)" from Controller "Data Out (Tip)" from Controller "Data In (Ring)" to Controller "Data In (Tip)" to Controller	TB1-1 DATA IN HI (Ring) 2 DATA IN LOW (Tip) 3 DATA OUT HI (Ring) 4 DATA OUT LOW (Tip)	<b>WARNING: Install data line transient protectors to all lines at the data source (Controller or J-Box) if these lines are routed outdoors.</b>
Composite Cable	J2 DOME POWER & DATA	<b>WARNING: Insulate or tywrap video connection to prevent contact with PCB.</b>
<b>AUXILIARY DATA 1</b> Data In Hi (Ring) from next J-Box Data In Lo (Tip) from next J-Box Data Out Hi (Ring) from next J-Box Data Out Lo (Tip) from next J-Box	TB2-3 AUX OUT 1 HI (Ring) 4 AUX OUT 1 LO (Tip) 8 AUX IN 1 HI (Ring) 9 AUX IN 1 LO (Tip)	<b>WARNING: Auxiliary data lines connected to TB2 require data line protectors if these lines are to be routed outdoors.</b>
<b>AUXILIARY DATA 2</b> Data In Hi (Ring) from next J-Box Data In Lo (Tip) from next J-Box Data Out Hi (Ring) from next J-Box Data Out Lo (Tip) from next J-Box	TB2-1 AUX OUT 2 HI (Ring) 2 AUX OUT 2 LO (Tip) 6 AUX IN 2 HI (Ring) 7 AUX IN 2 LO (Tip)	

---

### Testing the System

**To Test Data Going Into J-Box:** Press and hold S1 (data test switch) located in center of PC board. DS1 (LED) adjacent to switch should be green with its center flashing red constantly (good data).

**To Test Data Out of J-Box:** Insert Cinch-Jones Data Tester (PN 9TOL-6152-01) into J2 and press and hold S1 (data test switch). DS1 (data into J-Box) and DS2 (data out of J-Box) LED's along with LED inside of Data Tester (data out to dome) should be green with its center flashing red constantly (good data).

**To Test Data From Domes:** During normal operation depress and hold S1 (data test switch). DS1 (data to J-Box) will be green and flash red constantly as the controller "polls" each dome for proper status. DS2 (data out of J-box) will flash red once for each dome that answers through this J-Box. A polling sequence takes 13 seconds (23 seconds for System 58) to check all dome addresses and therefore it could take that long for DS2 to flash red if only one dome is connected through this J-Box.