

## SensorNet to RS-422 Converter

RCSN422

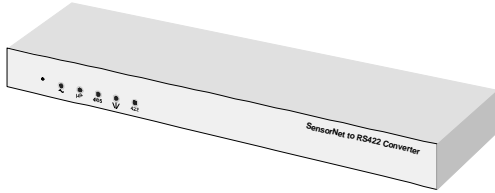

### Contents

About this Guide .....	1
About the SensorNet to RS-422 Converter .....	2
Dome Features Supported .....	2
Operating Limitations .....	2
Identifying Dome Types and Versions .....	3
Operating Differences Among Controllers .....	3
Declarations.....	4

### About this Guide

This user's guide explains the use of the SensorNet to RS-422 Converter with the View Manager® 16 Plus or View Manager 32 system. Other related documents are:

- View Manager 16 Plus System Operator's Manual, 8000-1009-01
- View Manager 32 System Operator's Manual, 8000-1673-01

This user's guide supplements the information available in your system operator's manual. Keep all documents related to operating your system together.

### If you need assistance...

Call your sales representative.

---

*View Manager* and *SpeedDome* are trademarks of Sensormatic Electronics Corporation. Other product names (if any) mentioned herein may be trademarks or registered trademarks of other companies.

No part of this guide may be reproduced in any form without written permission from Sensormatic Electronics Corporation.

RLJ 02/2005

## About the SensorNet to RS-422 Converter

The SensorNet to RS-422 Converter permits you to use domes installed on a RS-422 network with either a VM16 Plus or VM32 system controller on a SensorNet network. It does this by converting commands issued by the controller into a format that is understood by the domes on the RS-422 network.

The following diagram illustrates typical components found in the installation.

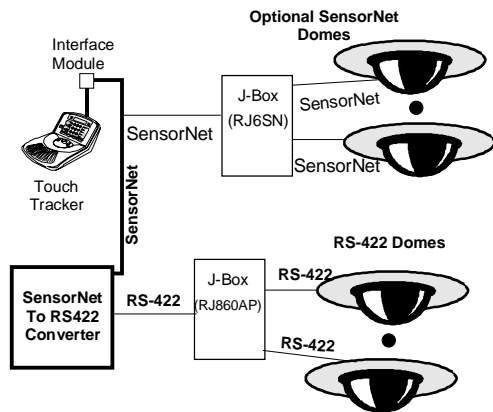

To simplify illustration, remote system and video switcher not shown.

**Note:** Product codes listed are for example purposes only.

**Figure 1:** Typical equipment installed with SensorNet to RS-422 converter.

Both RS-422 domes and SensorNet domes may be used with the controller when the converter is installed. All domes need to have unique addresses. The SensorNet domes are not affected operationally by the converter.

## Dome Features Supported

Depending on the types of domes installed at your facility, the features listed in the following table are supported. Refer to the Operating Limitations section for information about specific feature limitations.

Feature	Non-programmable	Mini-domes	SpeedDome®/SpeedDome Ultra Domes
Pan/Tilt	X	X	X
Proportional Pan/Tilt			X

Feature	Non-programmable	Mini-domes	SpeedDome®/SpeedDome Ultra Domes
Zoom, Focus, Iris	X	X	X
Flip			X
Apple Peel			X
View		X	X
Pattern		X	X
Repeat Pattern			X
Dome Reset			X
Vertical Phase Adjustment			X
Dome Info			X

For information about using these features, refer to your Operator's Manual. If programmable features are not working, re-select the camera and try the operation again.

## Operating Limitations

These limitations apply only to domes connected to the controller via the SensorNet to RS-422 converter.

1. Mini-domes do not support the Flip feature. The Touch Tracker will not beep to indicate this is an invalid selection.
2. The Peel button operates differently depending on the type of dome selected and what patterns have been programmed. For Mini-domes, if Pattern 3 has been programmed, pressing Peel causes Pattern 3 to run a single time. If Pattern 3 has not been programmed, no pattern runs. For SpeedDomes, if Pattern 3 has been programmed, pressing Peel causes Pattern 3 to run continuously. If Pattern 3 has not been programmed, the Apple Peel pattern runs continuously.
3. Programmable models of SpeedDomes and Mini-domes support four Views and three Patterns. Non-programmable versions of these and other domes do not support these features.  
The 96 Views feature available with SpeedDome Ultra III is not supported. A maximum of four Views is supported.
4. SpeedDome LT does not support Patterns. However, the auto pan feature is supported through Pattern 1.
5. Remote Vertical Phase adjustment, Proportional Pan/Tilt, and Info key functions only work with SpeedDomes,

including SpeedDome Ultra models. Domes without properly functioning return data communications operate with non-proportional control and without Views, Patterns, or the Info key features.

- The ability to update SpeedDome firmware through SensorNet communications is not available through this converter.

## Identifying Dome Types and Versions

To determine the dome type of a specific camera, select the camera and press the **Info** key on the Touch Tracker. The Touch Tracker's LCD displays a prefix of either "E" or "F" in front of the version number. The "E" prefix indicates that it applies to the dome's EEPROM version; the "F" prefix indicates that it applies to the dome's Flash version. Pressing the **Info** key alternates between displaying the Flash version and the EEPROM version.

Use the table below to identify the dome type. In this table, XXXX indicates the version number. For example, **F 0701-0006-0620** represents the SpeedDome Programmable (dual-card) Flash version 6.20.

Dome Type	EEPROM version	Flash Version
SpeedDome Ultra IV	0701-2507-XXXX	0701-2507-02XX or greater
SpeedDome Ultra III	0701-2507-XXXX	0701-2507-01XX
SpeedDome Ultra II	0701-9980-XXXX	0701-2315-03XX or greater
SpeedDome Ultra	0701-9980-XXXX	0701-2315-02XX or 0701-2315-01XX
SpeedDome Programmable (Unicard)	0701-0079-XXXX or 0701-0077-XXXX	0701-0081-XXXX
SpeedDome Programmable (Dual-Card)	0000-0000-0000	0701-0006-XXXX
SpeedDome Non-Programmable (Unicard)	0701-0079-XXXX	0701-0082-XXXX
SpeedDome Non-Programmable (Dual-Card)	0000-0000-0000	0701-0057-XXXX
SpeedDome LT	0701-2488-XXXX	0701-2489-XXXX

Dome Type	EEPROM version	Flash Version
MiniDome Programmable or earlier programmable dome	2222-2222-2222	2222-2222-2222
MiniDome Non-Programmable or earlier NP dome	1111-1111-1111	1111-1111-1111
SensorNet to RS422 Converter	0701-9070-XXXX	0701-2814-XXXX

**Note:** If both a dome and the code converter are assigned the same address, the information displayed on the Touch Tracker LCD relates to the code converter, not the dome.

## Operating Differences Among Controllers

As with any system, it may take some time to adjust to the feel of your VM16 Plus or VM32 system controller. Some features that you have been accustomed to using may not be supported or the implementation may have changed.

The following table compares the features available among the three systems.

Feature	VM1	VM16+	VM32
Sequence	X	X	X
Alarm Actions	X	X	X
Proportional speed control		X	X
Output Control		X	X
On-screen Forms	X		X
Alarm Clock / Timed Events	X		X
Time / Date	X		X
Camera Names	X		X
Alphanumeric keyboard	X		
Boundaries	X		
Zones	X		

**Sequence:** Both VM16 Plus and VM32 provide the ability to run sequences. VM16 Plus supports one sequence consisting of up to 16 events. VM32 supports two sequences (one for each installed Touch Tracker) consisting of up to 64 events.

**Alarm Actions:** Both VM16 Plus and VM32 support the ability to display a View, Pattern, or fixed shot in response to an alarm. Both systems can automatically initiate an output in response to an alarm. VM32 also provides the ability to assign which monitor video associated with the alarm will be seen.

**Proportional Speed Control:** For VM16 Plus and VM32, the speed of the camera movement is proportional to how far you move the pan/tilt control (called the Tracker Ball) from its center position. If you move the Tracker Ball slightly to the right, the camera will pan slowly to the right. As you move the Tracker Ball farther to the right, the camera's panning speed increases until it reaches its maximum speed. This is different from the VM1 system and may take some time and effort to adapt to; however, it provides better dome control.

This variable speed operation applies to SpeedDomes only. Other domes provide two speeds: normal and fast.

**Output Control:** Both VM16+ and VM32 support the ability to manually control dome outputs. In addition to dome outputs, VM32 supports the ability to control an additional output connected to the video matrix switcher.

**On-screen forms:** VM32 provides on-screen forms for setting system time and date, assigning camera names, scheduling timed events, and configuring monitor display information.

**Timed-Events:** VM32 provides timed-events to automatically run patterns, sequences, or views at specified times and on specified days. The timed-event *cannot* automatically initiate an output in response to an event.

### **Boundaries, Zones, and Alphanumeric**

**Keyboard:** Neither VM16 nor VM32 supports boundaries or zones. Neither the VM16 Plus nor VM32 Touch Tracker supplies an alphanumeric keyboard.

VM32 provides the ability to name cameras with alphanumeric characters via a special on-screen form. Refer to the VM32 System Operator's Manual for information related to using the on-screen form.

---

## Declarations

**FCC COMPLIANCE:** This equipment complies with Part 15 of the FCC rules for Class A digital devices when installed and used in accordance with the instruction manual. Following these rules provides reasonable protection against harmful interference from equipment operated in a commercial area. This equipment should not be installed in a residential area as it can radiate radio frequency energy that could interfere with radio communications, a situation the user would have to fix at their own expense.

**EQUIPMENT MODIFICATION CAUTION:** Equipment changes or modifications not expressly approved by Sensormatic Electronics Corporation, the party responsible for FCC compliance, could void the user's authority to operate the equipment and could create a hazardous condition.

### Other Declarations

**WARRANTY DISCLAIMER:** Sensormatic Electronics Corporation makes no representation or warranty with respect to the contents hereof and specifically disclaims any implied warranties of merchantability or fitness for any particular purpose. Further, Sensormatic Electronics Corporation reserves the right to revise this publication and make changes from time to time in the content hereof without obligation of Sensormatic Electronics Corporation to notify any person of such revision or changes.

**LIMITED RIGHTS NOTICE:** For units of the Department of Defense, all documentation and manuals were developed at private expense and no part of it was developed using Government Funds. The restrictions governing the use and disclosure of technical data marked with this legend are set forth in the definition of "limited rights" in paragraph (a) (15) of the clause of DFARS 252.227.7013. Unpublished - rights reserved under the Copyright Laws of the United States.