



SensorRail™ III E ADRL3TRK Series

SpeedDome® Ultra Programmable
Dome on a Rail

Installation Guide

CAUTION: Only a certified installer is authorized to install this equipment. Installation by anyone else will void the SensorRail warranty.

Contents

About this Guide	1
About the Product	1
Before You Begin	3
Installation Steps	5
1. Install Threaded Rods	5
2. Install PVC Holders	6
3. Install Stirrups, Eyebolts, and Jointing Plates	6
4. Install Rail Sections	7
5. Install Anti-Sway Cables	8
6. Insert Copper Tracks and Trolley Stop/Retrieval Tool	9
7. Install Optical Stop Labels	10
8. Install the PowerRail Module	11
9. Install the Camera Trolley	12
10. Attach Light Reducing Sections	13
11. Clean the Rail	13
12. Check Electrical Connections	13
13. Configure the System	14
14. Install the Cowling	15
15. Install End Covers	16
Ordering Parts	17
Specifications	20
Declarations	21
Appendix A: RF link DIP switch settings	32
Appendix B: Alternate RF antenna location	32
Appendix C: AD SensorRail Control Utility	33

About this Guide

This guide explains how to install the SensorRail III E system. It does not explain how to:

- Determine the exact mounting location of the rail. This is determined by the customer's needs and the site's ceiling structure.
- Program or operate the system. See *SensorRail III E User Guide 8200-0593-04* and *SpeedDome Ultra and AD Matrix User Guides*.
- Service the system. See Service Guide 8200-0593-03.

If you need assistance...

Contact your certified support representative.

About the Product

The SensorRail III E system enables a SpeedDome Ultra dome camera to transmit video as it moves along a rail to the ideal surveillance position.

The system consists of:

- 2.5m (8.2ft) rail sections (number determined by the total length of the rail) with installation hardware
- A light-reducing section at each end of the rail
- Ceiling suspension assembly, which includes M8 threaded rods, ceiling attachment hardware (not supplied), and mounting stirrups
- Copper tracks
- Camera trolley equipped with dome camera, RF transmit antenna, and motor
- PowerRail module that supplies dc power to the camera trolley, converts RS-422 data to RS-232 data used by the trolley, and receives the video signal from the dome camera
- Trolley stop and retrieval tool
- RF receive antenna.

IMPORTANT! At least two people are required to install this product safely and efficiently. Follow all procedures described in this guide explicitly. If installation difficulties occur, call:

American Dynamics Technical Services

Toll Free 800-507-6268, Option 2
International: 561-912-6259, Option 2

In Europe:

Technical Services at EMEA AD Technical Support
+800 CALL TYCO or (+800 22 55 8926)
From the UK: 08701 238 787
Direct: +31 475 352 722

Product Features

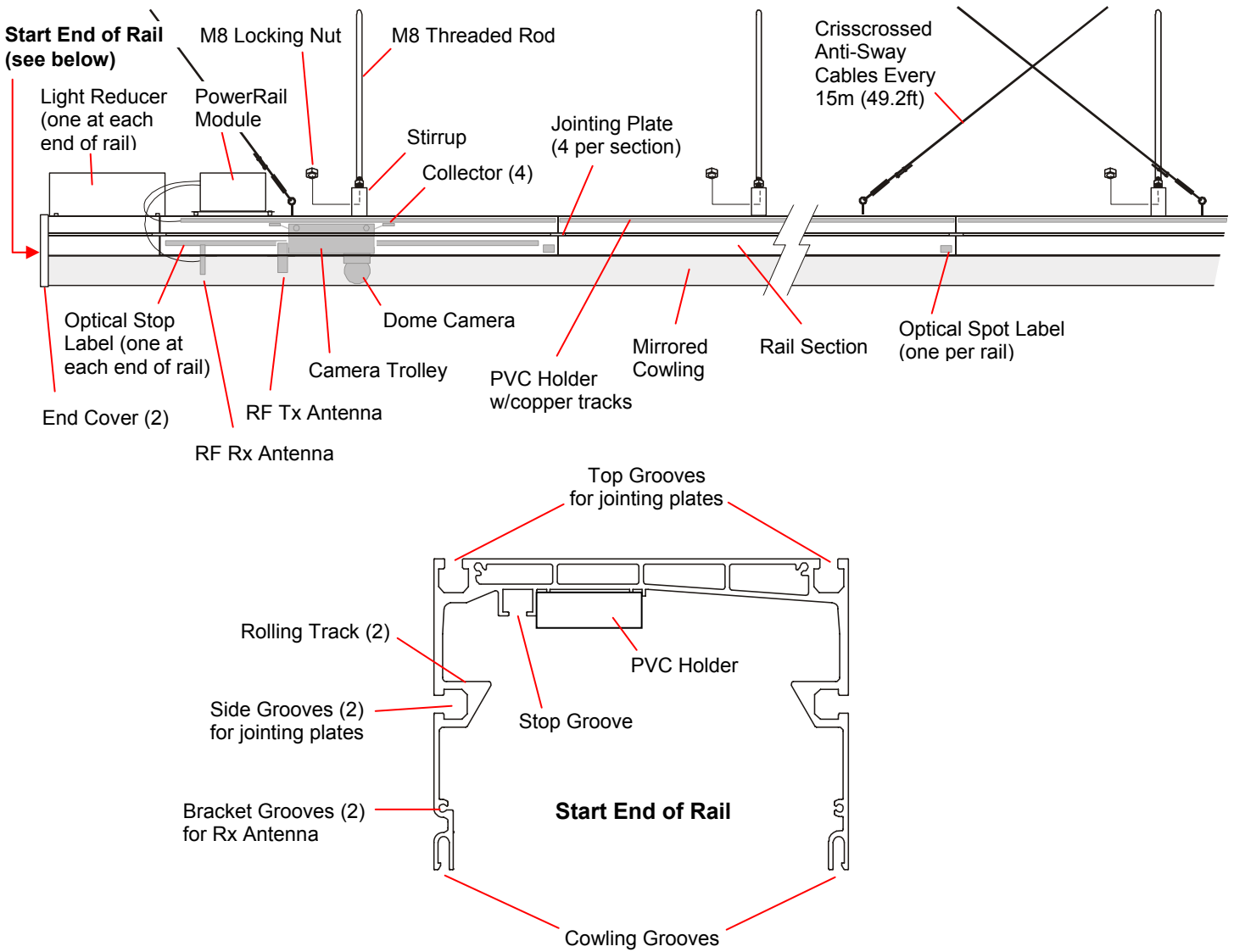

Vision area (for surveillance), dead zones (for stopping), and maintenance areas (for servicing)

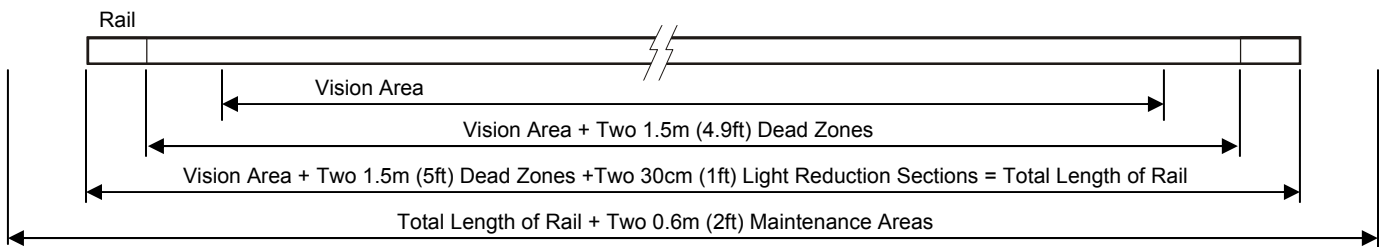

Before You Begin

IMPORTANT! Proper installation requires:

- Observing safety guidelines
- Analyzing the ceiling structure along the proposed rail route
- Considering space needed to service the rail
- Considering space needed to install the PowerRail module
- Considering distance to nearby lights to prevent them from silhouetting the camera location
- Determining the location of ceiling suspension assembly components, such as M8 threaded rods and anti-sway cables
- Knowing parts supplied, parts to be purchased, and tools and equipment required
- Understanding the installation process by reading procedures in this guide in detail before beginning installation.

Safety Guidelines

The rail system must conform with all applicable Standards or Codes of Practice pertaining to the country or state in which it is to be installed. Specifically:

- Certified electricians (in accordance with local regulations) must be used to install mains power cabling and termination.
- Licensed machinery operators must be used during installation of the system.
- A dedicated power circuit equipped with a 6A breaker and 30mA differential must be allocated to the system.
- Exposed and external cables must be placed in conduit or sheathed in cable wrap.

Ceiling Irregularities



CAUTION: DO NOT mount the rail directly to the ceiling. Irregular ceilings can distort the rail and damage it as the ceiling expands and contracts.

A Hilti MF C31/8 fast grip system and Hilti MQ-41 suspension bar (not supplied) may be required to attach the rail to ceiling red iron.

Acoustic Tile Ceilings



WARNING! DO NOT mount the rail structure directly to an acoustic tile ceiling; it cannot support the weight. Instead, extend threaded rods through the tile to a rigid ceiling structure capable of supporting the weight.

Space Requirements

Allow at least:

- **60cm (24in)** from the ends of the rail to vertical surfaces, such as walls to enable the camera trolley to be removed and serviced.
- **50cm (20in)** of vertical space above the rail to install the PowerRail module.
- **23cm (9in)** from the rail to nearby lights
 - Because lights can silhouette the dome camera, making it visible to people below the rail, factor in the installation height of the rail to nearby lighting.
 - Ensure the gap between the rail and the lighting system is no more than 5cm (2in) to reduce artifacts inside the cowling.

IMPORTANT! Installing the rail perpendicular to a tube-type lighting system may cause more artifacts than when it is installed in parallel.

Lay Out the Structure on the Ground

Lay out the rail system on a piece of paper to identify ceiling obstacles along the route, lighting that can affect covert operation, and where to place the anti-sway cables.

Anti-Sway Cable Locations

To prevent the rail from swaying, two anti-sway cables angled out no more than 35° from vertical are installed at each end of the rail. Additionally:

- For rails 9.1m (30ft) or less, one crisscrossed anti-sway cable is installed at the center of the rail.
- For rails 9.1m (30ft) or more, anti-sway crisscrossed cables are installed vertical to the rail every 15m (49.2ft) as required.
- If the last two crisscrossed anti-sway cables cannot be separated by 15m (49.2ft), then reduce spacing between all crisscrossed cables to make them equidistant.

Parts Supplied

Note: The number of parts supplied depends on the length of the rail.

- Rail section package, which includes:
 - 2.5m (8.2ft) straight rail sections
 - 2.5m (8.2ft) PVC holders
 - Stirrups, 1 per rail section
 - Jointing plates, 4 per rail section
 - Screws for jointing plates.
- Rail accessories package, which includes:
 - End covers (2) with attachment hardware
 - Springs for service stop blocks (2)
 - Stop screws (2)
 - Nylon service blocks for mechanical stops and trolley retrieval (2)
 - Optical stop strip (1 roll)
- Light reduction kit
 - 30cm (11.8in) section w/top hat cover (2).
- Trolley package
 - Camera trolley with 2.4GHz RF transceiver, CPU, SpeedDome Ultra dome camera, and motor
 - PowerRail 90–240Vac (50/60Hz) to 27Vdc power supply with RS-422 to RS-232 connections, 2.4GHz receiver, PAL.
- Cowling package
- Copper tracks package
 - Wheels to hold copper tracks
 - Support structure for wheels
 - Service trolley
 - Steering wheel to retrieve copper tracks for servicing.

Note: The tool used to install copper tracks is not supplied with the system.

Parts to be Purchased Separately

- M8 threaded rods and related hardware, and ceiling connection assemblies
- 3.3mm (1/8in) cable (as needed), steel galvanized 7x19 strands, minimum working load limit 680kg (1500 lbs)
- 8mm (5/16in) galvanized eyebolts, 317kg (700 lbs) minimum working load limit
- U-bolt clamps and wire thimbles for 3.3mm (1/8in) cable
- 9.6mm (3/8in) minimum size diameter jaw & jaw turnbuckles, 544kg (1200 lbs) break strength, 362kg (800 lbs) minimum working load limit
- SensorNet-to-RS422 code converter for VM16, VM32 and MegaPower LT video controllers, if used. The AD1024 matrix switcher requires a 2083 converter.

Tools and Equipment Required

- Proper lift equipment (scissor lift with extended work platform is recommended)
- Hilti PR-15 rotating laser leveling device
- 60cm (2ft) bubble level
- String line
- Battery-powered drill, ½-inch
- Metric screwdrivers and Allen wrenches
- M13 open wrench
- 0.1–5mm feeler gauge set
- Common hand tools, such hammers, cutters, and pliers
- Copper track installation/retrieval tool
- Torque wrench
- Soldering iron
- Laptop with AD SensorRail Control application installed and a serial port or USB-to-serial port
- Protective gloves (surgical or cotton type)
- Protective eyewear
- Plastic card similar to a credit card
- Ruler
- Cleaning pads and tissues (for fingerprint removal upon completion).

Installation Steps

The following step numbers refer to pull-out drawings at the end of this document.



CAUTION: Perform all steps carefully and methodically. DO NOT skip steps!

1. Install threaded rods
2. Install PVC holders
3. Install stirrups, eyebolts, and jointing plates
4. Install rail sections
5. Install anti-sway cables
6. Insert copper tracks and trolley stop/retrieval tool
7. Install optical stop strips
8. Install PowerRail module
9. Install camera trolley (complete trolley stop/retrieval tool assembly)
10. Attach light reducing sections
11. Clean rail
12. Check electrical connections
13. Configure system
14. Install cowling
15. Install end covers.

Installation Requires a Laser Leveling Device

A Hilti PR-15 rotating laser leveling device is used to level the rail during installation. Set the beam to intersect with a prominent horizontal feature on the rail.



WARNING! Wear protective eyewear when using a laser leveling device. Refer to the device manufacturer's instructions for additional safety precautions.

1. Install Threaded Rods

Threaded rods secure the rail system to the ceiling. Each rod attaches to the ceiling using one of the following methods:

- Direct into the ceiling
- To red iron ceiling supports using a "fast grip" system such as a HILTI MF C31/8
- To a suspension bar such as a HILTI MQ-41 between red iron when ceiling supports are spaced more than 2.5m (8.2ft) apart.

The bottom of each rod attaches to a stirrup at the top of the rail section.

Tools, Equipment, and Parts Required for this Operation

- Proper lift equipment (scissor lift with extended work platform is recommended)
- Hilti PR-15 rotating laser leveling device
- String line
- M8 threaded rods (one per rail section)
- Saw (to cut rods)
- M8 nuts (one per rod).

Procedure

Note: Observe space requirements (page 3).

A. Run a string line.

- Centered along the rail route
 - 10cm (4in) higher than the top of the rail.
- Tack the string in place.

B. Install the first threaded rod.

Each rod supports a rail section at its center. Install the first rod 1.25m (5.1ft) from where the first 2.5m rail section is to start.

C. Install subsequent threaded rods.

From the first rod, install subsequent rods every 2.5m (8.2ft) along the string line to the point where the last rail section will be located.

D. Thread nuts.

On each rod, thread a nut up until its bottom touches the string line and 5cm (2in) of rod is below the nut.

E. Saw off any extra rod length beyond 5cm (2in). Do not use a cutter.

2. Install PVC Holders

PVC holders carry copper strips that the trolley uses to get power and send and receive data. These holders lie underneath the top surface of the rail.

IMPORTANT!

- Looking into the START END of the rail, notches for the PVC holder and the stop groove must be on the left side of the rail. See the figure on page 2 for these items.
- Each PVC holder has notch running along one side of it. Ensure the notch is adjacent to the stop groove in each rail.

Tools, Equipment, and Parts Required for this Operation

- PVC Holders (one per rail section)
- Saw to cut PVC holder
- M6 self-tapping screw.

Procedure

A. For first and last rail sections only.

- **Cut PVC holder.** Cut a PVC holder in half. Then cut one of the halves 5cm shorter than the other.
- **Insert half PVC holder that is 5cm shorter.** With the notch in the side of the PVC holder adjacent to the stop groove, insert the PVC holder into the rail until it is 5cm (2in) from the start end of the rail.
- **Install self-tapping screw.** Install a self-tapping screw 5cm (2in) from the start end of the rail (where shown) to prevent the trolley from shifting the PVC holder out of the rail.

B. For all other rail sections.

With the notch in the side of the PVC holder adjacent to the stop groove, slide the PVC holder halfway into the rail.

Note: The other half of the holder will remain outside the rail. This half will insert into the next rail section.

3. Install Stirrups, Eyebolts, and Jointing Plates

- A stirrup is required to mount each section to the threaded rod above.
- Four jointing plates are required to attach it to the previous rail section.
- Eyebolts are attached in pairs to the top grooves in the overall rail to attach “anti-sway” cables, as required.

Tools, Equipment, and Parts Required for this Operation

- 2.5m (8.2ft) rail sections
- Stirrup (one per rail section)
- Eyebolts for stabilization cables (as required)
- Jointing plate and associated hardware (four per rail section).

Procedure

A. Install stirrups.

Slide a stirrup along grooves in the top of the each rail section until it reaches the middle of the section.



CAUTION: Pull and wiggle the stirrup to ensure it does not come out. If it does, replace the stirrup, and send the defective stirrup to Technical Support.

B. Install eyebolts for anti-sway cables.

Thread nuts on cable eyebolts. Then slide a pair of eyebolt/nut assemblies into grooves in the top of the appropriate rail sections, and move them to positions determined for anti-sway cables during planning (see “Anti-Sway Cable Locations” on page 3). Tighten eyebolts to secure them in place.

C. Prepare jointing plates (four per rail section).

Install the two large Allen screws in the outside holes. Install the two smaller Allen screws in the inside holes.

D. Install jointing plates.

1. Slide one of the four plates halfway into the outer grooves of each rail section, and hand-tighten its outside screw against the rail.
2. Slide the remaining plates all the way into their grooves. Keep them loose.

4. Install Rail Sections

Rail sections connect end-to-end to create the camera route. Repeat this procedure for each rail section until the total rail is complete, as straight as possible, and uniformly butted.

Note:

- The rail should look straight, but does not have to be precisely straight.
- TAKE YOUR TIME aligning rail segments. Cumulative misalignment can cause a noticeable curve in the rail.
- A single rail section attached to a threaded rod will sway, making subsequent rail installation difficult. Therefore, for ease of installation, the first two rail sections are joined on the ground BEFORE they are attached to the rods.

Tools, Equipment, and Parts Required for this Operation

- Proper lift equipment (scissor lift with extended work platform is recommended)
- Hilti PR-15 rotating laser leveling device
- 2.5m rail sections required to complete rail
- M8 locking nuts (one per rail section).

Procedure

A. Join two rail sections on the ground.

1. Uniformly butt the rail sections together by sliding the mating groove of one section over the protruding jointing plate of the other. There should be no space between the two sections. Also, each exposed PVC holder should insert into the adjacent rail section.
2. Center the loose jointing plates over the joint and hand-tighten the outside screws of all plates.

B. Attach the rail sections to the threaded rods.

1. Using the scissor lift, raise the sections until the rods just touch the holes of each stirrup.
2. CAREFULLY raise sections further until the rods enter the holes in the stirrups and the top of the stirrups are butted against the nuts on the rods.
3. Secure each rail section to the rod using a Nylon stop nut. DO NOT tighten the nut.

C. Level the rail sections.

1. Level sections by adjusting the two center screws in the top jointing plates.
2. At the joint, check the top surface of the rolling track within the rail for misalignment that can cause the camera trolley to vibrate.
3. Once leveled, tighten the stop nuts under the stirrups.

D. Straighten the rail sections.

1. Place the laser leveling device in horizontal mode, and run the beam along the rail.
2. Measure the gap between the beam and the side of the rail; it should not be more than 1cm (0.4in). If the gap is greater than 1cm, repeat step C.

BE CAREFUL. Maximum joint gap cannot exceed 0.4mm (0.016in). Use a feeler gauge to verify.

3. If necessary, straighten sections by adjusting the two center screws in the side jointing plates.

Note:

- The rail should look as straight as possible, but does not have to be precisely straight. However, how straight and level the sections are IS IMPORTANT because they determine how straight the finished rail will be.
- Despite efforts, the rail can bend up to 10cm (4in) from one end to the other due to the cutting tolerance of the aluminum (0.2mm).

E. Attach each subsequent 2.5m rail section to the rail.

1. Using the scissor lift, raise the next rail until it aligns with the previous section and the top of the stirrup is against the nut on the rod.
2. Repeat steps B–D.

5. Install Anti-Sway Cables

The single row of threaded rods can cause the rail to potentially swing. To prevent this:

- Install two anti-sway cables at each end of the rail.



CAUTION:

- Locate landing points in the ceiling structure that do not allow the cable to angle more than 35° from vertical in any direction.
 - Cables must meet all safety and regulatory guidelines.
- Install crisscrossed cables as determined during the planning stage (see page 3).

Tools, Equipment, and Parts Required for this Operation

- Proper lift equipment (scissor lift with extended work platform is recommended)
- Unistrut I-beam clamps rated for 294.8kg (650 lbs) using 5/16in rod or M8
- 3.3mm (1/8in) cable, steel galvanized 7x19 strands, 680kg (1500 lbs) minimum working load limit
- 8mm (5/16in) diameter galvanized eyebolts; shoulder lifting eyes smaller length threads, 317kg (700 lbs) minimum working load limit
- U-bolt clamps, wire thimbles for 1/8-inch cable
- 9.6mm (3/8in) diameter jaw & jaw turnbuckles; 544kg (1200 lbs) break strength, 362kg (800 lbs) working load limit.

Procedure

At the ceiling:

- A. Install I-beam clamps on the side of the beam opposite the cable pull direction.**
- B. Thread an eyebolt into the beam clamp where the rod would normally go.**
- C. Insert a cable thimble into each eyebolt.**
- D. Loop the cable around the thimble and secure it using two U-bolts.**



CAUTION: Note the right way to secure the cable for maximum strength. Minimum cable turnback is 82mm (3.25in).

At the rail:

- E. Attach a turnbuckle to each eyebolt.**
- F. Insert a cable thimble into the unused jaw of each turnbuckle.**
- G. Loop each cable around its respective thimble and secure it using two U-bolts.**



CAUTION: Note the right way to secure the cable for maximum strength. Minimum cable turnback is 82mm (3.25in).

Ensure cables are taut by tightening each turnbuckle to 1.4–2kg-meters (3–4.5ft-lbs) with a torque wrench.

6. Insert Copper Tracks and Trolley Stop/Retrieval Tool

Four copper tracks feed 27Vdc power and RS-232 data to the camera trolley. A track installation/retrieval tool (supplied separately) is used to insert copper tracks and can be used to retrieve copper tracks for servicing.

Note: During this step, a trolley stop/retrieval assembly is inserted and pulled into position.



CAUTION: Ensure copper tracks are not bent or wavy when they are inserted into the PVC holder. Bends or waves make installation difficult and will affect operation of the camera trolley.

Tools and Equipment Required for this Operation

- Cutter, pliers
- Copper track
- Soldering iron
- Track installation/retrieval tool (supplied separately)
- Trolley stop/retrieval assembly consisting of 1 service block, 1 spring, 1 M8 screw with nut, and strapping tape.

Procedure

A. Install a spring and screw into the stop groove at the end of the rail.

Insert the spring into the end of the rail. Then thread an M8 nut on the screw. Install the screw 5cm (2in) from the end of the rail and tighten.

B. Attach strapping tape to a service block and insert it into the stop groove at the start end of the rail.

1. Fold the strapping tape 1.9cm (.75in) back on itself. Then make a small hole in the folded section using a soldering iron.



CAUTION: DO NOT punch a hole in the tape; the material will break! Use a soldering iron instead.

2. Remove the M3 screw from the service block, and insert it through the hole in the folded section of tape and into the block.
3. Tighten the screw to secure the tape.
4. Insert the service block with the tape attached. Ensure the tape faces the start end of the rail.

C. Insert the service trolley “handle first” into the rail.

D. Assemble the reel that holds the rolls of copper track.

1. Lay out the five supplied wheels on the ground and insert six screws in one of the wheels.
2. Place a copper roll on the wheel with the six screws; then place another wheel on top of the roll.



CAUTION: To prevent the copper strip from unraveling from the roll, DO NOT remove the tie wrap until roll is clamped between two wheels.

3. Repeat step 2 above for the next three rolls. Use the fifth wheel and five bolts supplied to clamp all the wheels together.
5. Bolt left and right axles to the wheels using six bolts per axle. Ends of axles are marked “L” for left and “R” for right.

E. Assemble the support structure that holds the copper reel.

F. Insert the support structure into the starting end of the rail.

Insert the structure into the grooves in the side of the rail, and tighten it in place using the four screws.

G. Place the copper reel onto the support structure.

Place the left and right axles of the wheel assembly into the slots of the support structure and lock the axles in place. Looking into the beginning of the rail, the left axle faces left.

H. Insert the copper track, and pull the tape to the end of the rail.

1. Insert each copper strip into its respective slot in the PVC holder.
2. Roll the service trolley over to the strips until its four pins align with grab holes in the copper tracks. Then shift the pins up against the PVC and tighten them in place using the two screws on the side of the trolley.
3. Temporarily insert the second service block—slit first—into the stop groove to hold the tape in place at the start end of the rail.

4. Pull the trolley along the entire rail until the trolley and copper tracks exit the other end of the rail.

IMPORTANT! While pulling the service trolley, hand push the service block with the tape attached to where it touches the spring at the end of the rail. Remember, the tape must face the start of the rail.

5. Detach the copper tracks from the trolley.
6. Cut the tape approximately 50cm (19.7in) beyond the rail. This excess will be used as a pull to manually retrieve the trolley if control of the trolley is lost.

Note: DO NOT pull the tape; it can move the stop block at the other end of the rail.

I. Bend excess copper at both ends of the rail.

1. Cut off excess track leaving 2cm (.8in) of copper track out of the PVC holder at the START and END of the rail.
2. At the start end of the rail, bend excess copper track over the PVC holder to make an "S" shape that will be used to connect power and data crimp connectors.



WARNING! Ensure copper tracks do not touch each other or any part of the aluminum structure.

J. At the end of the rail, bend the excess copper track over the PVC holder.

K. Remove the copper track installation/retrieval tool from the rail.

7. Install Optical Stop Labels

Optical stop labels affix inside the rail nearest the PVC holder to enable the trolley to recognize the beginning and end of its route.



WARNING! Beginning and end optical stop label locations are different. Incorrect label application can cause a hazardous situation.



WARNING! Stop labels are made of special tape that enables the optical sensor in the trolley to work. Do not use any other tape.

Tools, Equipment, and Parts Required for this Operation

- Proper lift equipment (scissor lift with extended work platform is recommended)
- Roll of label tape (1) cut into three equal 2.5m pieces.

Procedure

A. Affix the beginning stop label.

1. Cut 10cm (3.9in) from the length of the beginning stop label.
2. Place this label above and adjacent to the raised line in the first rail section.

Note: Keep the end of the label flush with the start end of the rail. The other end of the label should end 5cm (12.7in) from the spot label.

B. Affix the two end stop labels.

These labels must:

- Be affixed adjacent to the raised line in the last rail section; one above the line, the other below it.
- Overlap the last rail junction by 3mm.

C. Remove the spot label ONLY from the last rail section.

Note: A spot label is applied during manufacture at the end of each rail. If a spot label is missing or improperly placed on any of the rails, call Technical Support to report the problem. Meanwhile, cut a new spot label the same size as the old one from the roll of label tape. Place the new label where the old one should be.

8. Install the PowerRail Module

The PowerRail module:

- Converts RS-422 signals from the video controller to RS-232 signals.
- Sends and receives RS-232 signals from the camera trolley
- Receives video from the camera trolley and sends it to the video controller for display on a monitor.

The module mounts to the top of the first rail section.

Tools, Equipment, and Parts Required for this Operation

- Proper lift equipment (scissor lift with extended work platform is recommended)
- PowerRail module
- Power, data, and RF antenna cables
- Crimp connectors.

Procedure

A. Bolt the module to the rail.

45cm (17.7in) from the start end of the rail, secure the module to the top of the rail using four plastic screws, washers and M8 nuts installed in the top grooves of the rail. Ensure the RF cable from the module reaches the intended antenna mounting site within the rail.

B. Connect power from the module to the rail.

Attach one end of the 27Vdc and ground wires to the module, and crimp their other end to the rail. Ensure wires are long enough to reach the copper tracks without stretching.

C. Connect data from the module to the rail.

Attach one end of the Tx (RS-232 data) and Rx (RS-232 data) wires to the module and crimp their other end to the rail. Ensure wires are long enough to reach the copper tracks without stretching.

D. Connect RS-422 data from the video controller to the module.

Matrix RS-422		PowerRail RS-422
TX+	goes to	RX+
TX-	goes to	RX-
RX+	goes to	TX+
RX-	goes to	TX-

E. Connect the RF antenna cable.

Connect the SMA cable to the PowerRail module; and then run the cable from the PowerRail module to the location for the RF receiving antenna.

F. Connect AC to the module.

Have a certified electrician connect the PowerRail module to the ac power source. Ensure the power switch on the module is in the off position.

9. Install the Camera Trolley

As the camera trolley moves along the rail, it transmits video and camera data to the PowerRail module, which sends them to a monitor via a video controller. Four sliding collectors on the trolley transfer power and data to the rail.

Note: The four sliding collectors compensate for linearity differences that may occur along the rail. Two sliding collectors are at each end of the trolley.

Tools, Equipment, and Parts Required for this Operation

- Proper lift equipment (scissor lift with extended work platform is recommended)
- Camera trolley
- Bracket and associated hardware for RF receiving antenna
- Attenuator for the RF transmitting antenna
- RF receiving antenna.

Procedure

A. Prepare the dome camera.

1. Detach the dome camera from the trolley, but do not detach the cables.
2. Gently remove the lens from the dome camera's slot cover.
 - a. Gently swivel the eyeball of the dome camera to totally expose one of two slot covers.
3. The camera's address is preset to "1". Set the required address for the rail.
4. Insert the dome back into the mounting base, and twist it to lock it in place.



CAUTION: Swiveling fast can damage gears.

- b. Insert a small, thin-bladed screwdriver into the space between the cover and the eyeball.
- c. Gently pry off the slot cover containing the lens.
- d. Pop the lens from the slot cover, and snap the cover back onto the eyeball.

IMPORTANT! Ensure wires are not caught in the latching mechanism before locking the dome in place.

B. Remove the service block at the start end of the rail holding the tape in place and slide the camera trolley onto the rail.

With its antenna facing the starting end of the rail, carefully insert the trolley wheels onto the rolling track, and roll the trolley about 1m (3.3ft) down the rail.

C. Install the RF receiving antenna.

1. Insert the plastic bracket supplied with the antenna into the rail where shown and about 15cm (6in) from the start end.

Note: To enable transmit and receive antennas to align with each other, bracket holes used to mount the antenna must be closer to the left side of the rail when viewed from the start end.

2. Attach the RF receiving antenna to the plastic bracket using two screws. Align the antenna so it is directly facing the receiving antenna on the trolley.
3. An RF attenuator matched to the rail length is attached to the transmitting antenna. If the rail length is different, change the RF attenuator according to the table below.



CAUTION: The attenuator is required to comply with the CE regulation.

Rail Distance	RF Attenuator
10–45m	30dB
50–75m	20dB
75–100m	10dB or 15dB

4. Connect the SMA cable from the PowerRail module to the antenna.

D. Install the trolley stop assembly.

1. Thread two M8 nuts onto the stop screw.
2. At the start end of the rail, slip the second service block, a spring, and a stop screw (with nuts) into the stop groove and under the strapping tape.
3. With the stop screw 5cm (2in) from the start of the rail and its tip 3mm (0.12in) from the top of the groove, tighten the stop screw.
4. Ensure that each block is lightly pushing the spring against the stop screw, and the strapping tape exits 50cm (19.7in) beyond the rail.

10. Attach Light Reducing Sections

Light reducing sections are not used by the camera trolley, but rather to reduce light that can enter the cowling from the ends of the rail. A light reducing section attaches to each end of the rail.

Tools, Equipment, and Parts Required for this Operation

- Proper lift equipment (scissor lift with extended work platform is recommended)
- 30cm (11.8in) light reducing section with top hat (2).

Procedure

A. Join a light reducing section to the start of the rail.

1. To allow for installation of the end covers, the top hat must be shifted so it lies slightly over the first rail section. To facilitate this—in the top jointing plates—insert the small Allen screws into the large Allen screw holes that lie over the light reducing section and place the two large Allen screws aside for later use.
2. Uniformly butt a light reducing section to the rail by sliding the mating groove of that section over the protruding jointing plate. No space should be between the two sections.
3. Center the jointing plates over the joint and hand-tighten the outside screws of all plates.
4. Secure the top hat to the light reducing section by inserting screws and nuts through holes in the top hat flange that faces the end of the rail, and use the two large Allen screws to secure the other end of the top hat to the two top jointing plates.
5. Tuck any excess tape into the space within the light reducing section at the start end of the rail.

B. Repeat step A to attach the other light reducing section to the end of the rail.

11. Clean the Rail

The rail is sensitive to fingerprints. To clean the rail, use a tissue soaked with window glass cleaner or use a window glass cleaning pad.

12. Check Electrical Connections

Ensure electrical connections from the PowerRail module to the track and antenna are correct. Verify that the copper tracks do not touch each other at the ends of the rail or touch the structure.

13. Configure the System

Equipment Required for this Operation

- Laptop
- AD SensorRail Control application.

Procedure

A. Power up the rail.

Flip the main switch located on the PowerRail module. The trolley will move approximately 3m (9.8ft) down the rail, and then back to the home position approximately 1m (3.3ft) inside the optical stops.

Note: If the trolley does not move, check the electrical connections.

B. Configure the system.

Note: Depending on the trolley configuration, movement along the rail is achieved using IRIS or FOCUS keys on the Touch Tracker® controller or AD Keyboard. For example:

- Press on IRIS open (or FOCUS near) to move the trolley forward.
- Press on IRIS close (or FOCUS far) to move the trolley backward.

The Dome AUTO-FOCUS mode is still available (by simultaneously pressing IRIS close and IRIS open).

IMPORTANT! The dome camera's movement along the rail prevents the following features from working effectively:

- Privacy zones
- Direction indicators
- Freeze frame
- Home position.

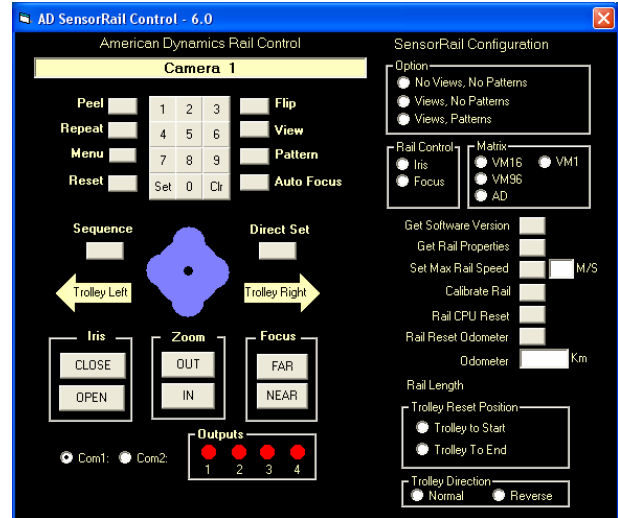

On your laptop computer, use the AD SensorRail Control configurator screen (shown above) to test the trolley and dome camera functions. Also, check the entire rail for joint alignment.

To initiate the trolley for the first time:

1. Connect a DB25 to DB9 communication cable between the laptop and the PowerRail module. A standard crossed serial cable, wired as shown, is required (see figure on page 31).
2. In the Power Rail module, move jumpers ST3 and ST4 to the PC position (see figure on page 31).
3. Launch the configurator application. When the configurator screen appears, select the dome camera address, and then press SET. For example, if the dome address for the trolley is 9, all commands will go to dome 9.
4. Click the CALIBRATE RAIL button on the configurator to have the trolley learn the rail length.
5. Using the configurator and a portable video monitor, move the trolley along the rail to expose possible issues, such as poor video or trolley homing.

Note: If RF interference is causing video problems, try an alternate DIP switch selection on the PowerRail. See Appendix A.

Note: If RF holes are causing video problems, adjust the receiving antenna's angle and inner position for the best compromise. If RF holes still exist, try attaching the antenna externally to the start end of the rail using the extension brackets supplied. See Appendix B.

- Note the trolley mileage by doubleclicking the Output 2 LED at the bottom of the screen. The monitor temporarily displays the software version and mileage in kilometers.

Note: Ensure rail calibration displays the correct rail length in meters. If not, repeat this step. If the rail length is still not correct, ensure the spot LED on the trolley circuit board lights every time it passes a spot label. If the LED does not light, clean the optical encoders on the circuit board, and if this does not work, call Technical Support.

- In the Matrix section, select the matrix switcher to be used by clicking the appropriate choice.
- In the Rail Control section, select the controller or keyboard key that will control the trolley by clicking "Iris" or "Focus".
- Check all functions (especially presets and patterns management if validated during installation).
- Check optical stop detection (see CAUTION below). The dome can be oriented to see the function LEDs on the CPU board.



CAUTION: Do not run the trolley at full speed in case of detection failure.

- Check the RS-422 data in and out LEDs on the trolley CPU board. These LED's can be seen from the dome.

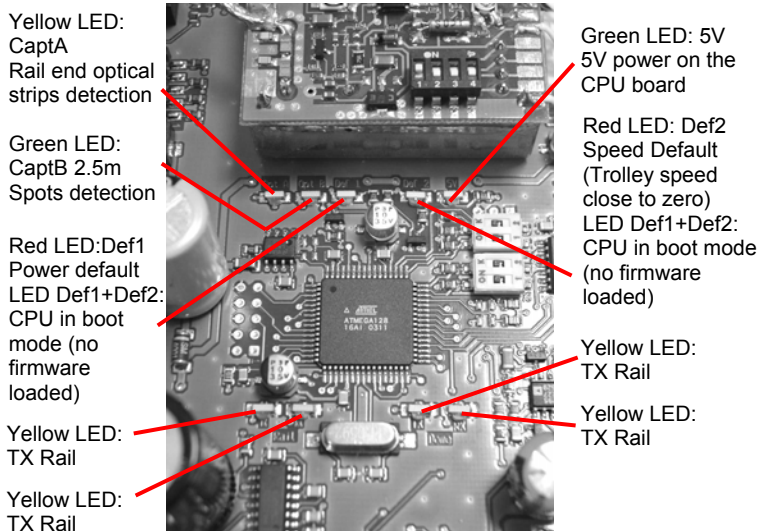

Trolley CPU Board

- Note all failures.

14. Install the Cowling

Mirrored cowling is used to conceal the location of the camera trolley. Grooves in the lower part of the rail are used to secure the cowling.

Note: The cowling is scored 10mm (0.4in) from its edges to enable the edges to fold toward its mirrored side. The fold allows the cowling to secure to the rail grooves.

Note: This is a two person job.

Tools, Equipment, and Parts Required for this Operation

- Proper lift equipment (scissor lift with extended work platform is recommended)
- Cowling roll
- Plastic card similar to a credit card (do not use your personal credit card)
- Ruler and cutter
- Soft white gloves.

Procedure

With you and your helper wearing soft white gloves:

A. Bend the long edges of the cowling toward the mirrored side.

B. Secure the cowling.

Have your helper hold the cowling roll just under the lower part of the structure with its mirrored side facing down. Then using a flat plastic card, SLOWLY and CAREFULLY insert one end of the cowling into the groove until it is completely secured in the rail.



CAUTION: Ensure ends of the cowling at the start end of the rail are even when curved to fit in the grooves. If not, the cowling will not align with the grooves as you insert it.

C. Repeat Step B to insert the other end of the cowling into the opposite groove.

Note: Bends and waves may appear in the cowling. These will disappear once the cowling is completely secured.

D. Remove excess cowling.

Use a ruler and cutter to cut off excess cowling at each end of the rail.

15. Install End Covers

Tools, Equipment, and Parts Required

- Proper lift equipment (scissor lift with extended work platform is recommended)
- End covers (2)
- Cover screws (8).

Install an end cover to each end of the rail using four Phillips-head screws each.

INSTALLATION IS COMPLETE.

Ordering Parts

Product Code	Description
Trolley	
ADRL3EVCUPE	SensorRail III, fully equipped trolley, with 2.4GHz HF transmitter, Dome VII, PAL
ADRL3WHEELSP	SensorRail III, 4 trolley wheels, universal
ADRL3DRVSYS	SensorRail III, driving system, with pressure roller, mount, universal
ADRL3MOTORP	SensorRail III, motor, universal
ADRL3DRVACCP	SensorRail III, driving system accessories, with gear & belt, universal
ADRL3CMF25U (OBS)	SensorRail III, sliding contact, universal
ADRL3CPUU	SensorRail III, CPU board, PAL
ADRL3RFT24P	SensorRail III, RF link, transmitter 2,4GHz, PAL
ADRL3ATEN24U	SensorRail III, RF transmitter antennas 2,4GHz , PAL
ADRL3RFT58P	SensorRail III, RF transmitter 5,8GHz, PAL
ADRL3ATEN58U	SensorRail III, PowerRail, RF antenna transmitter 5,8GHz, PAL
KST25	Set of 4 copper/graphite collectors
KST25DC	SensorRail 3 dust collector kit
KST25-BRKFR	Bracket for the SensorRail KST25 collectors front 3 bends
KST25-BRKR	Bracket for the SensorRail KST25 collectors rear 2 bends
ADRL3RXBRK	Rx antenna black plastic kit with screws
ADRLCIT	SR3 copper install tool
ADRLST	SR3 end stop/strap tool
ADRLSTBL100	Strapping tape black, 100m (328.1ft)
ADSMA10DB	SR3 RF attenuator 10dB Tx Ant
ADSMA15DB	SR3 RF attenuator 15dB Tx Ant
ADSMA20DB	SR3 RF attenuator 20dB Tx Ant
ADSMA30DB	SR3 RF attenuator 30dB Tx Ant
ADRL3ESWCU	AD SensorRail control utility version 1.0 (available from Tech Support only)

PowerRail	
ADRL3PWRLP	SensorRail III, PowerRail complete 27Vdc, with RF Receiver, antenna PAL
ADRL3PWROP	SensorRail III, PowerRail only 27Vdc, PAL
ADRL3PWRRECP	SensorRail III, PowerRail, RF receiver 2,4GHz, PAL
ADRL3PWRANTP	SensorRail III, PowerRail, RF receiver antenna 2,4GHz, PAL
ADRL3PWRR58P	SensorRail III, PowerRail, RF receiver 5,8GHz, PAL
ADRL3PWRA58P	SensorRail III, RF antenna receiver 5,8GHz, PAL

Product Code	Description
Rail	
ADRL3TRACKU	SensorRail III, full rail 5m (16,4ft), with PVC holder, 4 jointing plates, 2 stirrups
ADRL3TRACK5U	SensorRail III, rail only 2,5m x 2, with 4 jointing plates, 18 screws, universal
ADRL3FE901U	SensorRail III, PVC holder 2,5m x 2, universal
ADRL3ETRIERU	SensorRail III, 2 stirrups, universal
ADRL3RESORTU	SensorRail III, C125-180-360, 4 springs, universal
ADRL31350U	SensorRail III, 2 N°1350, universal
ADRL3OPTICU	SensorRail III, optical strip (7,5 meters), universal
ADRL3UNVI55U	SensorRail III, copper, VA860/8-55, universal
ADRL3UNVI90U	SensorRail III, copper, VA860/8-90, universal
ADRL3UNVI100U	SensorRail III, copper, length >100m, universal
SR3-END-COVER	SensorRail III NEW end covers and accessories
ADRL3ECB	SR3E end cover black plastic kit
ADRLEST	SR3 end stop/strap tool
ADRLSTBL100	Strapping tape black, 100m (328.1ft)
ADRL3-AUX-BRK	Aux bracket kit stirrup

Copper Track	
ADRL3CUI10U	SensorRail III, copper tracks 10m (32,81ft), 4 rolls of 10m, universal
ADRL3CUI15U	SensorRail III, copper tracks 15m (49,21ft), 4 rolls of 15m, universal
ADRL3CUI20U	SensorRail III, copper tracks 20m (65,62ft), 4 rolls of 20m, universal
ADRL3CUI25U	SensorRail III, copper tracks 25m (82,02ft), 4 rolls of 25m, universal
ADRL3CUI30U	SensorRail III, copper tracks 30m (98,43ft), 4 rolls of 30m, universal
ADRL3CUI35U	SensorRail III, copper tracks 35m (114,83ft), 4 rolls of 35m, universal
ADRL3CUI40U	SensorRail III, copper tracks 40m (131,23ft), 4 rolls of 40m, universal
ADRL3CUI45U	SensorRail III, copper tracks 45m (147,64ft), 4 rolls of 45m, universal
ADRL3CUI50U	SensorRail III, copper tracks 50m (164,04ft), 4 rolls of 50m, universal
ADRL3CUI55U	SensorRail III, copper tracks 55m (180,45ft), 4 rolls of 55m, universal
ADRL3CUI60U	SensorRail III, copper tracks 60m (196,85ft), 4 rolls of 60m, universal
ADRL3CUI65U	SensorRail III, copper tracks 65m (213,25ft), 4 rolls of 65m, universal
ADRL3CUI70U	SensorRail III, copper tracks 70m (229,66ft), 4 rolls of 70m, universal
ADRL3CUI75U	SensorRail III, copper tracks 75m (246,06ft), 4 rolls of 75m, universal
ADRL3CUI80U	SensorRail III, copper tracks 80m (262,47ft), 4 rolls of 80m, universal
ADRL3CUI85U	SensorRail III, copper tracks 85m (278,87ft), 4 rolls of 85m, universal
ADRL3CUI90U	SensorRail III, copper tracks 90m (295,28ft), 4 rolls of 90m, universal
ADRL3CUI95U	SensorRail III, copper tracks 95m (311,68ft), 4 rolls of 95m, universal
ADRL3CUI100U	SensorRail III, copper tracks 100m (328,08ft), 4 rolls of 100m, universal
ADRLCIT	SR3 copper install tool

Product Code	Description
Mirrored Cowling	
ADRL3BUL10U	SensorRail III, mirrored cowling 10m (32,81ft), universal
ADRL3BUL15U	SensorRail III, mirrored cowling 15m (49,21ft), universal
ADRL3BUL20U	SensorRail III, mirrored cowling 20m (65,62ft), universal
ADRL3BUL25U	SensorRail III, mirrored cowling 25m (82,02ft), universal
ADRL3BUL30U	SensorRail III, mirrored cowling 30m (98,43ft), universal
ADRL3BUL35U	SensorRail III, mirrored cowling 35m (114,83ft), universal
ADRL3BUL40U	SensorRail III, mirrored cowling 40m (131,23ft), universal
ADRL3BUL45U	SensorRail III, mirrored cowling 45m (147,64ft), universal
ADRL3BUL50U	SensorRail III, mirrored cowling 50m (164,04ft), universal
ADRL3BUL55U	SensorRail III, mirrored cowling 55m (180,45ft), universal
ADRL3BUL60U	SensorRail III, mirrored cowling 60m (196,85ft), universal
ADRL3BUL65U	SensorRail III, mirrored cowling 65m (213,25ft), universal
ADRL3BUL70U	SensorRail III, mirrored cowling 70m (229,66ft), universal
ADRL3BUL75U	SensorRail III, mirrored cowling 75m (246,06ft), universal
ADRL3BUL80U	SensorRail III, mirrored cowling 80m (262,47ft), universal
ADRL3BUL85U	SensorRail III, mirrored cowling 85m (278,87ft), universal
ADRL3BUL90U	SensorRail III, mirrored cowling 90m (295,28ft), universal
ADRL3BUL95U	SensorRail III, mirrored cowling 95m (311,68ft), universal
ADRL3BUL100U	SensorRail III, mirrored cowling 100m (328,08ft), universal
ADRL3BUL3.5U	3.5 meters mirror cowling to add when using SR3-END-COVER

Specifications (Excluding Dome Camera)

Operational

Maximum rail length.....	100m (328.1ft)
Video travel distance	97m (318.3ft)
Travel speed:	
Nominal	3m/s (9.8ft/s)
Preset.....	6m/s (19.6ft/s)
Preset positioning.....	0.3m/s (0.98ft/s)
Patrol mode.....	1.5m/s (4.9ft/s)
Initialization mode	1m/s (3.3ft/s)
Cowling density.....	f0.7–f0.95 (15–16% penetration)
Camera.....	See manual supplied with camera
Controller	See manual supplied with controller

Electrical

Power requirements:

Supply voltage (auto switched) ...	90–240Vac, 50/60Hz
Current (120Vac).....	5A typical (10A surge)
Current (240Vac).....	2.5A typical (5A surge)

RF link transmitter:

RF frequency range	2.4–2.483GHz (PAL) over 5 channels
Transmission power	10mW EIRP
Video input	Composite PAL 1V p-p
Video bandwidth.....	30Hz–5MHz
Power supply.....	12.8–15Vdc
Nominal current.....	240mA

RF link receiver:

RF frequency range	2.4–2.483GHz (PAL) over 5 channels
Video output.....	Composite PAL 1V p-p
Sensitivity.....	–86dBm (21dBμV)
Power supply.....	8–10Vdc
Nominal current.....	250mA

Trolley motor:

Nominal voltage	24Vdc
Nominal speed	6700rpm clockwise
Nominal torque.....	1250m Nm
Nominal current (w/o load)	0.120A
Speed constant	287rpm/V

Cabling

Power	IEC connector
Video*	Coaxial RG59/U
RS-422 data	Cat. 5. 1 x twisted pair, shielded

* KX-6 for <300m from PowerRail to matrix switcher,
KX-8 for <800m from PowerRail to matrix switcher.

Environmental

Operating temperature	–10 to 50°C
Storage temperature	–20 to 65°C
Rate of change per hour (max.)	10°C per hour
Altitude (max.).....	3660m above sea level
Relative humidity.....	0 to 95% non-condensing

Mechanical

Single rail section:

Length	2.5m (8.2ft)
Width	188mm (7.4in)
Height (w/o cowling)	141mm (5.6in)
Height (w/cowling)	255mm (10in)
Weight	6.7kg/m (14.7 lbs/3.3ft)
Material.....	Extruded aluminum
Cowling material.....	175 micron Polyester film
Trolley (w/dome camera)	
Dimensions (H x W x L).....	225 x 131 x 400mm
Weight	5kg (11 lbs)

Declarations

Regulatory Compliance

Emissions	EN 61000-3-2 EN 61000-3-3
Immunity	EN 301489-3
Radio	EN 300440-2
Safety	EN 60950 EN 50371

Declarations

Thank you for using American Dynamics products. We support our products through an extensive and worldwide network of dealers. The dealer, through whom you originally purchased this product, is your point of contact if you have a need for service or support. Our dealers are fully empowered to provide the very best in customer service and support. Dealers should contact American Dynamics at (800) 507-6268 or (561) 912-6259 or on the web at www.americandynamics.net.

WARRANTY DISCLAIMER: Sensormatic Electronics Corporation makes no representation or warranty with respect to the contents hereof and specifically disclaims any implied warranties of merchantability or fitness for any particular purpose.

NOTICE: The information in this manual was current when published. The manufacturer reserves the right to revise and improve its products. All specifications are therefore subject to change without notice.

LIMITED RIGHTS NOTICE: For units of the Department of Defense, all documentation and manuals were developed at private expense and no part of it was developed using Government Funds. The restrictions governing the use and disclosure of technical data marked with this legend are set forth in the definition of “limited rights” in paragraph (a) (15) of the clause of DFARS 252.227.7013. Unpublished - rights reserved under the Copyright Laws of the United States.

TRADEMARK NOTICE: *American Dynamics* and *Sensormatic* are trademarks or registered trademarks of Sensormatic Electronics Corporation. Other product names mentioned herein may be trademarks or registered trademarks of Sensormatic or other companies.

COPYRIGHT: Under copyright laws, the contents of this manual may not be copied, photocopied, reproduced, translated or reduced to any electronic medium or machine-readable form, in whole or in part, without prior written consent of Sensormatic Electronics.

MDR 04/2006

1

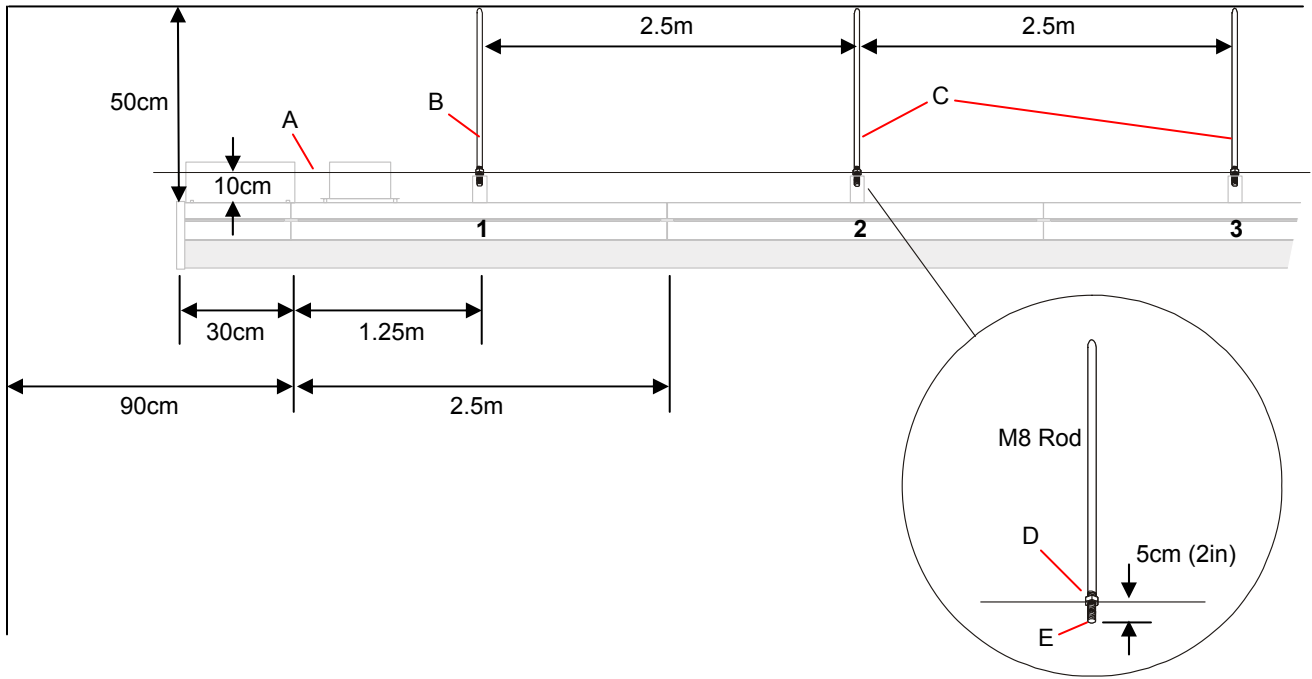

2

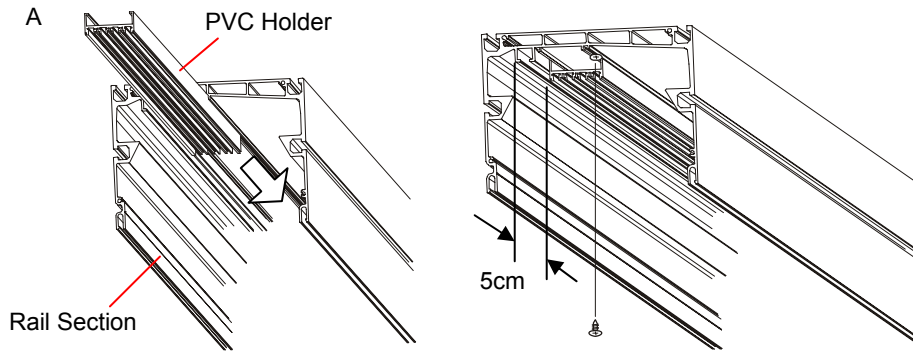

3

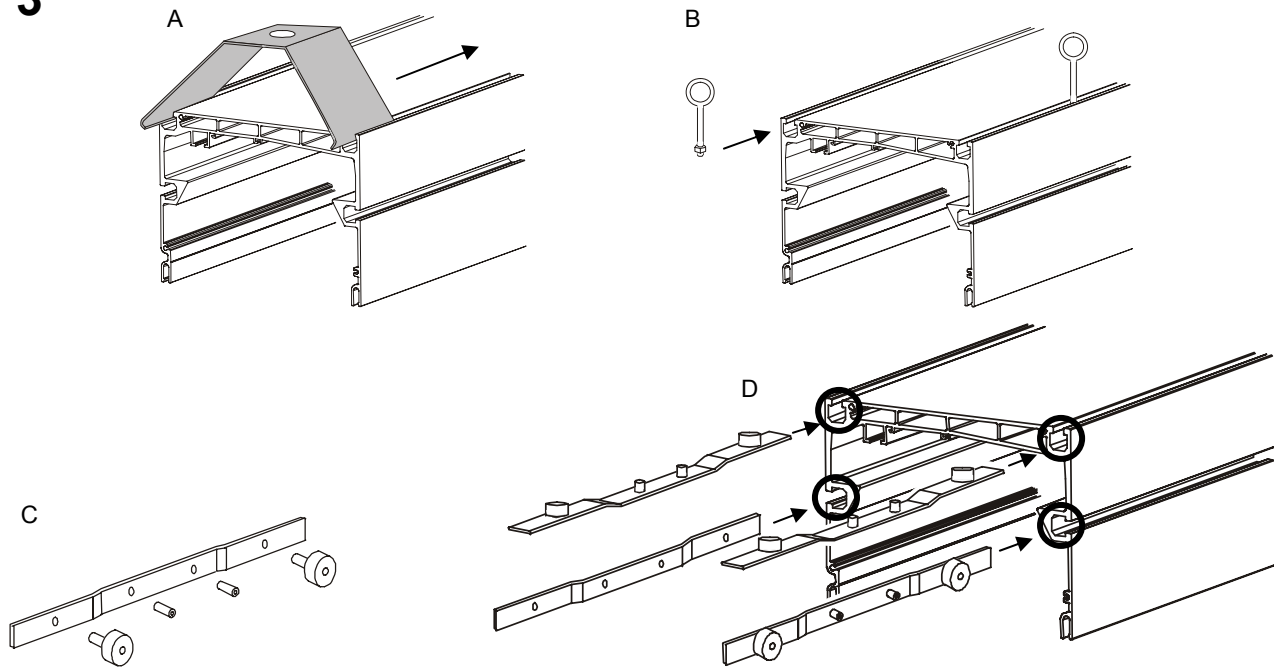

4

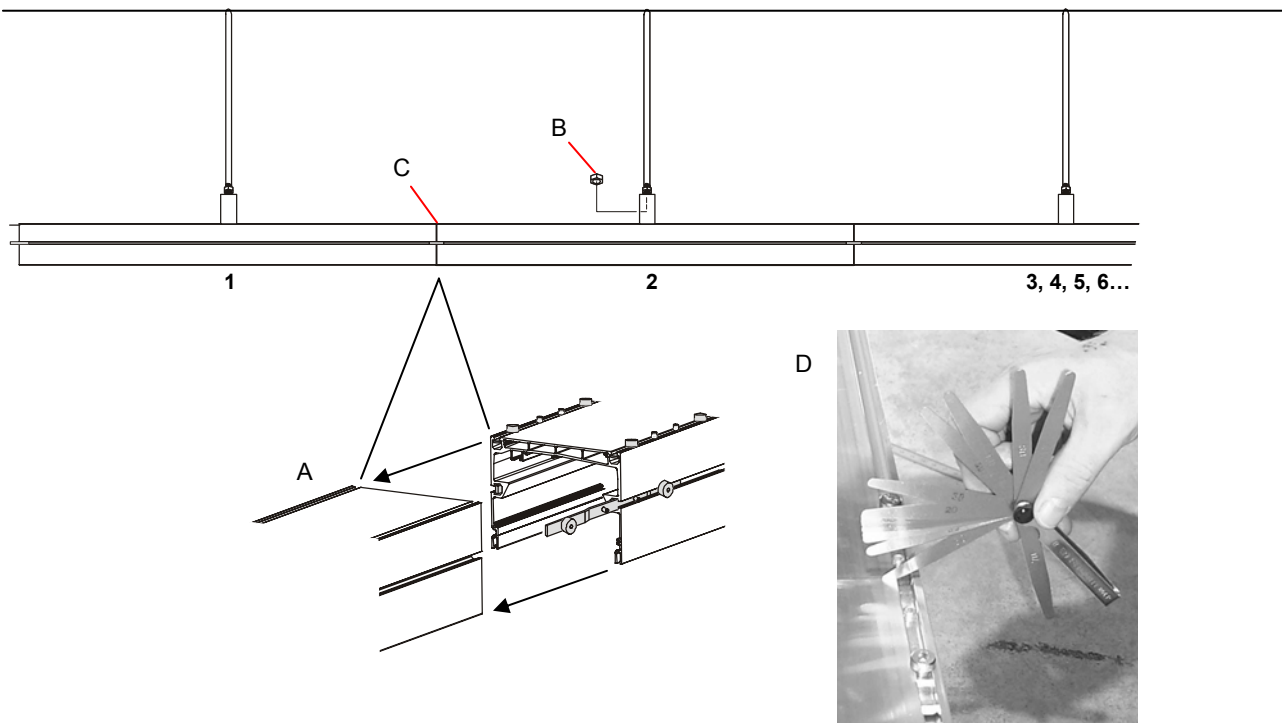

5

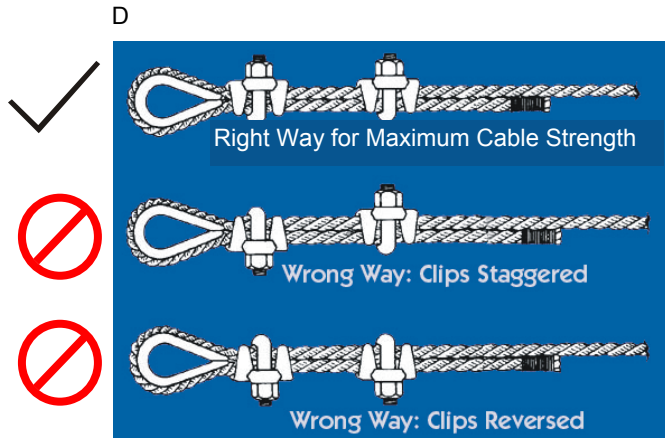
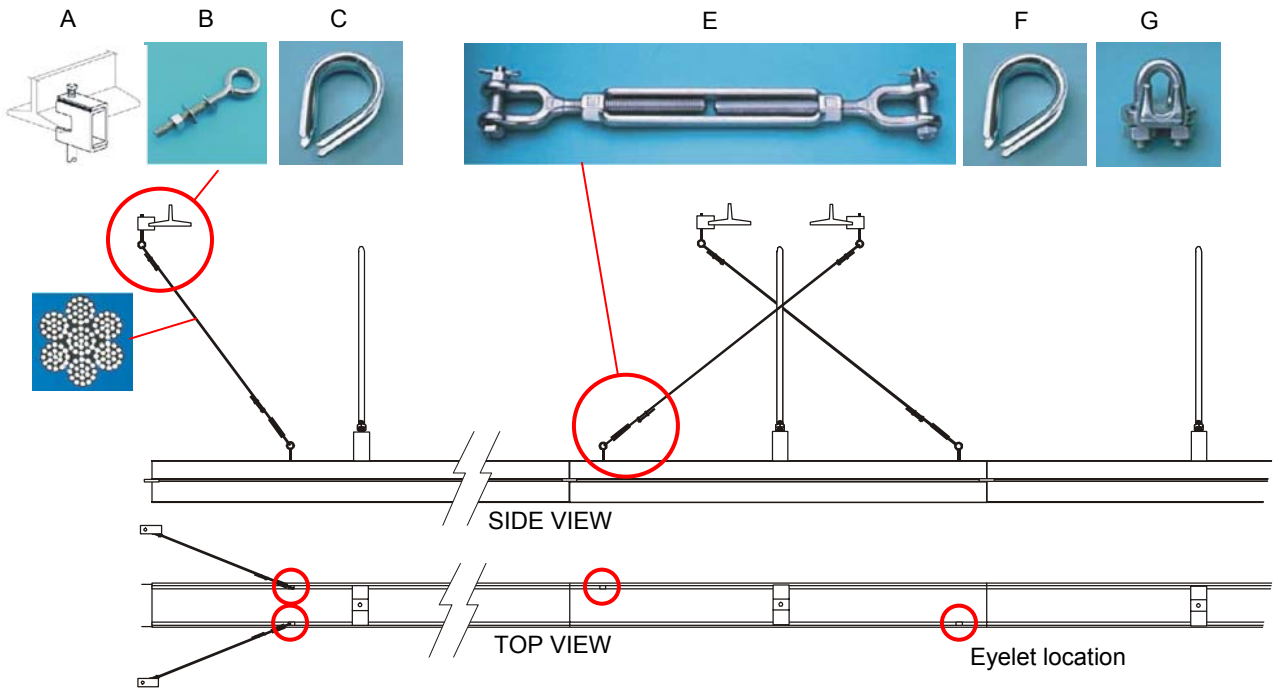

6

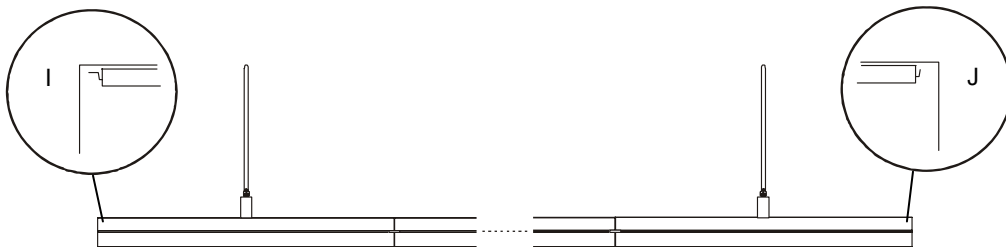
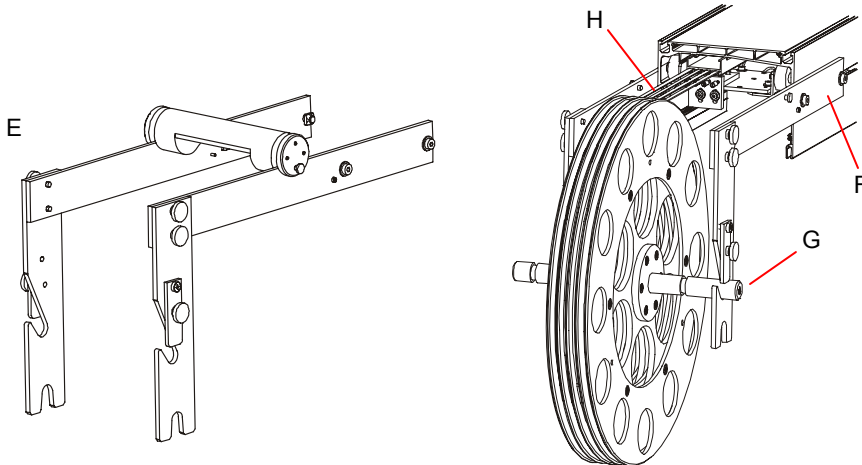
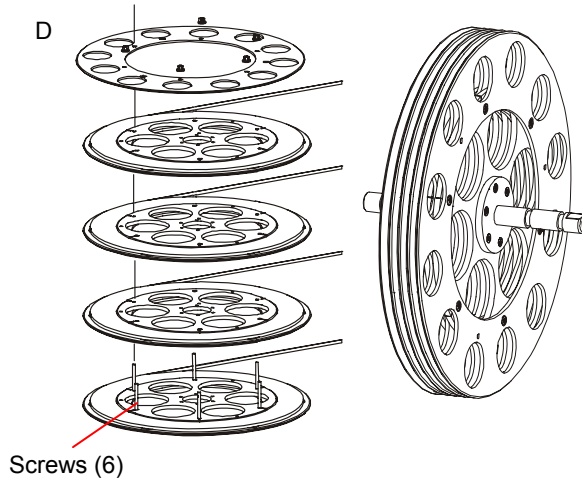
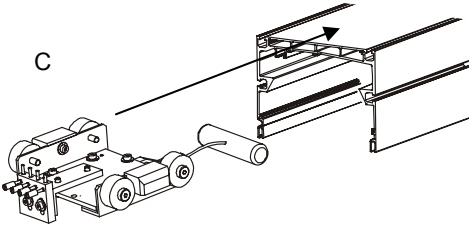
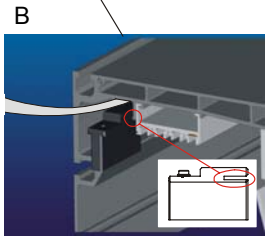
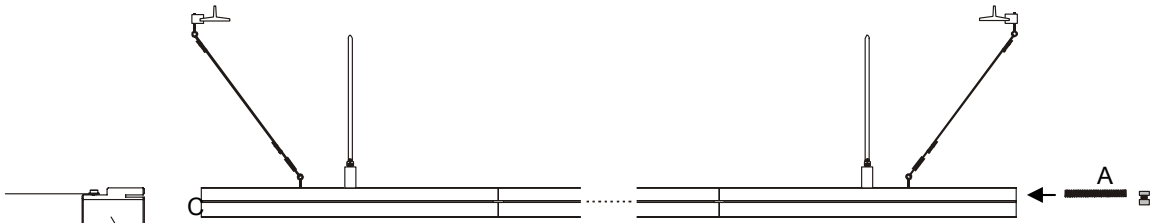

7

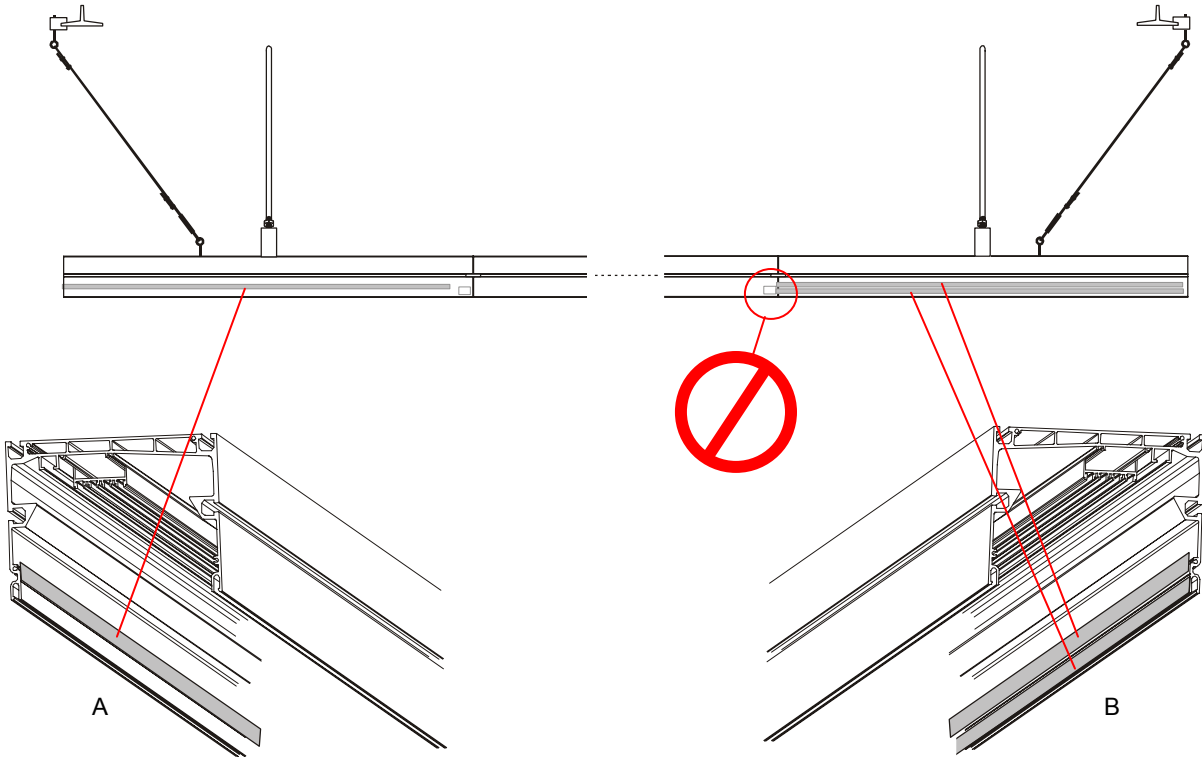

8

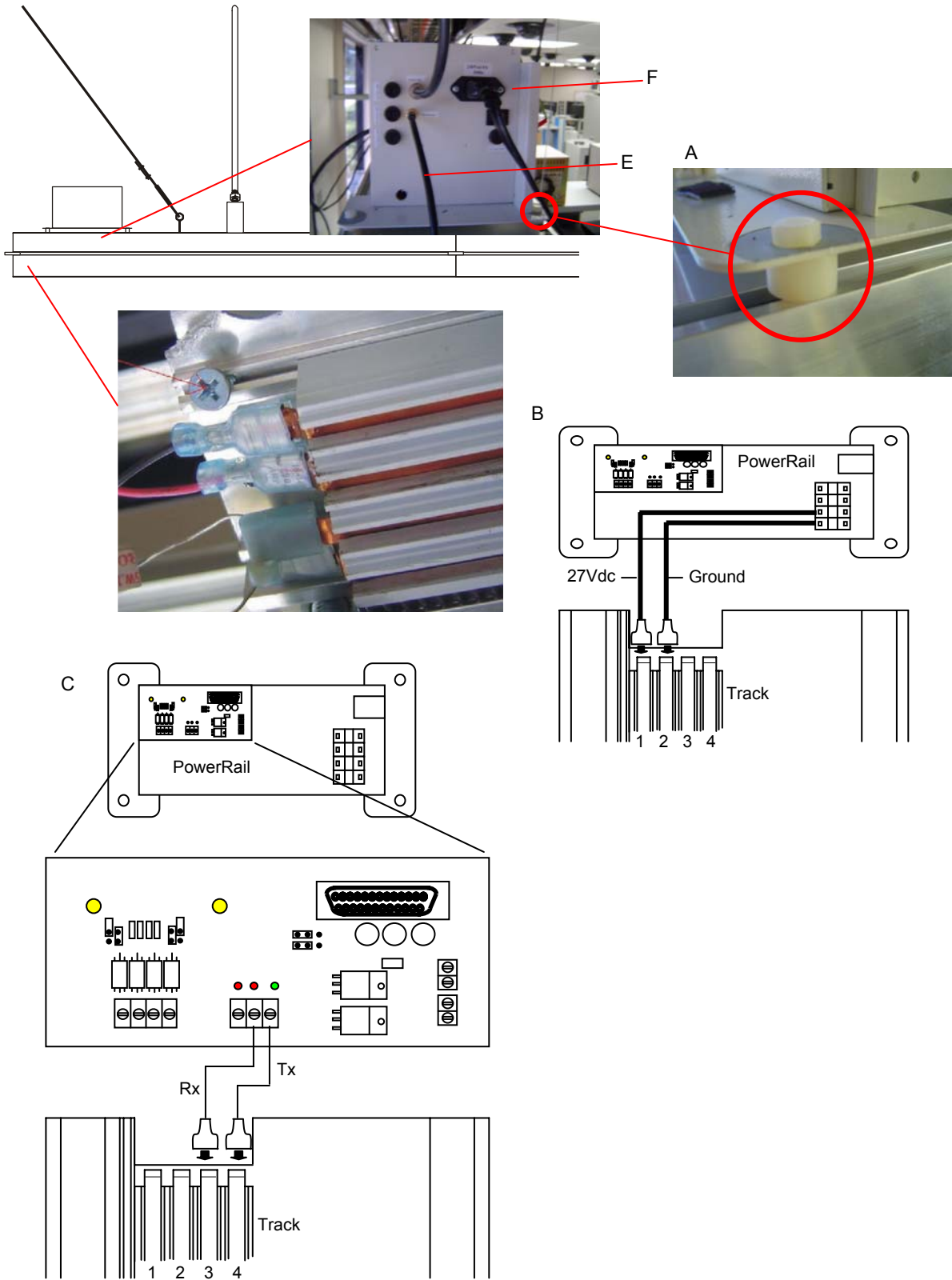

9

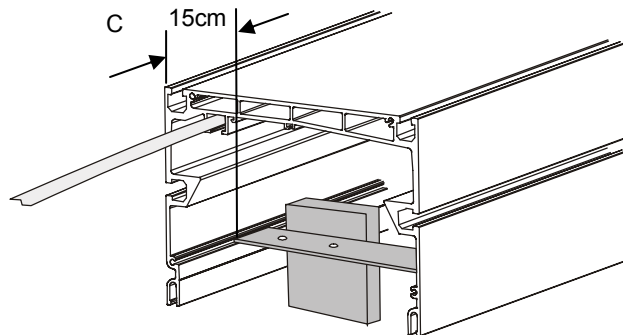
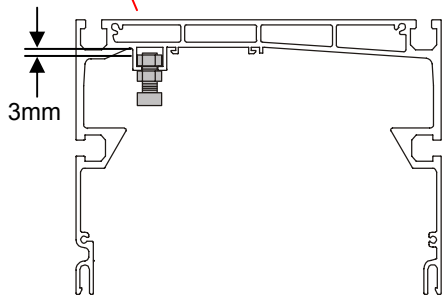
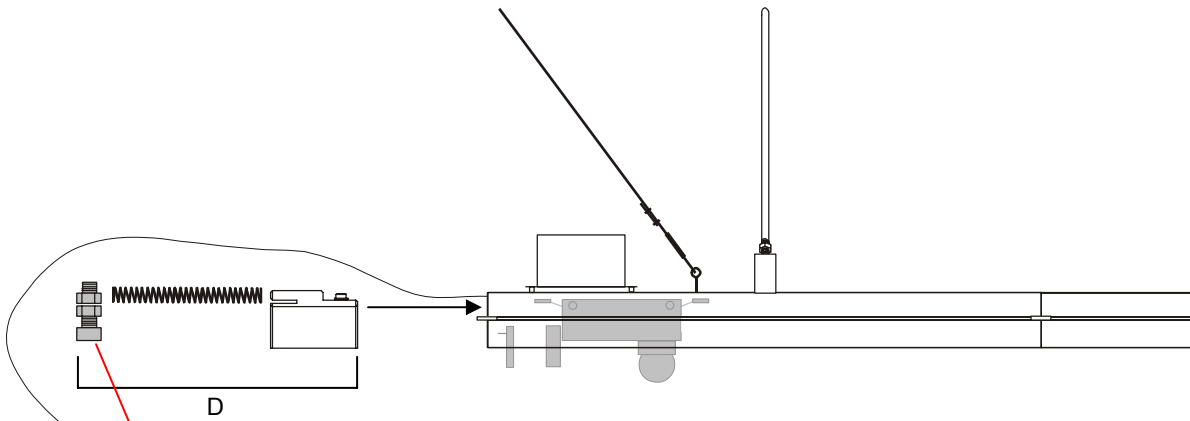
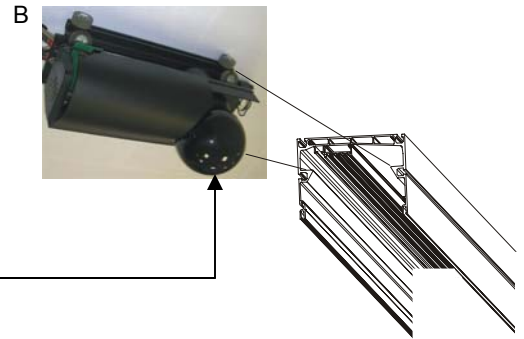
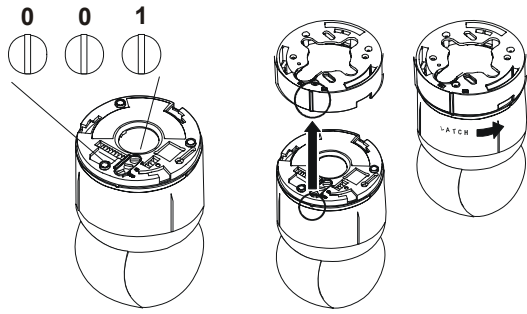
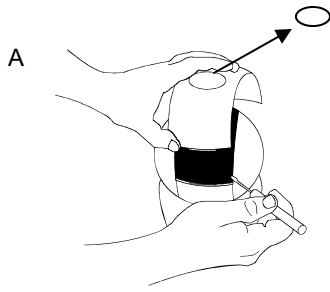

10

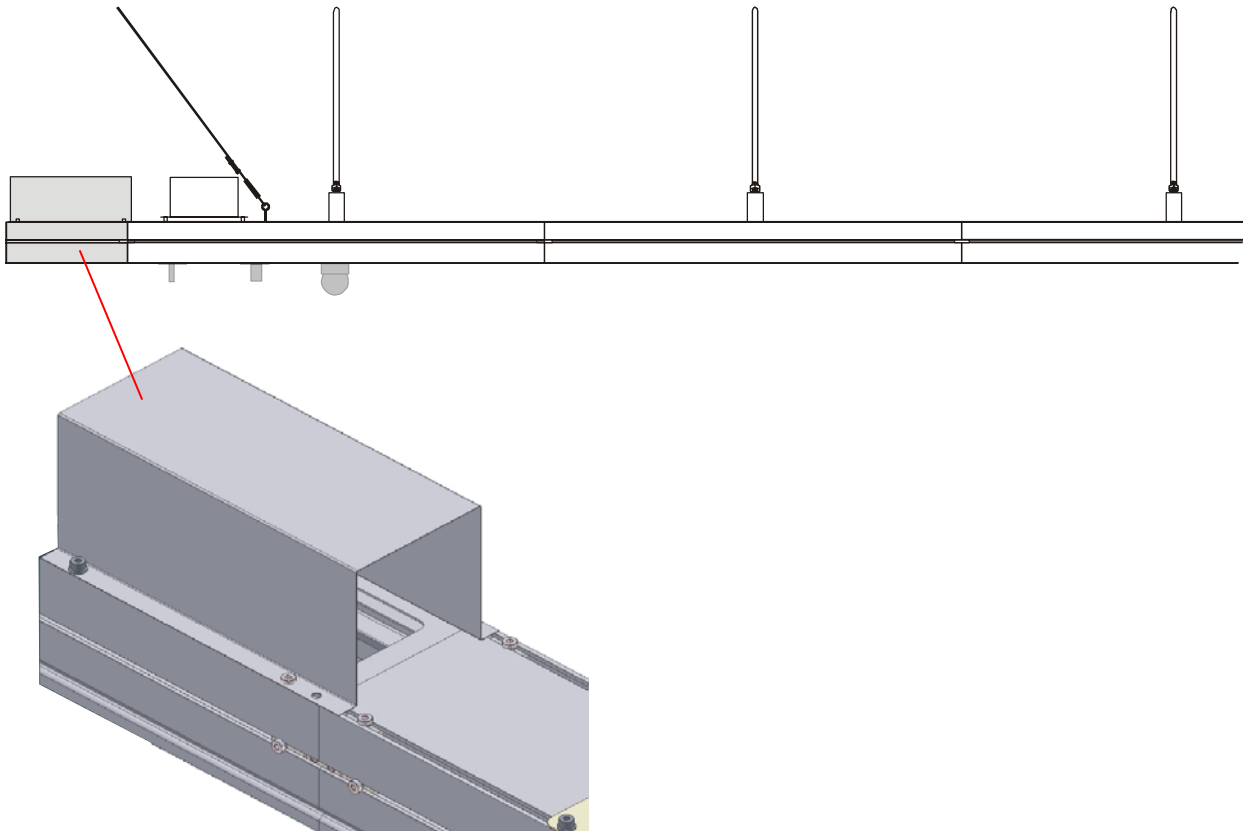

11

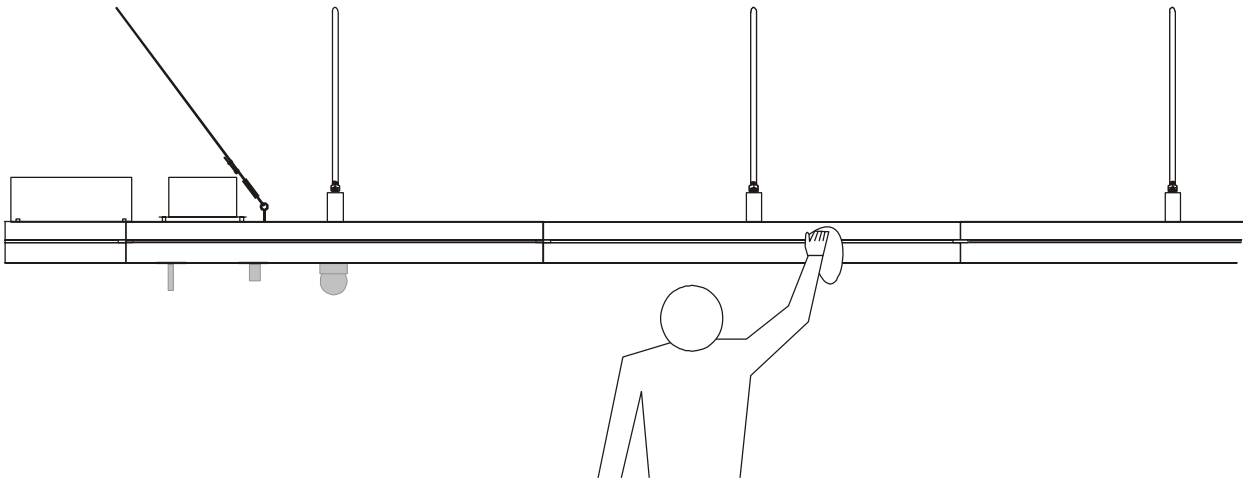

12

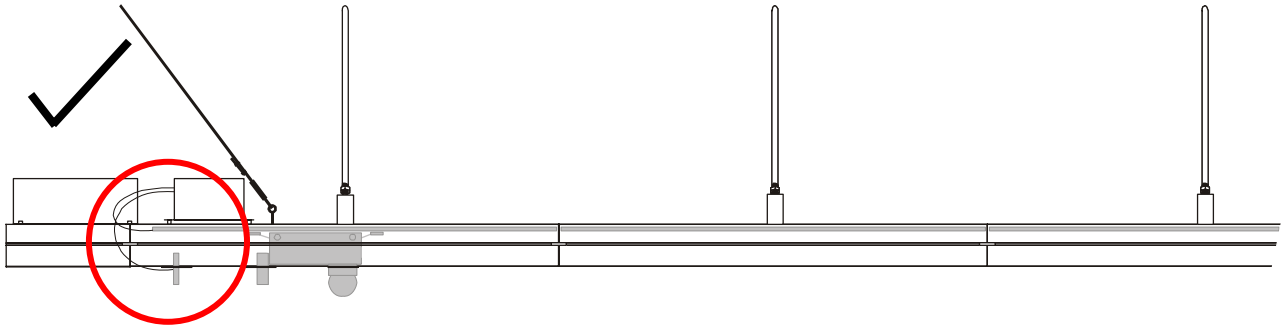

13

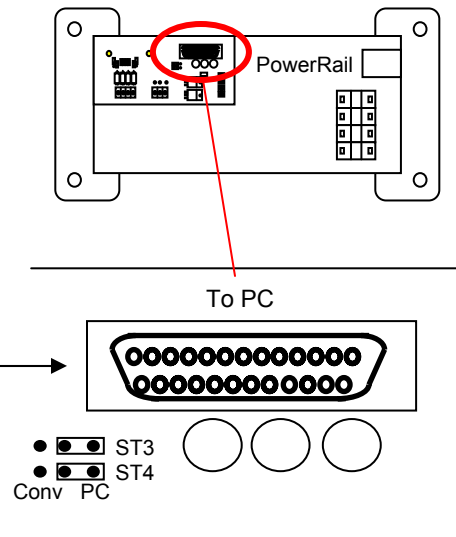
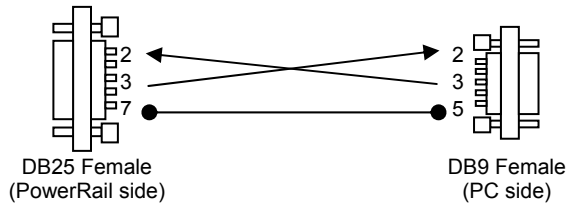
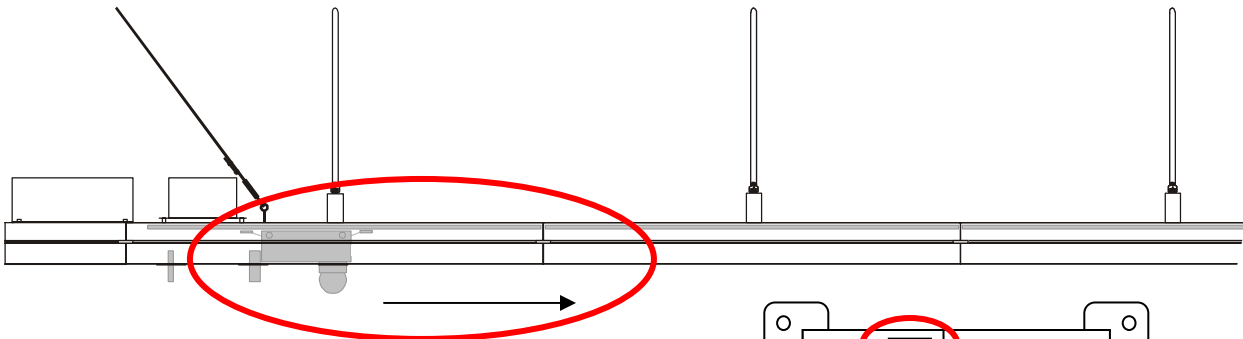

14

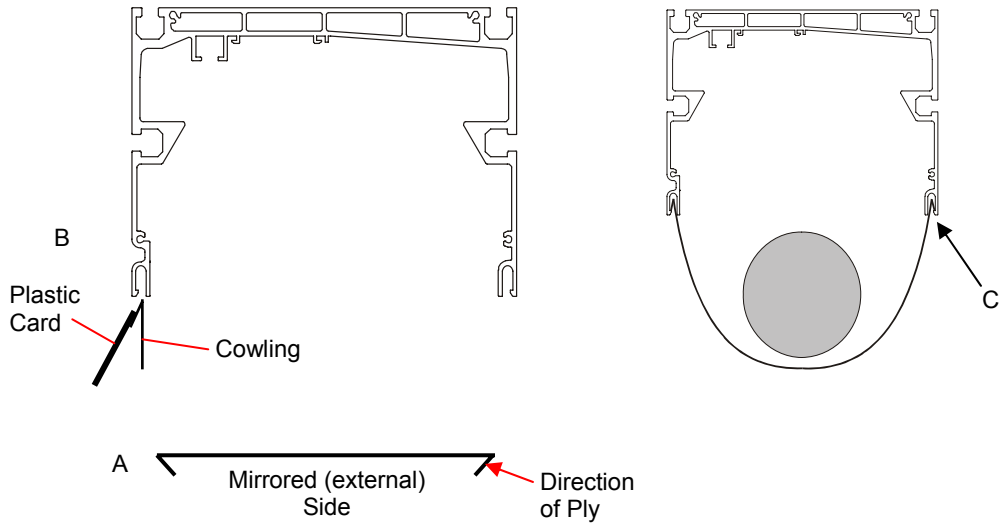

15

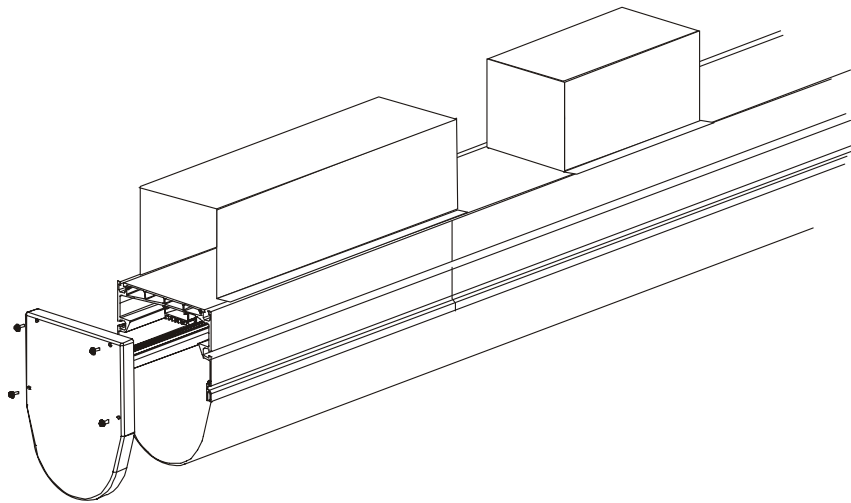

x2

Appendix A: RF link DIP switch settings

If 2.4GHz devices interfere with the SensorRail, select one of the following alternate frequencies using the four-position DIP switch located on the transmitter board of the trolley.

Channel	DIP Switch			
	1	2	3	4
Channel 1 (2414.5MHz)	ON	OFF	OFF	OFF
Channel 2 (2428.5MHz)	OFF	ON	OFF	OFF
Channel 3 (2442.5MHz)	ON	ON	OFF	OFF
Channel 4 (2456.5MHz)	OFF	OFF	ON	OFF
Channel 5 (2470.5MHz)	ON	OFF	ON	OFF

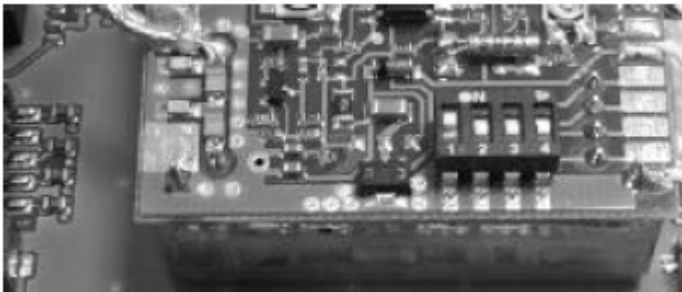

Appendix B: Alternate RF antenna location

Use Install Kit ADRL3RXBRK.

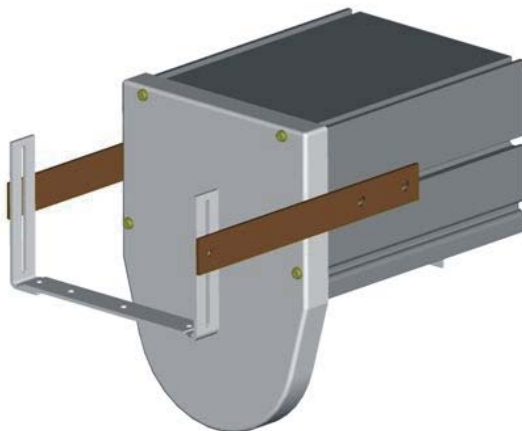

Appendix C: AD SensorRail Control Utility

Camera Control, SensorRail, and PC Functions

Camera Control Functions

Dome camera and rail functions

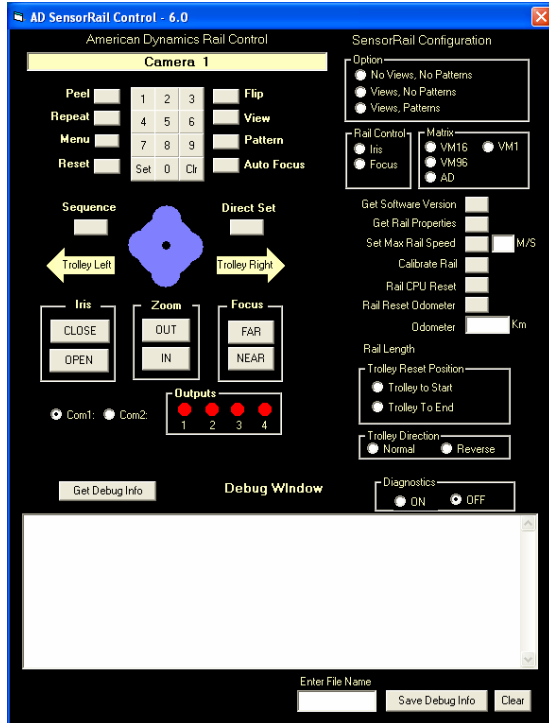

Select Dome Camera. To select the camera dome, click 0-9 keys on the numeric keypad and then SET. The display indicates the currently selected camera. To erase an incorrect number, click CLR before SET.

Peel. Click to have the dome perform the Apple Peel pattern. Initiate any PTZ function to cancel this pattern.

Reset. Doubleclick to reset the dome camera.

Flip. Click to move the pan axis of the dome 180°.

View (also known as Target, Preset). To go to a stored view, use the numeric keypad to enter the view number and click VIEW. To store a view, click SET, enter the number, and then click VIEW. The latest software supports 16 views.

Pattern (also known as Tour). To run a stored pattern, enter the pattern number (1-3) using the numeric keypad and then click PATTERN.

- To repeat a pattern continuously, click REPEAT, enter the pattern number (1-3) using the numeric keypad, and then click PATTERN.
- To define a pattern, click SET, enter the pattern number (1-3) using the numeric keypad and click PATTERN. Pan, tilt, and zoom the dome until the pattern has run. To end the pattern, click PATTERN.
- To review the pattern just defined, click PATTERN. If the pattern is acceptable, click SET and then PATTERN to replace the pattern designated at the beginning of the definition sequence.

Auto Focus. Click to return iris and focus functions to automatic.

Sequence. The software is capable of creating 16 different sequences, each with 16 steps. You can setup sequences by following these procedures. To program a sequence:

1. Click SET, then the keypad number of the sequence and then click SEQUENCE. The sequence edit information is displayed in message window. The current field to edit starts blinking.
2. Enter the step number using the numeric keypad, and then click SET.
3. Enter the preset using the numeric keypad, and then click SET.
4. Enter the dwell using the numeric keypad, and then click SET.
5. Repeat steps 3–5 for each step.
6. Click SEQUENCE to finish programming.

To run a sequence, enter the sequence number using the numeric keypad and then click SEQUENCE. The message window indicates the sequence running and the current step number. To stop the sequence, click SEQUENCE.

Pan and Tilt Joystick. Click and drag the black dot at the center of the joystick in the direction that the dome is to go. The farther the drag, the faster the dome goes. Release the mouse button to release the dot and stop the dome.

Iris (Close, Open). Click CLOSE or OPEN to manually adjust the iris level of the dome.

Zoom (Out, In). Click OUT or IN to change the dome's field of view (FOV).

Focus (Far, Near). Click FAR or NEAR to manually focus the dome.

SensorRail Control Functions

Trolley Left. Click to move the trolley left.

Trolley Right. Click to move the trolley right.

Outputs. Doubleclick 1 or 2, or click 3 or 4 to select the appropriate camera auxiliary port.

Option. Click the radio button for the appropriate Rail Target/Pattern option.

Rail Control. Click to choose which keyboard key (IRIS or FOCUS) will be used to move the trolley.

Matrix. Click the appropriate radio button to select the matrix switcher used.

Get Software Version. Click to show the SensorRail version number in the utility display at the bottom of the screen.

Get Rail Properties. Click to display current rail settings in the utility display at the bottom of the screen.

Set Max Rail Speed. Click the input window to the right of this key, and enter the maximum manual rail speed (1-6). Click the key to send this value to the trolley.

Calibrate Rail. Click to cause the trolley to execute a calibration cycle.

Rail CPU Reset. Doubleclick to reset the Rail CPU.

Rail Reset Odometer. Doubleclick to reset the rail odometer to zero.

Odometer. Shows the current distance traveled by the trolley in kilometers.

Trolley Reset Position. Click the appropriate radio button to change the trolley reset position to be either at the start of the rail or at the end of the rail.

Trolley Direction. Used when two rails are installed back-to-back. Click the appropriate radio button to have the trolley run normally or to reverse its movement so camera movement is correct when viewed on a monitor when normal rail function is reversed respective to another rail.

PC Functions

Com1/2. Click the appropriate radio button to select the serial communications port for the computer.

Camera Monitor Functions

Camera monitor functions (highlighted areas change)

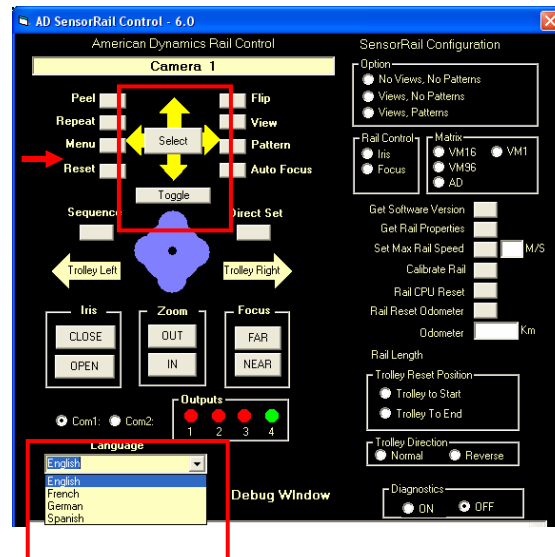

Menu. Click MENU to command the dome to enter the camera monitor's on-screen menu mode, as well as change the operator interface to the Menu Control View (the keypad changes to a "Select" function). The language also can be changed to French, German, or Spanish.

Note: Click the UP, DOWN, LEFT, and RIGHT arrows to highlight the desired function on the monitor, and then click SELECT. Click the TOGGLE key to change the value of the function. Click MENU to return to the camera keypad.

DirectSet. Click DIRECT SET to have the dome display the Directset menu on the camera monitor. To begin any DirectSet function, enter the number on the video display, and then click DIRECTSET. To clear the menu, click DIRECTSET again.

Debug and Diagnostic Functions

For future use.