



TOUCH TRACKER with Multiplexer

PARTS REQUIRED

AD TOUCH TRACKER 16 Installation Kit:

Part Number 0351-0474-06

Description	Qty.	Part No.
Modular cable assy	4.3m	6003-0047-01
Screw, M2.9x9.5	1	5899-0004-102
Anchor, 4-8x.750	2	2880-0083-01
Screw, #8x1	2	2816-7634-44
Conn, 1x5pos	1	2109-0254-04
Lug, 22-16AWG	3	2141-0002
Cable, 3-cond, 18AWG	5m	6002-0024-01
Interconnect box	1	0300-1000-01
Multiplexer cable assy	1	0650-1079-01
Hood, D-Sub, 9pos, cable	1	2125-0007-02
Conn, D-Sub, plug, hsg, 9pos	1	2130-0021-01
Contact, pin, D-Sub, 22-26 AWG	1	2103-0092-01

WARNING Shock Hazard!
Disconnect AC Power to the Switch.

CAUTION static sensitive components!
Follow proper handling procedures to prevent component failure.

Installation Procedures

1. Terminate the external interconnect module (EIM) at the end of the SensorNet network. See the diagram on page 2.
For more information on the SensorNet network, refer to the SensorNet Network Guide (PN 8000-0970-01).
2. Mount each EIM on a wall or other surface within 3m (10') of the TOUCH TRACKER controller.
3. Connect the power transformer and SensorNet cable to J3 on each EIM.
4. Wire the DB9 connector to the data cable. If you are using a multiplexer with a DB25 connector, refer to the illustration on page 2. If you are using a multiplexer with a RJ11 connector, refer to the illustration on page 3.
5. Connect the data cable from J1 on the main TOUCH TRACKER EIM to the Remote port at the rear panel of the multiplexer.
6. Connect the modular cable from J2 on EIM to the TOUCH TRACKER controller.
7. Connect the SensorNet cable from the dome to the terminated EIM.
8. Plug each power transformer into a grounded, 3 wire receptacle.
NOTE: If the keypad and backlighting do not illuminate when power is applied, unplug each power transformer and repeat steps 3 through 8.
9. From the TOUCH TRACKER controller, press **Menu** to configure the software for the multiplexer.
10. Using the Tracker Ball, page down the screen to the *Config Devices* menu option.
11. Press the zoom/focus button to select the *Config Devices* menu option.

12. Press **Next** to select the appropriate device for this installation. See the example screen below.

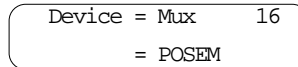

13. Press **Menu** to select the device configuration and return to the Camera Control mode.
14. To configure the TOUCH TRACKER controller as a primary or secondary unit, page down the screen to the *Tog Primary/2nd* menu option.
15. Press the zoom/focus button to select the *Tog Primary/2nd* menu option.
16. Press **Next** to toggle between using the TOUCH TRACKER controller as the primary (Main) unit for the SensorNet polling and alarm monitoring or as the secondary (Call) unit with limited user functionality.
17. Press **Menu** to reset the TOUCH TRACKER controller as a primary or secondary unit. The controller will reboot to the Camera Control Mode.

Multiplexer with DB25, continued

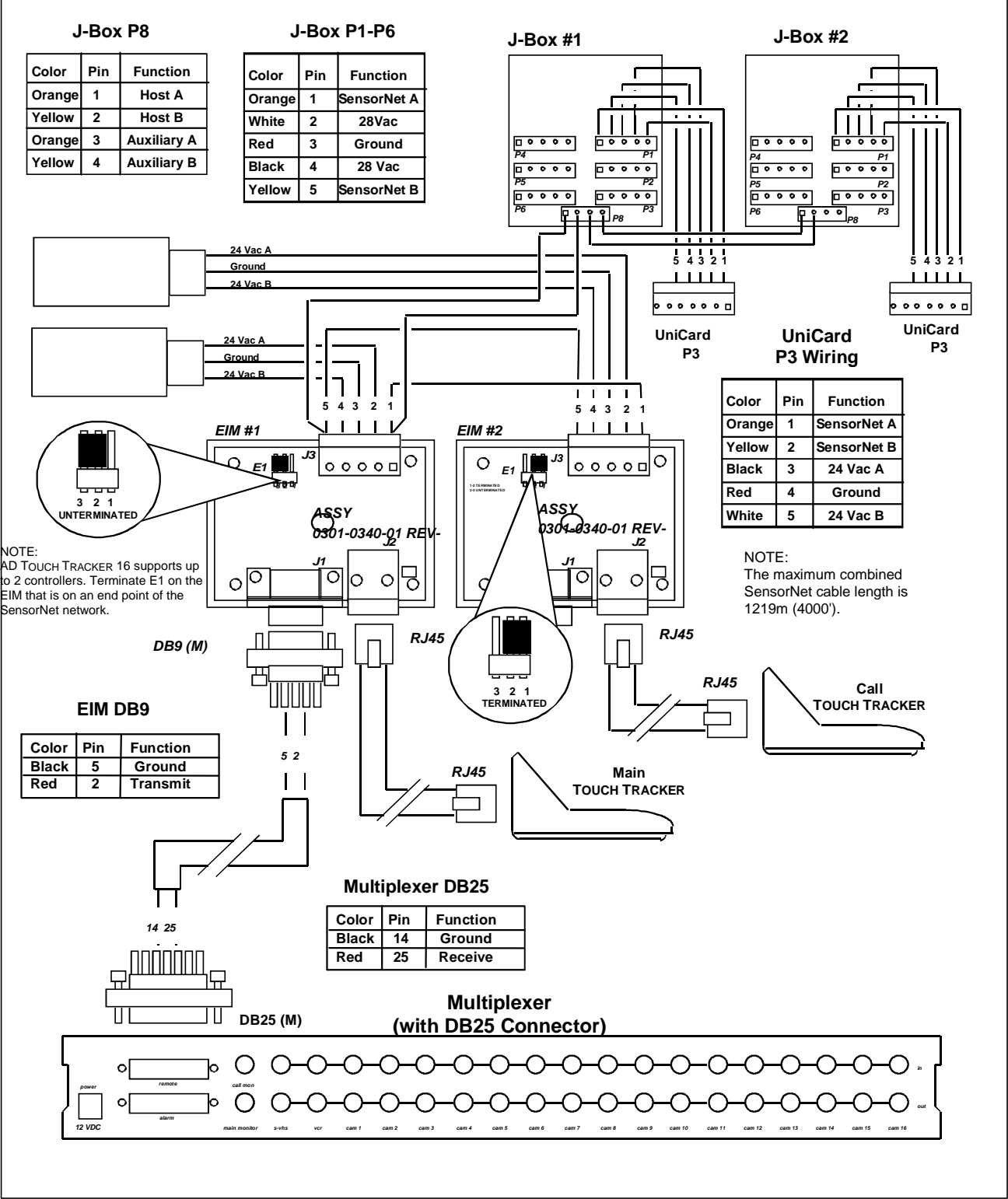

TOUCH TRACKER with Multiplexer, continued

Calibrating the Tracker Ball

1. Press **Menu**. The Calibration menu option will appear on the first line.
2. Press the left zoom/focus button (line 1) to select the Calibration menu option.
3. Follow the instructions on the LCD screen.
4. Press **Menu** to exit.

If you do not follow each instruction on the screen, the dome may not function properly. Re-calibrate the Tracker Ball if the dome does not pan or tilt properly. Calibration is only for the Touch Tracker controller.

brief delay, the controller will return to Camera Control Mode.

Configuring Devices

1. Press **Menu**.
2. Using the Tracker Ball, scroll down to Config Devices.
3. Press the left zoom/focus button (line 1) or right zoom/focus button (line 2) to select the Config Devices menu option.
4. Press **Next** to step to the device configuration for this installation.
5. Press **Menu** to select the device configuration and exit.

Resetting a Dome

1. Use the number buttons to select the dome to reset, then press **Cam**.
2. Press **Menu**.
3. Using the Tracker Ball, scroll down to Reset Dome.
4. Press the left zoom/focus button (line 1) or right zoom/focus button (line 2) to select the Reset Dome menu option.

The dome will send a request to the selected dome to reboot. After a

Toggling between the Primary and Secondary Unit

1. Press **Menu**.
2. Using the Tracker Ball, scroll down to Tog Primary/2nd.
3. Press the left zoom/focus button (line 1) or right zoom/focus button (line 2) to select the Tog Primary/2nd menu option.
4. Press **Next** to toggle between using the primary (Main) unit for SensorNet polling and alarm monitoring or as the secondary (Call) unit with limited user functionality.
5. Press **Menu** to reset the controller as a primary or secondary unit.

The controller will reboot and return to the Camera Control Mode.

Toggling between Zoom and Focus

1. Press **Menu**.
2. Using the Tracker Ball, scroll down to Tog Zoom/Focus.

3. Press the left zoom/focus button (line 1) or right zoom/focus button (line 2) to select the Tog Zoom/Focus menu option.
4. Press **Next** to switch the Zoom and Focus functions between the right and left buttons.
5. Press **Menu** to exit.

Adjusting V-Phase

1. Press **Menu**.
2. Using the Tracker Ball, scroll down to Adjust V-Phase.
3. Press the left zoom/focus button (line 1) or right zoom/focus button (line 2) to select the Adjust V-Phase menu option.
4. Press **Next** or **Previous** to observe V-Phase through the oscilloscope or Fluke scope.
5. Press **Menu** to exit.

Off-line domes or fixed cameras will generate a warning beep and disallow use of the V-Phase utility. For additional information on adjusting V-Phase, see the Service section of the AD TOUCH TRACKER 16 manual.

TOUCH TRACKER with Multiplexer, continued

Providing System Information

1. Press **Menu**.
2. Using the Tracker Ball, scroll down to System Info.
3. Press the left zoom/focus button (line 1) or right zoom/focus button (line 2) to select the System Info menu option. The LCD screen displays the following message:

Primary Unit

4. Press **Next** to step through the following messages:
- 5.

ROM Checksum
0A7B

Pan FSR Calibration
Left Right

Min	11	22	33	44
Max	55	66	77	88

Up Down

Tilt FSR Calibration Values

Product Code
F 7000-0020-0102

Indicates Flash PROM

Product Code
E 0701-0010-0105

Indicates EEPROM

6. Press **Menu** to exit.

Performing SensorNet Ping Test

1. Use the number buttons to select a dome to reset, then press **Cam**.
2. Press **Menu**.
3. Using the Tracker Ball, scroll down to Ping Dome/TTR.
4. Press the left zoom/focus button (line 1) or right zoom focus button to select the Ping Dome/TTR menu option and test the selected dome.
5. Press **Next** to perform the network test on the Primary / Secondary controller unit.
6. Press **Menu** to exit.
Off-line domes or fixed cameras will generate a warning beep and disallow use of the SensorNet network test.