

ENGLISH
FRANÇAIS
ESPAÑOL

VIDEO CASSETTE RECORDER
CTR-024N-2
INSTRUCTION MANUAL

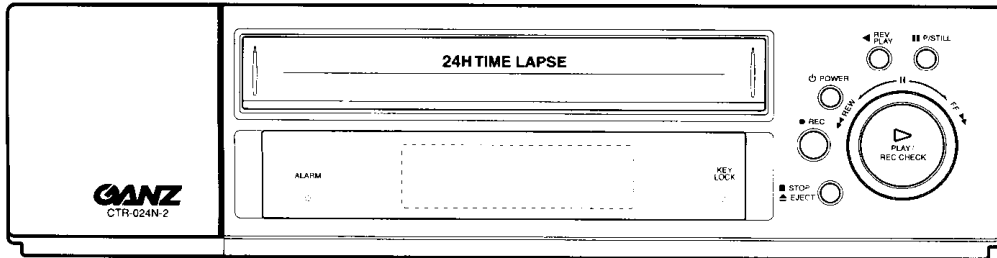

Contents

Introduction

| | |
|----------------------|---|
| Intended Use | 3 |
| Identification Plate | 3 |

Safety Measures

| | |
|-----------------------------|---|
| Electrical hazards | 4 |
| Installation | 4 |
| Maintenance and Repair | 4 |
| Operation | 4 |
| Symbols used in this manual | 4 |

Product Description

| | |
|--|---|
| Items Supplied | 5 |
| Recommended Accessories | 5 |
| Main functions in brief | 5 |
| Operating controls and display functions | 6 |

Operation

| | |
|----------------------------------|----|
| On/Off | 8 |
| Handling your videocassettes | 9 |
| Playback | 10 |
| Search functions | 11 |
| Tape Counter | 12 |
| Image Sharpness | 12 |
| Recording | 13 |
| Alarm recall list | 15 |
| Power Cuts | 16 |
| Text display position adjustment | 16 |

Installation

| | |
|-----------------------------|----|
| Connections on back of unit | 17 |
| Preparations | 18 |
| Connecting peripherals | 18 |
| Switching contacts | 19 |

Programming

| | |
|-----------------------|----|
| Basic operation | 21 |
| Language selection | 22 |
| VCR SET UP menu | 23 |
| REC MODE SET UP menu | 24 |
| TIMER REC SET UP menu | 25 |
| ALARM SET UP menu | 26 |
| Keypad locked | 27 |
| Default settings | 27 |

Care and maintenance

| | |
|--------------------------------------|----|
| Cleaning the unit | 28 |
| Cleaning the recording/playback head | 28 |
| Regular inspections | 28 |
| Fuse replacement | 28 |
| Battery replacement | 28 |

Appendix

| | |
|---|----|
| Connection in series of several video recorders | 29 |
| Troubleshooting | 30 |
| Error codes | 30 |
| Technical specifications | 31 |
| Resale, disposal | 31 |

These Installation and Operating Instructions, (edition 06/2003) are for use with the CTR-024N-2 time-lapse VCR (year 2003 model)

Introduction

These installation and operating instructions are designed for the use of anyone concerned with the setting-up or day-today use of the unit. All persons involved in carrying out installation work (i.e. qualified electricians or service engineers), must ensure that they are familiar with the unit's electrical and electronic systems and should follow the applicable safety rules and other relevant legislation at all times.

Intended Use

The CTR-024N-2 time-lapse VCR is designed for professional use as part of a video surveillance system. The purpose of the unit is to provide recording and playback of video images on standard videocassettes in either real time or time-elapsd mode.

The installation and maintenance of this unit should be carried out by qualified electrical service technicians only.

If you have any queries that are not covered by this manual, please contact the supplier at:

Identification Plate

Precise identification of each device is provided by the plate fixed to the rear of the unit, which shows its model designation and serial number. Please copy these details into the box below. This will ensure that you have the required data to hand if a query arises or whenever you need to order spares.

Model:

Serial number:

This equipment has been tested and found to comply with the limit for a Class A digital device, pursuant to part 15 of the FCC Rules. These limits are designed to provide reasonable protection against harmful commercial environment. This equipment generates, uses, and can radiate radio frequency energy and, if not installed and used in accordance with the instruction manual, may cause harmful interface to radio communications. Operation of this equipment in a residential area is likely to cause harmful interface in which case the user will be required to correct the interface at his own expense.

TIME LAPSE SUPPLY

888.590.9923 Toll-Free

www.timelapsesupply.com
info@timelapsesupply.com

415.380.9099 Phone
 415.380.9088 FAX

THIS DEVICE COMPLIES WITH PART 15 OF THE FCC RULES. OPERATION IS SUBJECT TO THE FOLLOWING TWO CONDITIONS :
 (1) THIS DEVICE MAY NOT CAUSE HARMFUL INTERFERENCE, AND (2) THIS DEVICE MUST ACCEPT ANY INTERFERENCE RECEIVED, INCLUDING INTERFERENCE THAT MAY CAUSE UNDESIRED OPERATION.

Safety Measures

Electrical hazards

- Ensure that the VCR and all associated ancillary equipment are connected to a suitable mains network power supply.
- Disconnect the VCR from the power supply (and from all other devices) immediately if the presence of smoke or an acrid smell suggests that a malfunction has occurred.
- Disconnect the VCR from the power supply (and from all other devices) immediately in the event of a fault arising.
- Always disconnect the unit from the power supply before opening its housing.
- Please note that only suitably qualified electrical technicians are authorised to carry out installation or servicing work on this unit.
- If you intend to take the VCR out of service for an extended period, disconnect it from the power supply and ensure that it is stored in a dry, weather-protected location.
- Do not allow liquids of any type to get inside the unit (e.g. by placing a full container on top of the device, or when cleaning).
- If liquid does enter the housing, shut the unit down at once and have it examined by the installer or a qualified service technician.
- Take care to ensure that no cable or wire fitted to the unit becomes pinched, trapped or otherwise damaged. Replace any damaged wiring at once.
- If hazard-free operation of the unit cannot be guaranteed, take it out of service immediately and ensure that it cannot be reconnected by accident.

Hazard-free operation is no longer possible in the following situations (among others):

- visible damage to the housing or wiring,
- objects have been inserted,
- after long-term storage in unfavourable conditions (e.g. damp) or after particularly rough handling during transport.

Have the unit examined by CBC then.

Installation

- The installation tasks described in this manual are to be carried out by adequately trained electrical technicians only, who should ensure that relevant electrical standards and legislation are observed at all times.
- Any modifications to the unit are likewise the exclusive preserve of trained electrical specialists.

Maintenance and Repair

- All maintenance and repair operations should be carried out by trained electrical specialists only.
- Unauthorised repairs can lead to personal injury, material damage or harm to the unit itself.

Operation

- Operate this unit strictly according to the instructions contained in this manual.
- Unauthorised operation can lead to personal injury, material damage or harm to the unit.

Symbols used in this manual

The safety instructions given in this manual are classified into two groups:



DANGER of electric shock

Failure to observe safety warnings identified with this symbol can lead to electric shock injuries. The symbol is used to identify immediate hazards.



Caution

This symbol identifies hazards likely to cause harm to the unit itself or other material damage.

You will also find instructions designed to simplify the operation of the unit:



Note

This symbol is used to identify special operating features of the unit.

Product Description

Items Supplied

- 1 CTR-024N-2 time-lapse VCR
- 1 Installation and operating instructions

Recommended Accessories

- All cameras should operate on standard EIA or NTSC video signals
- All monitors should be suitable for receiving these EIA or NTSC standard signals
- T-120 VHS videocassettes suitable for use with time-lapse VCR units



Note

Do not use "High Grade" videocassettes or those designed for entertainment use.

The use of T-160 VHS tapes specially designed for time-lapse VCR units is possible under exceptional circumstances. Ensure in this case that you take proper account of the altered running time of the cassette.

Main functions in brief

The CTR-024N-2 time-lapse VCR, which is designed for professional use as part of a video surveillance system, is configured for fast installation and ease of operation. All the main operating controls are easily accessed from the front panel of the unit. Menu-based programming is carried out using the on-screen display of the monitor that forms part of the system. The operating controls can be blocked with a key to prevent unauthorised or accidental activation or shutdown of the unit's functions.

Video and audio connections are provided by the standard sockets fitted to the back of the unit.

The display on the front of the device shows the usual VCR operating, running-time and tape position indications, along with all required information regarding operating status, active functions, recordings, malfunctions or alarms.

A terminal strip fitted to the back of the unit provides the connection point for any required alarm recording signals or the linking in cascade of various recorders. Alarm outputs are activated when the tape runs out or if a recording malfunction occurs.

The connection in cascade of various units permits continuous recording over an extended period, with each recorder in the sequence starting up automatically as soon as the tape in the preceding machine runs out.

A wide range of playback functions - such as search, slow motion, frame-by-frame forward wind and freeze-frame - are provided to ensure easy and efficient operation.

A concealed "Reset" button allows the video recorder to be returned to its default settings if required.

Operating controls and display functions

Front panel

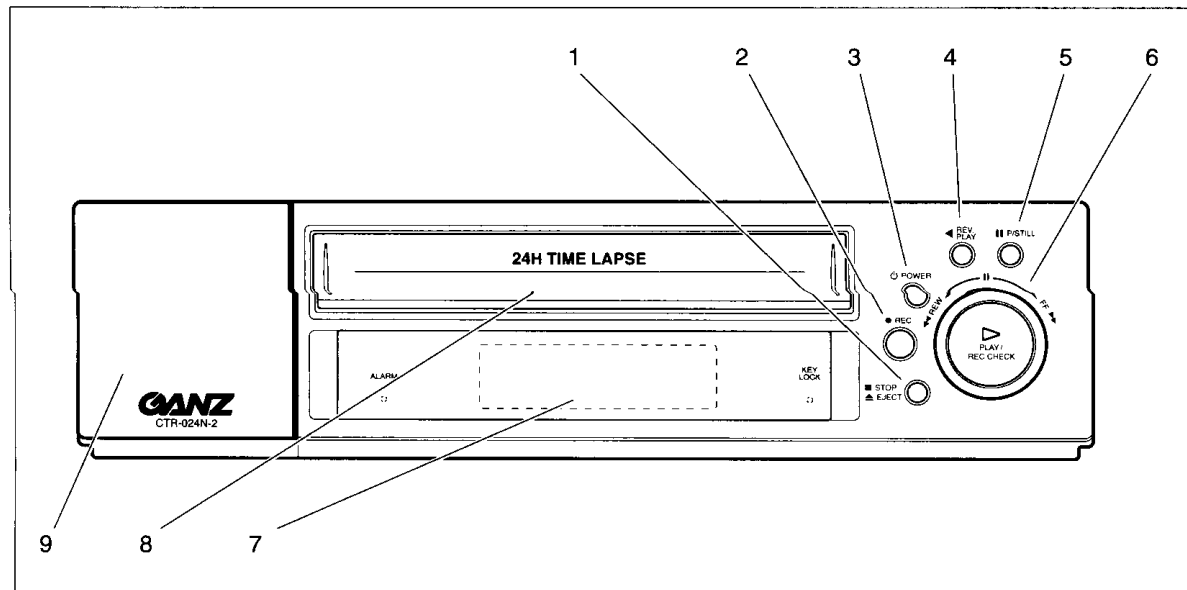

- 1 STOP/EJECT button**
for stopping tape and ejecting cassette
- 2 REC button**
for activating the manual recording function
- 3 POWER button**
for switching the unit on and off
- 4 REV. PLAY button**
for reproduction in tape rewind mode
- 5 P/STILL button**
for pausing the tape during recording and for capturing a single image during playback (freeze-frame)

- 6 Shuttle control and PLAY button**
for running the tape in fast-forward or rewind mode, and for starting normal playback
- 7 Display**
for indication of operating data and other information
- 8 Cassette compartment**
for loading the videotape
- 9 Control panel**
for configuring, adjusting and programming the unit

Display

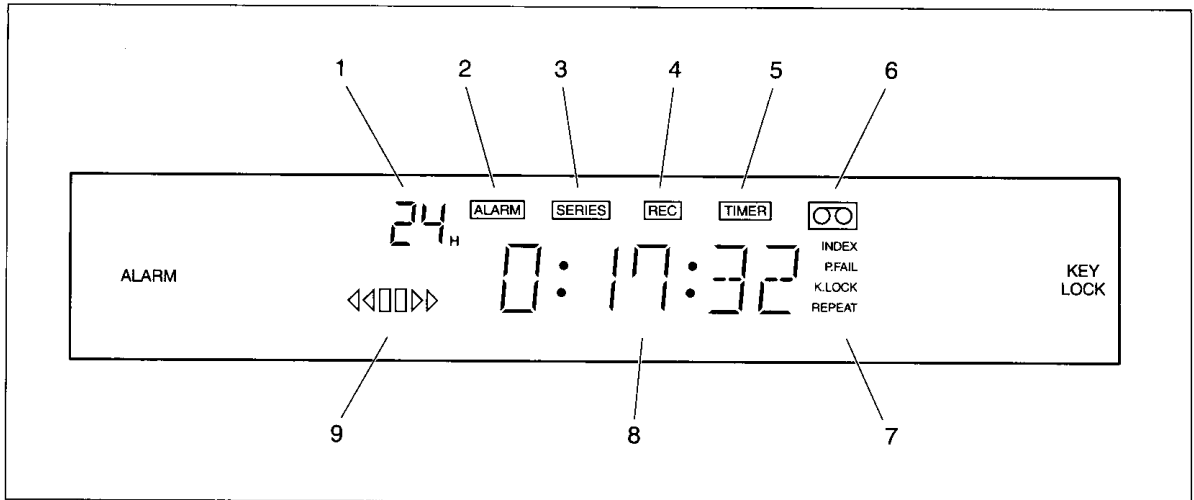
**1 Tape running time**

shows the tape running time currently selected:
2, 12 or 24 hours.

2 ALARM

lights up whenever the alarm-activated
recording function is running.

3 SERIES

lights up whenever various machines are
connected in cascade to provide continuous
recording.

4 REC

lights up while the unit is recording.

5 TIMER

lights up whenever the timed recording function
has been activated (by pressing the TIMER
button).

6 Cassette symbol

lights up whenever a tape is present in the
machine.

7 Status information**INDEX**

flashes while the alarm index search function is
active.

P.FAIL

lights up to indicate that the unit has restarted
after a power failure during operation.

K.LOCK

lights up to indicate that the operating controls
are blocked.

REPEAT

lights up when the tape runs out, indicating
automatic rewind and re-recording.

8 Counter

displays information according to the operating
mode selected: time, tape position, total re-
cording head operating time, error numbers,
tape counter or tape remaining.

9 Tape running mode

indicates current tape function: fast rewind,
reproduction in rewind mode, pause, normal
playback or fast forward.

Operation

On/Off

Do not plug the video recorder into the power supply until all the required connections have been carried out and the unit has been checked for correct configuration and possible loose wiring.

Before operating the video recorder, ensure that the technician responsible has installed and programmed the unit correctly and that all functions are in full working order.



Note

The installer will normally carry out all the required machine programming operations before initial start-up. Further installation and programming instructions are provided elsewhere in this manual (from page 17 onwards).

You may find that the video recorder operating controls are blocked, making them inoperable (further information on page 27).

- If not already done, connect the video recorder to the power supply. The unit is now in standby mode, as indicated by the dimmed information display (showing time, etc.)
- Press the POWER button to activate the video recorder. The information shown will now change and the display will light up more brightly.
- Press the POWER button again to shut down the unit.

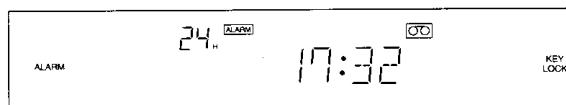
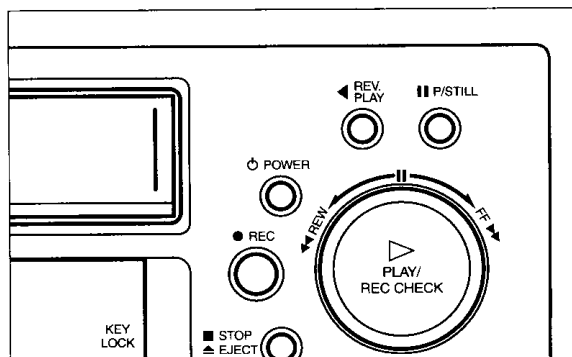

Handling your videocassettes

The videotapes used in time-lapse recording units are subjected to particularly high levels of wear and tear. For this reason, ensure whenever possible that you use only T-120 cassettes that have been specifically designed for use in time-lapse video recording systems.



Note

Do not use "High Grade" videocassettes or those designed for entertainment use.

The use of T-160 VHS tapes specially designed for time-lapse VCR units is possible under exceptional circumstances, but ensure in this case that you take proper account of the altered running time of the cassette.

Take care to observe all the information given on the cassette packaging and note the following points:

- Protect the cassette from extremes of heat and damp, and from magnetic fields.
- Keep the protective cover shut at all times and never pull the tape out of the cassette or touch it with your fingers.
- Keep unused cassettes in their protective cases at all times.
- Do not tamper with the tape cassette mechanism.

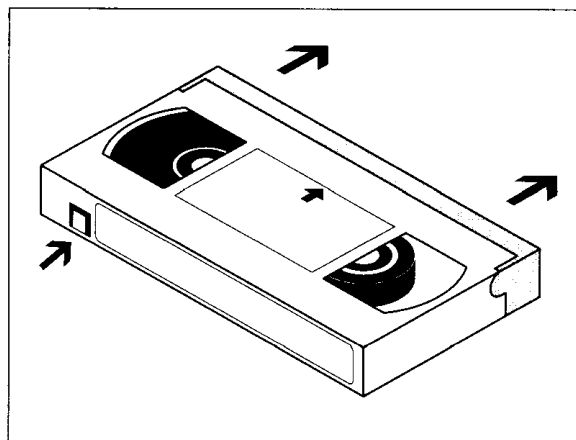

Recording protection

Proceed as follows to prevent tapes being wiped accidentally:

- After recording on the tape, snap off the small tab at the back of the cassette. The tape is now available for playback only, and will be automatically ejected from the machine whenever the REC button is pressed.
- If you wish to re-use this tape for recording at a later date, cover the hole left by the broken tab with a small length of adhesive tape.

Cassette loading and removal

Videocassettes are normally marked with an arrow on the top to indicate the direction of insertion in the machine.

Tapes can be loaded and ejected even when the unit is off. The video recorder switches on automatically when a cassette is inserted.

- Load the cassette (with the transparent window facing upwards and the tape-protection cover towards the machine) by pushing it gently into the tape compartment until it is taken up automatically.
- If the VCR is running, press STOP before ejecting the tape.
- Press the EJECT button, and the cassette will be pushed slowly out. Carefully remove the cassette completely.

Search functions

Visual search

You can operate the videocassette in rewind or fast-forward mode - with the image displayed on-screen - in order to help find a particular recorded scene.

- Press the PLAY button to activate the playback function.
- Turn the shuttle control briefly and then release it. Depending on the direction of rotation, the recorded image will now be reproduced in fast rewind or forward mode.
- Press the PLAY button to return to normal playback.



Note

The video recorder returns automatically from fast-search function to normal playback mode after three minutes to prevent excessive wear to the recording/playback head and tape.

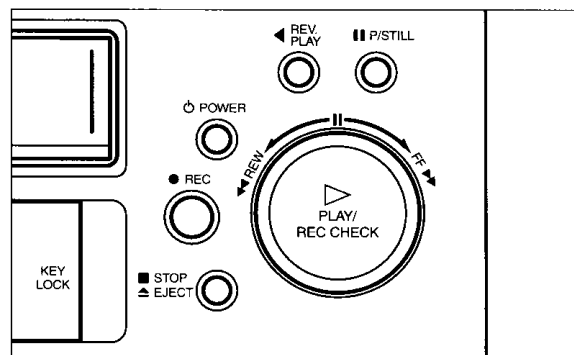

Search for alarm-activated recording (alarm index)

You can carry out a search in fast-forward or rewind mode to find particular alarm-activated recordings.

- If the machine is running, press the STOP button to halt the tape.
- Open the flap on the front of the unit and press the ALARM INDEX button. INDEX will now appear on the display.
- Turn the shuttle control briefly and then release it. The INDEX display will now begin to flash.

Whenever an alarm-activated recording is detected, approximately the first five seconds are reproduced in normal playback mode. The machine then winds on automatically to the following indexed recording.

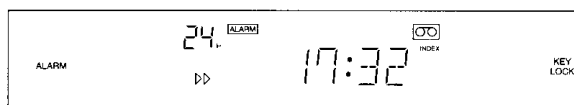
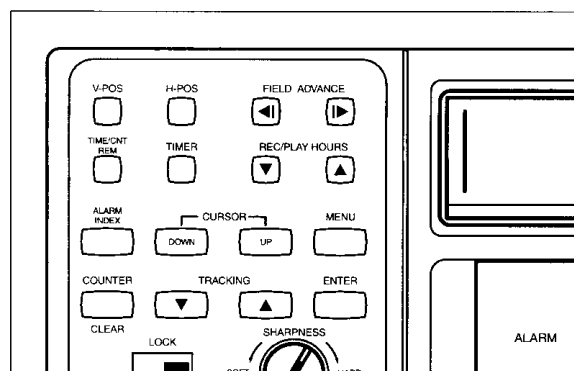

Tape Counter

It is possible to display the tape counter instead of the current time and \bar{n} during recording or playback \bar{n} the amount of tape remaining.



Note

The tape counter only works when the cassette contains recordings. It will not register unrecorded or blank sections of tape.

- To change from one display to another, open the flap on the front of the recorder and press the TIME/CNT/REM button. The display showing the amount of remaining tape is identified by a capital "R".
- Briefly press the COUNTER button to reset the counter during playback or recording.
- At the end of the current playback or recording operation, briefly turn the shuttle control anti-clockwise and then release it. The video recorder will now rewind the tape to the point where the counter was reset, where it will stop automatically.

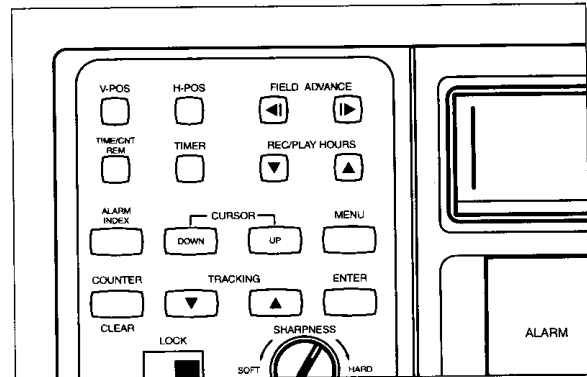

Note

The display returns automatically to its clock function whenever the cassette is ejected or the video recorder is switched off.

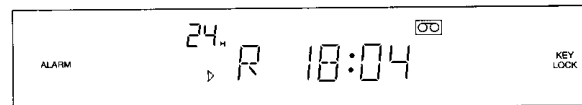
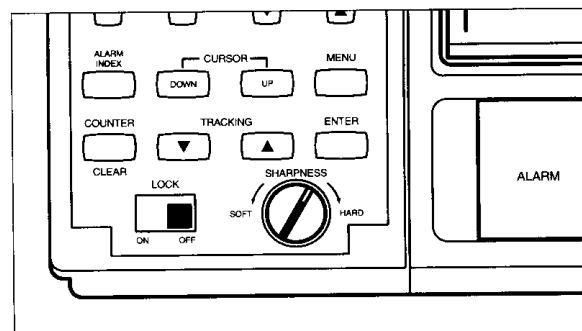

Image Sharpness

If necessary, you can adjust the level of sharpness (contrast) while the image is being reproduced.

- Open the flap on the front of the unit and turn the SHARPNESS control to increase or decrease the level of contrast.



Recording

This VCR unit can operate in various different recording modes:

- Manual
- Timer-activated
- Controlled by an external signal
- Alarm-activated
- Activated by other VCR units (recording in series)
- Automatic rewind and restart when tape runs out

Selection of an appropriate recording mode is normally carried out by the user of the system, with the recorder programmed as required or configured to run from an external signal source. For further information, please refer to the sections entitled **Installation** (page 17 onwards) and **Programming** (page 21 onwards).

Manual recording

You can start the manual recording function at any time, provided the machine is loaded with an unprotected cassette.

 **Note**
Recording may not begin immediately if you set the tape running time to "000". The actual reaction of the video recorder depends on how it has been programmed (see page 24).

- Activate the video recorder and monitor, if not already done.
- If not yet done, open the flap on the front of the recorder and press the arrow keys marked REC/PLAY HOURS to select the tape running speed for recording. The tape running time will now appear on the display (e.g. "24H").
- Press the REC button. Recording will now begin, and "REC" will appear on the display.
- Press the P/STILL button to pause the recording.
- If you wish to check for correct functioning, press the PLAY button while recording is taking place to display the previous few seconds of recorded tape. The system will then return automatically to normal recording.
- Press the STOP button to cancel the recording function.

 **Note**
The record-pause function shuts down automatically and stops the tape after five minutes to prevent excessive wear to the recording head and tape.

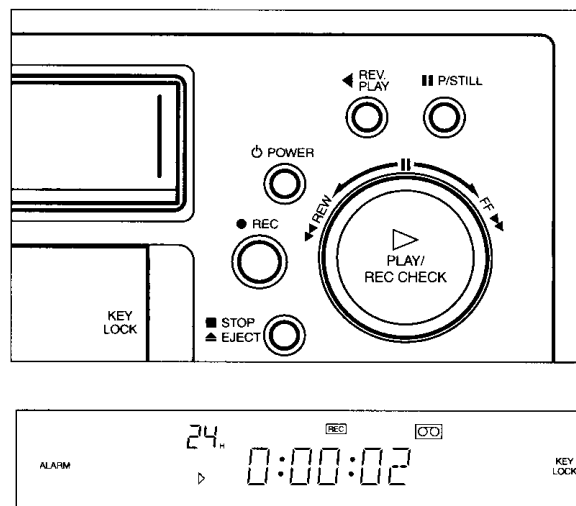

Timer-activated recording

This unit can be programmed with up to eight different timer-activated recording functions (see page 25).



Note

When programming the unit for timer-activated recording, ensure that the machine is loaded with a fully-rewound, unprotected tape cassette.

- Activate the video recorder and monitor, if not already done.
- Open the flap on the front of the unit and press the **TIMER** button. The recorder will now shut down automatically and "TIMER" will appear on the display.

When the pre-programmed start time is reached, the video recorder activates automatically and begins recording. Once the end of the pre-set time is reached, the unit stops recording and shuts down automatically.



Note

You cannot stop the recording function manually or switch the unit off while timer-activated recording is taking place.

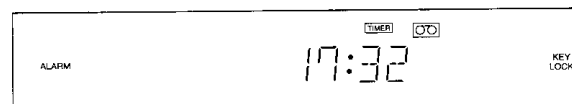
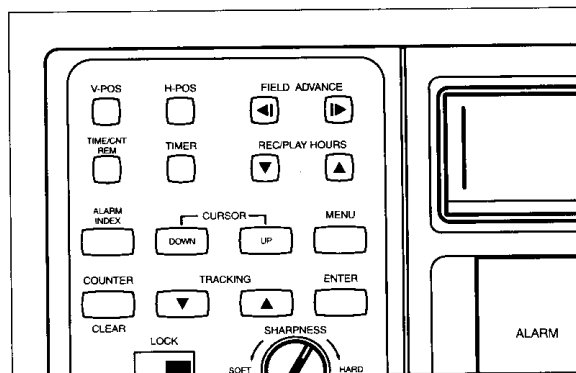

Alarm-activated recording

The alarm-activated recording function is activated by means of an external signal. Individual operating features depend on the type of installation (see page 19) and the programmed configuration (see page 21 onwards).

The **ALARM** indication is displayed whenever the alarm-activated recording function is programmed as active.

The red LED indicator under the **ALARM** sign flashes during an alarm-activated recording operation, accompanied - if required - by an audible signal tone.

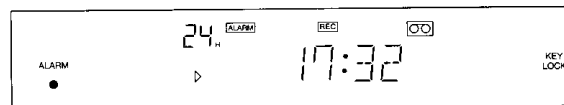
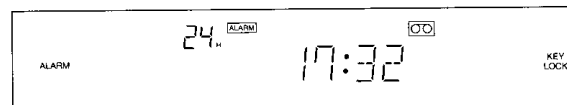

Series recording

Several video recorders can be connected in sequence, with the system programmed so that each recorder starts up automatically as soon as the tape in the previous machine in the sequence runs out. Individual operating features depend on the type of installation (see page 29) and the programmed configuration (see page 24).

The **SERIES** indication is displayed whenever the series recording function is programmed as active.

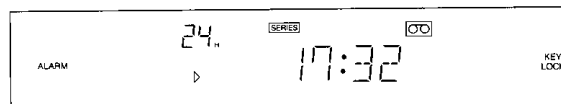

Automatic restart function

The video recorder can be programmed to rewind automatically as soon as the tape runs out and re-record on the same tape.

This automatic function can be overridden, after corresponding programming, in the event of an alarm arising (see page 24).

The REPEAT indication is displayed whenever the automatic restart function is programmed as active.

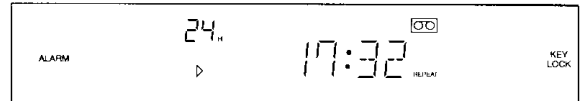

Recording function activated from external signal

The video recorder can be programmed to allow activation from an external signal source.

Note however that the recording function has to be started manually in this case.

The REC indication appears on the display, along with a tape running time of 000H.

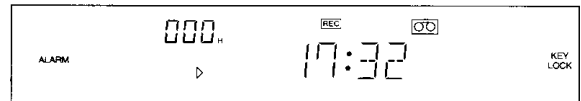

Alarm recall list

This feature allows you to display a list of the last 16 alarm incidents, with the data shown in chronological order. Once there are more than 16 incidents, the oldest item is automatically deleted.

- Stop the machine if it is still recording.
- Open the flap on the front of the unit and press the MENU button. This will display the main menu.
- Press the DOWN button repeatedly until ALARM SET UP is marked, then press the ENTER button.
- Press the DOWN button repeatedly until ALARM RECALL is marked, then press the ENTER button. The alarm recall list will now be displayed.
- Press the DOWN button repeatedly once more if you wish to display any further entries.
- Press the CLEAR button to delete the marked entry.
- Finally, press the MENU button repeatedly until the menu disappears from the display.

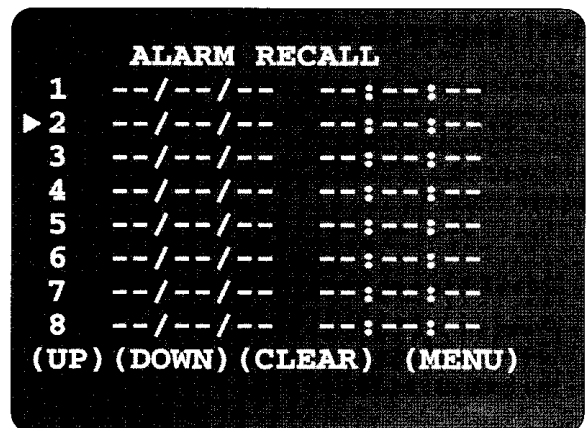
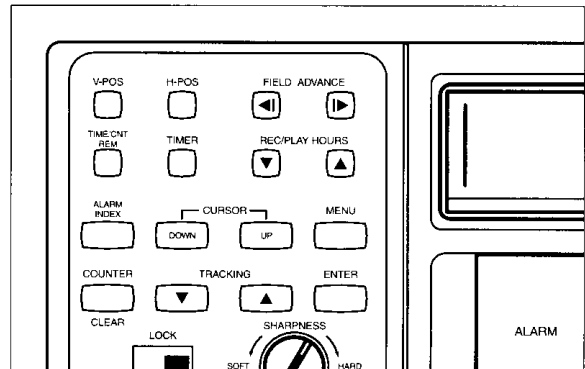

Power Cuts

The video recorder detects power cuts and logs each incident along with the corresponding date and time, showing you when each power failure began and ended. P.FAIL on the display indicates that a power cut has occurred while the video recorder was active.



Note

Power cuts with a duration of under one second are not registered. Automatic restart of the recording function is no longer possible if the power cut in question lasts longer than five minutes.

You can display a list of the last eight power cuts, with the data shown in chronological order.

- Stop the machine if it is still recording.
- Open the flap on the front of the unit and press the MENU button. This will display the main menu.
- Press the DOWN button repeatedly until POWER FAIL INFORM is marked, then press the ENTER button. This will display a list of detected power failures.
- Press the DOWN button repeatedly once more if you wish to display any further entries.
- Press the CLEAR button to delete the marked entry.
- Finally, press the MENU button repeatedly until the menu disappears from the display.

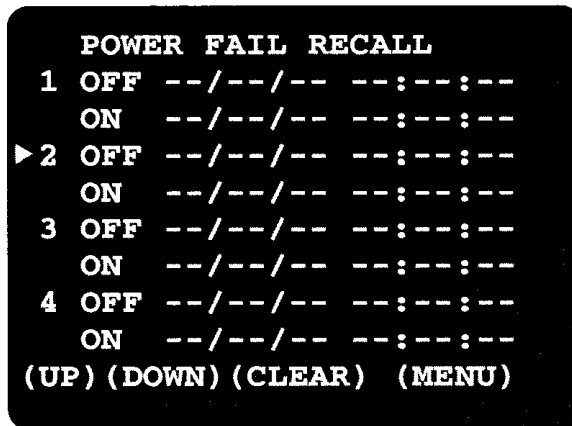
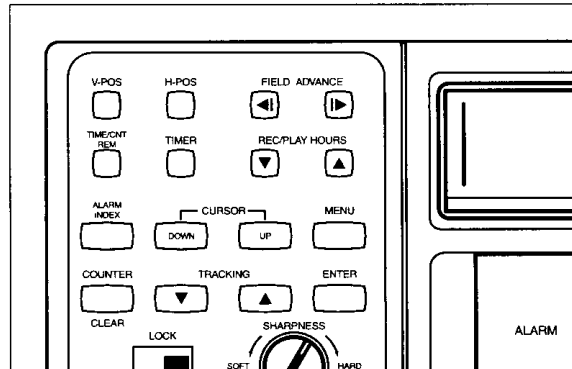
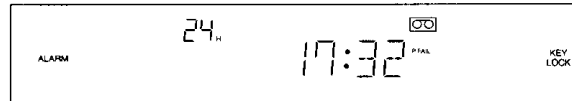

Text display position adjustment

Depending on the type of programming, the monitor will display the date, time and tape running time. You can displace these text displays for the purpose - for example - of making certain areas of the screen easier to see.

- Open the flap on the front of the recorder.
- Press the V-POS and H-POS buttons repeatedly until the texts begin to move. Position and order the texts as required.

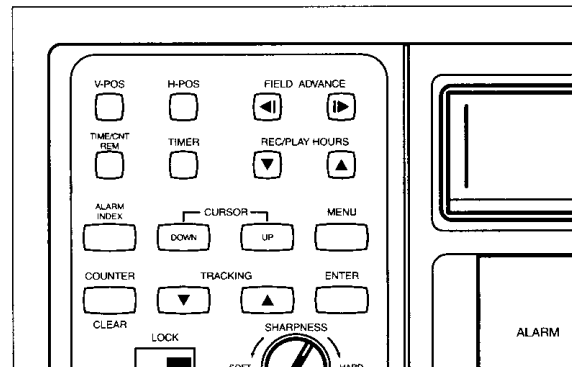

Installation

Connections on back of unit

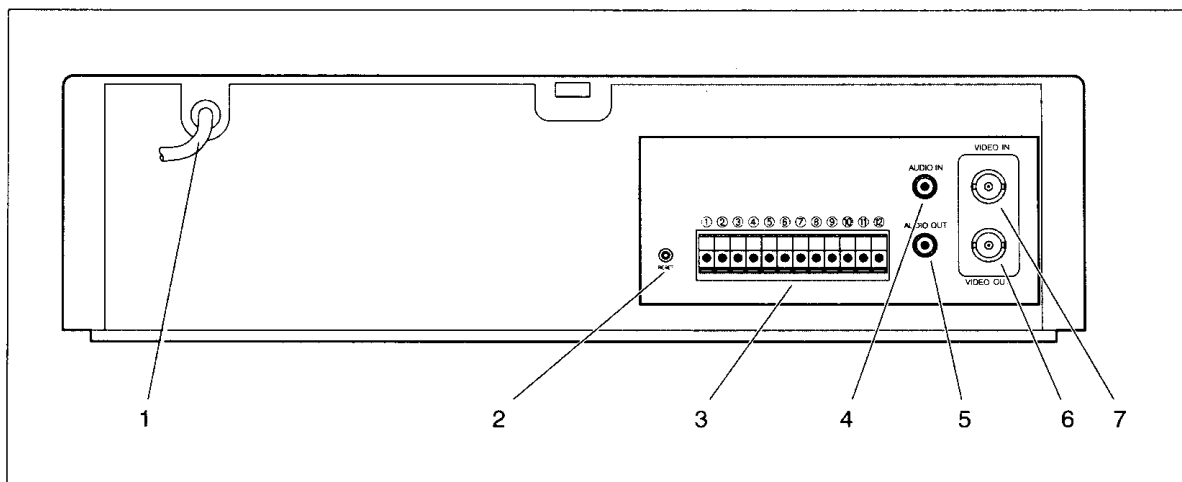

- | | |
|--|--|
| <p>1 Mains network power cable for connecting the unit to the power supply (via a suitably fused plug)</p> <p>2 RESET button for returning the video recorder to its default settings</p> <p>3 Activation in/out connection points alarm output and input, control pulse output and further signal inputs and outputs</p> | <p>4 AUDIO IN (cinch socket) for connection of an audio signal (e.g. from a multiplexer)</p> <p>5 AUDIO OUT (cinch socket) for connection auxiliary audio reproduction equipment (e.g. monitor equipped with loud-speaker)</p> <p>6 VIDEO OUT (BNC) for connection a monitor or additional video recorders</p> <p>7 VIDEO IN (BNC) for connection of a multiplexer or camera</p> |
|--|--|

Preparations



Caution

Ensure that you select an installation site that will not be subject to extreme temperatures or excessive damp. The surrounding temperature must lie with a range of 5 to 35°C, with relative air humidity less than 80 %.

Do not set the unit up in the immediate vicinity of heaters or radiators, and avoid installation sites with direct sunlight.

Ensure that the area around the unit is correctly ventilated.

Install the unit on a firm and stable flat surface, which should be of sufficient size to carry additional items of equipment such as multiplexers and monitors.

Connecting peripherals

Monitor

You can connect a monitor to the video recorder directly. The monitor displays either images supplied via the VIDEO IN socket, or reproduced recorded images.

The monitor also displays the on-screen menus used for configuring and programming the unit.

- The VIDEO OUT socket provides a link, via a BNC cable, to the VIDEO IN socket of the monitor.

Multiplexer or camera

You can connect a camera, a multiplexer or any other source of video signals to the video recorder. The recorder accepts the signals from the corresponding video source without processing them in any way.

- The camera or multiplexer is linked to the VIDEO IN socket via a BNC cable.

Audio

The video recorder is fitted with both AUDIO IN and AUDIO OUT sockets.

- The AUDIO IN socket is used to provide a link with the audio output of the multiplexer.
- The AUDIO OUT socket is used - for example - to provide a link with the audio input of the monitor.

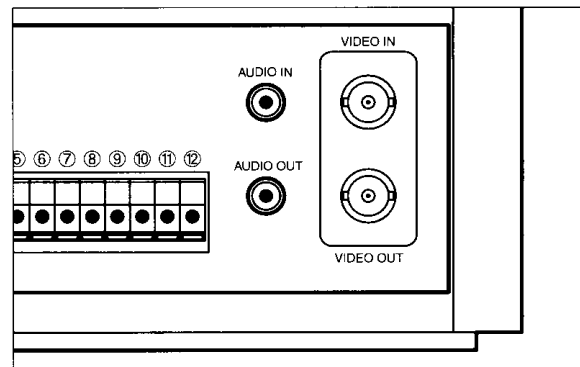

Switching contacts

The switching contacts can be used for controlling both the video recorder itself and a range of different peripheral items.

The contacts are laid out as follows:
high: 4 - 5 V, low: 0 - 0.6 V.

The table shows the configuration of the terminal strip:

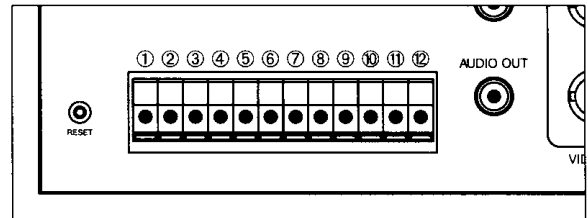

| Contact | Description | Function | Signal direction | Switching duration |
|---------|---------------|------------------------------|------------------|---------------------------|
| 1 | ALARM IN | Alarm for starting recording | IN | min. 250 ms |
| 2 | ALARM OUT | Alarm signal (e.g. horn) | OUT | duration of alarm |
| 3 | ALARM RESET | Clears alarm | IN | min. 250 ms |
| 4 | GND | Ground (earth) | - | - |
| 5 | SERIES IN | Connection in series | IN | min. 250 ms |
| 6 | SERIES OUT | Connection in series | OUT | min. 250 ms |
| 7 | WARNING OUT | Malfunction warning | OUT | until a button is pressed |
| 8 | TRIGGER OUT | Multiplexer timing signal | OUT | min. 8ms |
| 9 | GND | Ground (earth) | - | - |
| 10 | LOW TAPE OUT | low tape warning | OUT | 5 min. before end of tape |
| 11 | 1-SHOT REC IN | Start of recording | IN | min. 250 ms |
| 12 | GND | Ground (earth) | - | - |

1 ALARM IN

When the video recorder is configured accordingly, the purpose of 1 ALARM IN is to start the recording function automatically in the event of an alarm occurring.

2 ALARM OUT

The purpose of 2 ALARM OUT is to pass the alarm signal on, as a horn signal, for example. This contact remains active for the entire duration of the alarm-activated recording operation.

3 ALARM RESET

The purpose of 3 ALARM RESET is to clear the alarm and end the alarm-activated recording operation. When this function activates, recording stops and the audible alarm tone is shut off.

5/6SERIES IN/OUT

The purpose of the contacts designated 5 SERIES IN and 6 SERIES OUT is to allow the connection in series of various video recorders. Individual details of these features are described in the appendix (page 29).

7 WARNING OUT

The purpose of 7 WARNING OUT is to activate a warning signal in the event of a malfunction (e.g. a damaged tape cassette) and prevent recording.

8 TRIGGER OUT

The purpose of control pulse output 8 TRIGGER OUT is to provide a connection to a corresponding multiplexer input (CLOCK IN, CONTROL IN or TRIGGER IN). This clock pulse connection is used for synchronising the recording status of the VCR with the video signal transfer function of the multiplexer. This guarantees - for example - that no images are lost if there is a brief recording function start-up delay.



Note

Always use the control pulse output whenever possible, as the video recorder timing signal ensures the smooth synchronisation of the VCR and multiplexer.

10 LOW TAPE OUT

The function of 10 LOW TAPE OUT is to activate a warning signal when the tape is running out. The signal is activated when the tape has about five minutes left to run.

11 1-SHOT REC IN

The purpose of 11 1-SHOT REC IN is to permit remote activation of the single-image recording feature (see pages 13 and 24).

The connections are configured as screw-free plug-in terminals.

- Strip about 10 mm of insulation from the end of each connection wire.
- To release the terminal strip locking mechanism, insert a small screwdriver as far as possible into the slot beneath the corresponding terminal.
- Insert the bare end of the wire into the terminal and withdraw the screwdriver.
- Carry out a final check for loose wires.

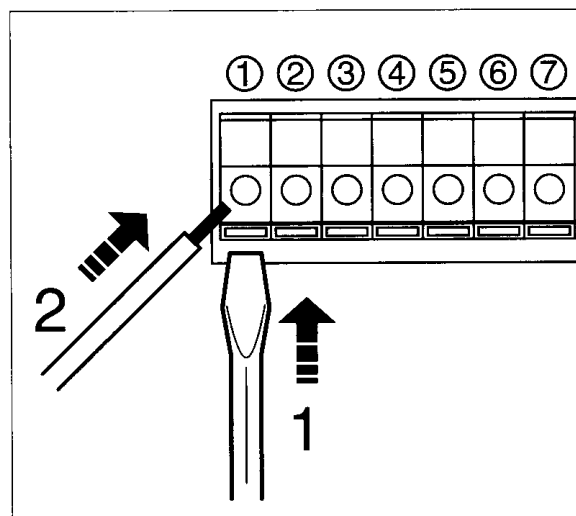

Programming

Check before starting the programming procedure that all peripheral devices (multiplexer, monitor, external alarm signal source) are properly connected.

The video recorder and all ancillary equipment must be switched on.



Note

Access to the menus is blocked when recording is in progress (indicated by "REC" on the display).

Basic operation

Control buttons

The various functions of the video recorder are simple to program thanks to the on-screen menu-based system. Menu entries are made using the control buttons located behind the flap on the front of the unit.



Note

If the menus on your particular machine differ from those described here, it is possible that a different version of the software has been installed. (Please refer to version information on the rear of the pack).

Menu navigation is carried out using just the following buttons:

- MENU** for activating the on-screen menu, for moving up one level within the menu, for cancelling the menu
- UP/DOWN** for moving from one menu item to another
- ENTER** for changing to the marked menu for altering settings
- CLEAR** for deleting an entry

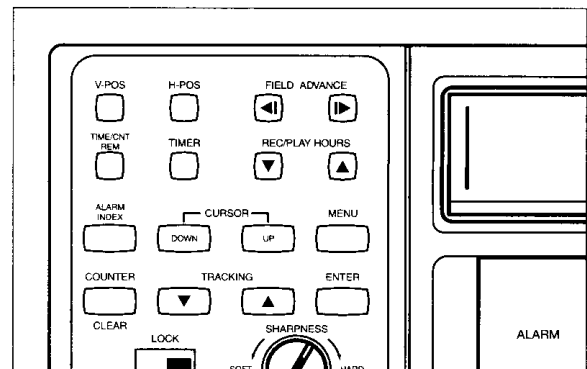

Starting and ending the programming procedure

Once the unit is switched on, the camera image will be displayed on the monitor and programming can begin.

- Stop the machine if it is still recording.
- Press the MENU button to display the main menu. The bottom line of each menu lists the buttons that can be used to continue programming.
- Finally, press the MENU button repeatedly until the menu disappears from the display.

If no entries are made, the menus will be cancelled automatically after a short time.

Marking and selecting

A small triangle indicates which menu item is currently selected.

- Use the UP or DOWN buttons to change this selection.
- Press the ENTER button to access the active menu or select one of the available parameter options.
- Press the MENU button again to return to the previous menu.

Note



Work systematically through the programming procedure, carrying out all the operations corresponding to each menu before moving on to the next.

Saving your settings

All menu configuration changes enter into effect either immediately or as soon as the menu disappears from the display. There is no need for a special configuration saving procedure.

Note



The following section describes all menus in the same order in which they are accessed from the main menu.

Language selection

You can select the language among English, Français, Deutsch, Italiano, Español, Polski and Japanese.

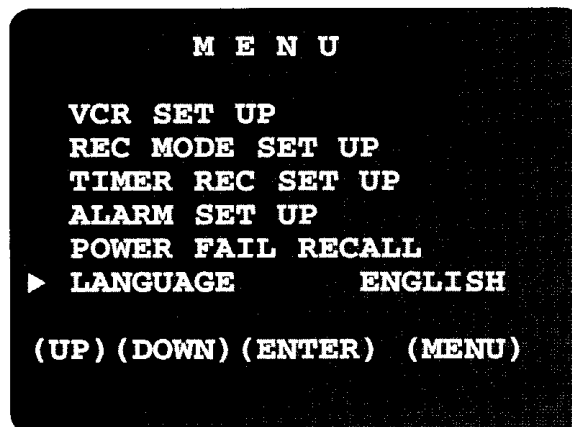
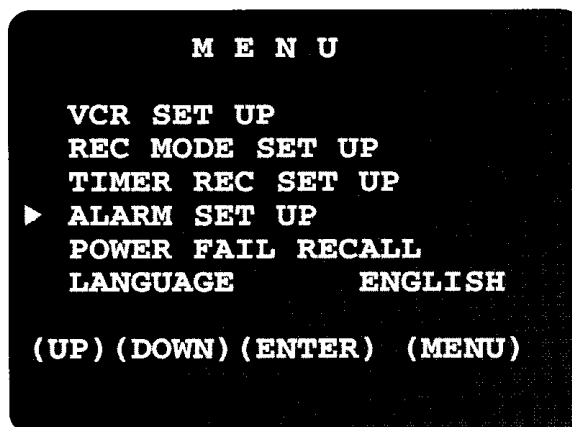
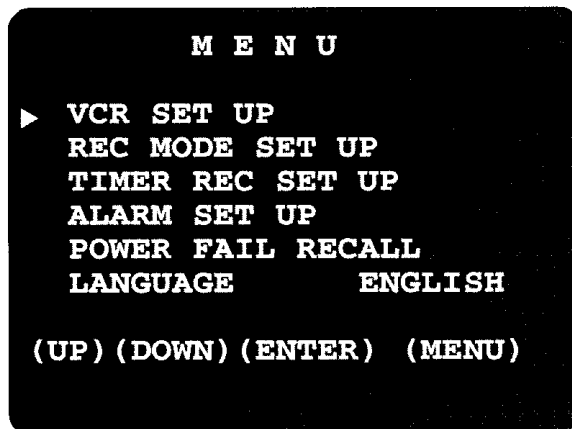

VCR SET UP menu

This menu allows you to carry out various adjustments to the basic VCR configuration, as described below.

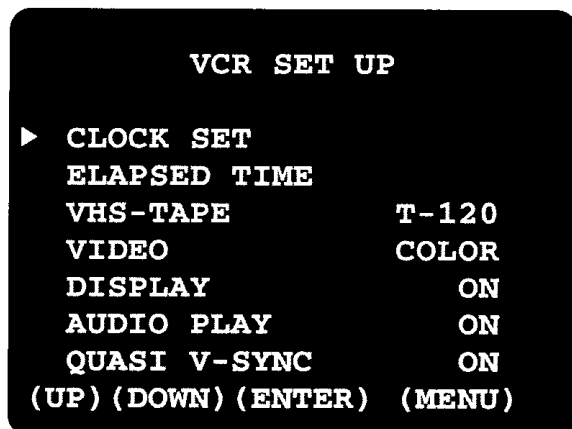

CLOCK SET

The internal calendar/clock settings need to be correct in order to permit the proper functioning of other programmed features, such as timer-activated recordings.

Note that the date and time formats may not coincide with those normally used in your country.

Possible settings:

| | |
|------|--------------|
| DATE | Today's date |
| DD | Day |
| MM | Month |
| YY | Year |
| TIME | Current time |
| HH | Hours |
| MM | Minutes |
| SS | Seconds |

ELAPSED TIME

This feature allows you to read the total operating time of the recording/playback head (no configuration changes possible).

| | |
|-------------------|--------------------------|
| DATE OF FIRST USE | Date of initial start-up |
| PERIOD IN USE | Operating time |
| HOURS | Total hours |

VHS-TAPE

Allows you enter details of the type of videocassette you wish to use.

Possible settings:

T-120
T-160
T-180
T-210

VIDEO

This feature allows you select the video recording quality. Note that image resolution is higher in the case of VHS-format monochrome recordings.

| | |
|-------|----------------------------------|
| COLOR | for color operation |
| B/W | for monochrome operation |
| AUTO | for color / monochrome operation |

DISPLAY

This feature allows you to use the monitor to show user information on the date, time and selected tape running time.



Note

Disable the text display feature if the unit is in use with a multiplexer, otherwise the information text from the various connected devices will overlap and obstruct a large part of the screen area.

| | |
|-----|-------------------------------|
| ON | Text display feature enabled |
| OFF | Text display feature disabled |

AUDIO PLAY

Allows you to choose whether to play recordings with or without sound.

| | |
|-----|----------------|
| ON | Sound enabled |
| OFF | Sound disabled |

QUASI V-SYNC

This feature allows you to switch Quasi V-sync for compatibility with Video Multiplexer.

| | | |
|-----|--------------|-----|
| ON | Quasi V-sync | ON |
| OFF | Quasi V-sync | OFF |

REC MODE SET UP menu

This menu allows you to carry out various adjustments to recording parameters, as described below.

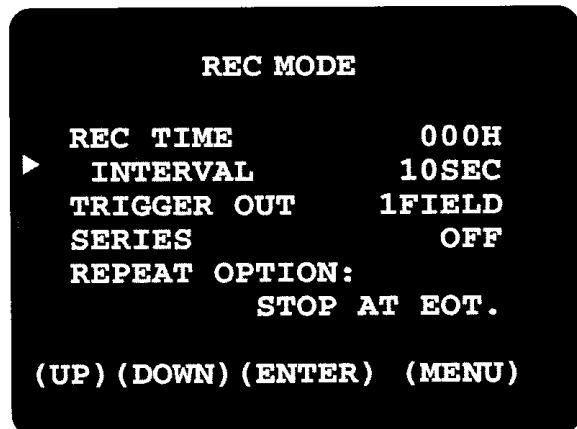

REC TIME

This feature allows you to pre-select the tape running time for the recording function. If you choose the 000H setting, further adjustments can be carried out in the new menu item designated INTERVAL.

Possible settings:

| | |
|------|--|
| 2H | 2 hours |
| 12H | 12 hours |
| 24H | 24 hours |
| 000H | Recording mode for 1-Shot REC function |

INTERVAL

With a tape running time of 000H selected, you can define recordings carried out using the 1-SHOT REC input terminal (see pages 13 and 20), adjusting the time interval applied to single-image recordings. Select the AUTO option to record an image with each switch operation.

Possible settings:

| | |
|--------|------------------------------------|
| 10 SEC | 1 image every 10 seconds |
| 20 SEC | 1 image every 20 seconds |
| 30 SEC | 1 image every 30 seconds |
| 1 MIN | 1 image every minute |
| 2 MIN | 1 image every 2 minutes |
| 3 MIN | 1 image every 3 minutes |
| AUTO | 1 image for every switch operation |

TRIGGER OUT

This feature allows you to split the control pulse output signal, in order to slow down the cycle, e.g. when using a commutator.



Note

Always select the 1 FIELD parameter when using a multiplexer.

Possible settings:

- 1 FIELD
- 2 FIELD
- 5 FIELD
- 10 FIELD
- 30 FIELD
- 60 FIELD

SERIES

If you wish to carry out series recording with various VCR units connected in sequence, ensure that this parameter is set to "ON" (see page 14).

Possible settings:

| | |
|-----|---------------------------|
| ON | Series recording enabled |
| OFF | Series recording disabled |

REPEAT OPTION:

This feature allows you to decide how the VCR should react automatically when the tape runs out during recording.

STOP AT EOT.

The recorder shuts down as soon as the tape runs out.

RE-REC EVEN IF ALARM

The recorder rewinds the tape and begins recording once more, regardless of whether an alarm signal has been received.

REWIND. STOP

The recorder rewinds the tape before shutting down.

STOP IF ALARM

The VCR rewinds the tape, but does not re-record if an alarm signal has been received.

TIMER REC SET UP menu

| SET | DAY | START | END | SPD |
|-------|-----|-------|-------|-----|
| OFF | M-F | 00:04 | 01:04 | 2 |
| ▶ OFF | --- | --:-- | --:-- | 2 |
| OFF | --- | --:-- | --:-- | 2 |
| OFF | --- | --:-- | --:-- | 2 |
| OFF | --- | --:-- | --:-- | 2 |
| OFF | --- | --:-- | --:-- | 2 |
| OFF | --- | --:-- | --:-- | 2 |
| OFF | --- | --:-- | --:-- | 2 |

(UP) (DOWN) (ENTER) (MENU)

This feature allows you to program the unit to make timer-activated recordings. This is done by establishing a start-up, shutdown and tape running time for each day of the week.

You can also program in the same instructions for every day from Monday to Friday, the weekend only or all seven days of the week.

The system can handle up to eight different program settings.



Note

Press the TIMER button to enable the timer-activated recording function (see page 14).

Possible settings:

| | |
|-----|---------------------|
| ON | Program activated |
| OFF | Program disabled |
| MON | Monday |
| TUE | Tuesday |
| WED | Wednesday |
| THU | Thursday |
| FRI | Friday |
| SAT | Saturday |
| SUN | Sunday |
| M-F | Monday to Friday |
| S-S | Saturday and Sunday |
| DLY | daily |

Keypad locked

You can block the VCR operating controls (and therefore menu access) in order to prevent accidental or unauthorised operation of the unit. The video recorder does not respond to any control button while this feature is active.

- Move the switch marked LOCK to its ON position. The keypad is now blocked, "K.LOCK" appears on the display and the LED situated beneath the KEY LOCK sign lights up.

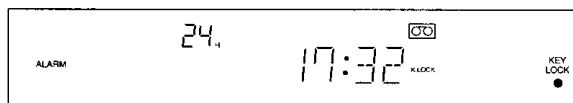
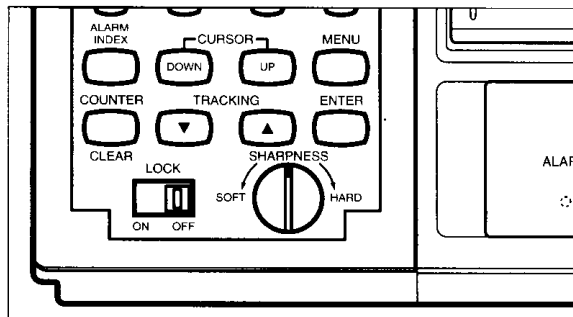

Default settings

You can return the video recorder to its default settings if, for example, you suspect that it has been programmed incorrectly or if the unit's operating circumstances have changed. The RESET button is located on the back of the unit.

- Press the RESET button with a ball-point pen or similar item. All user-defined program settings are now cancelled.
- Ensure before proceeding that all menu configurations and operating parameters correspond to your needs.

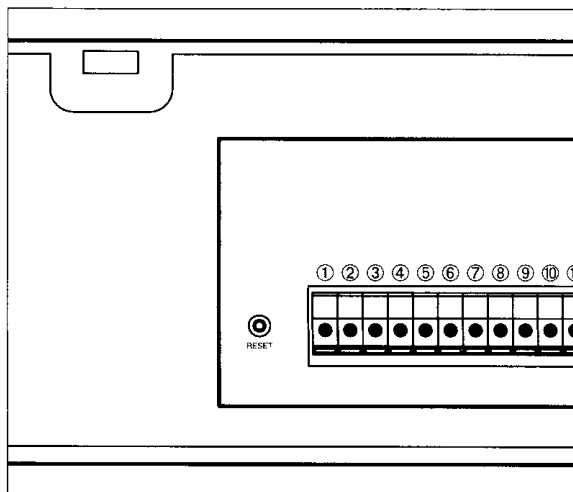

Care and maintenance

Cleaning the unit



DANGER of electric shock

Ensure that no liquid of any type is allowed to enter the unit. The entry of liquids into the housing can lead to fatal electric shock.

Wipe down the outside of the video recorder regularly with a soft damp cloth, using a neutral cleaning product to improve dirt-removing efficiency, if required.



Caution

Do not use abrasive or corrosive cleaning products or solvents, as they are likely to damage the surface of the unit.

Cleaning the recording/playback head

Thorough cleaning is required after every 1,500 hours of operation, although more frequent cleaning may be advisable under certain circumstances, such as after the regular use of old cassettes.

Use the VCR SET UP menu to read the current total operating hours of the recording/playback head (see page 23).



Caution

Clean the head using a special cassette designed for the purpose, carefully following the instructions supplied by the manufacturer of the head-cleaning tape. If in doubt, please contact the CBC Technical Service Department.

Regular inspections

This video recorder is a low-maintenance unit, designed to provide reliable long-term operation. It should however be subjected to a thorough inspection every 10,000 operating hours to guarantee its correct and trouble-free functioning. This inspection includes the testing of all mechanical parts and drive system components, with replacement as required.

All inspection work should be carried out by CBC's Technical Service.

Please contact your nearest CBC branch or authorised agent.



Caution

Do not attempt to carry out inspection work yourself and do not remove or try to replace any of the playback/recording head or drive system components, as this can result in serious damage to the video recorder.

Fuse replacement

The main internal fuse is not user-accessible. All blown fuses must be replaced by CBC's Technical Service when rectifying the corresponding fault.



Caution

Do not attempt to carry out fuse replacement yourself. If a malfunction occurs in the unit, it must be checked to ensure overall operating safety.

Battery replacement

The battery is permanently soldered into the unit. If you suspect that the battery is no longer charging correctly (e.g. frequent clock/date resets required) it must be replaced by CBC's Technical Service.



Caution

Do not attempt to replace the battery yourself, as this can result in serious damage to the video recorder.

Appendix

Connection in series of several video recorders

You can connect several CTR-024 N-2-type video recorders in series in order - for example - to increase recording capacity.

This requires the interlinking of various input and output connections of the units involved. You should also ensure that the series recording option is activated in the REC MODE menu (see page 24).

If the system is correctly installed and configured, each VCR starts to record automatically as soon as the tape in the previous unit in the sequence runs out.

Observe the following points when configuring the system for recording in series:

- All connected VCR units must be activated and ready to record.
- Each VCR should be loaded with a fully-rewound unprotected tape.
- The serial recording feature should be enabled for each VCR unit.

The diagram shows an example of the wiring

layout for three series-connected units.

- Link the VIDEO IN and OUT connections of all the VCR units involved to each other. Connect the VIDEO IN socket of the first recorder in the sequence to the video signal source (e.g. the multiplexer) and the VIDEO OUT socket of the last recorder in the sequence to the monitor.
- Connect together the ground (earth) points of each terminal strip.
- Connect the SERIES OUT contact of one VCR to the SERIES IN contact of the next recorder in the sequence.
- Connect the SERIES OUT contact of the last VCR in line to the SERIES IN contact of the first recorder in the sequence.
- Connect the ALARM OUT contact with the ALARM IN contact of the next recorder in the sequence.
- If required, connect the TRIGGER OUT control pulse outputs of all recorders to each other and to the control pulse input of the multiplexer.
- If required, connect the WARNING OUT sockets of all recorders to each other and to the external alarm signal (e.g. horn).

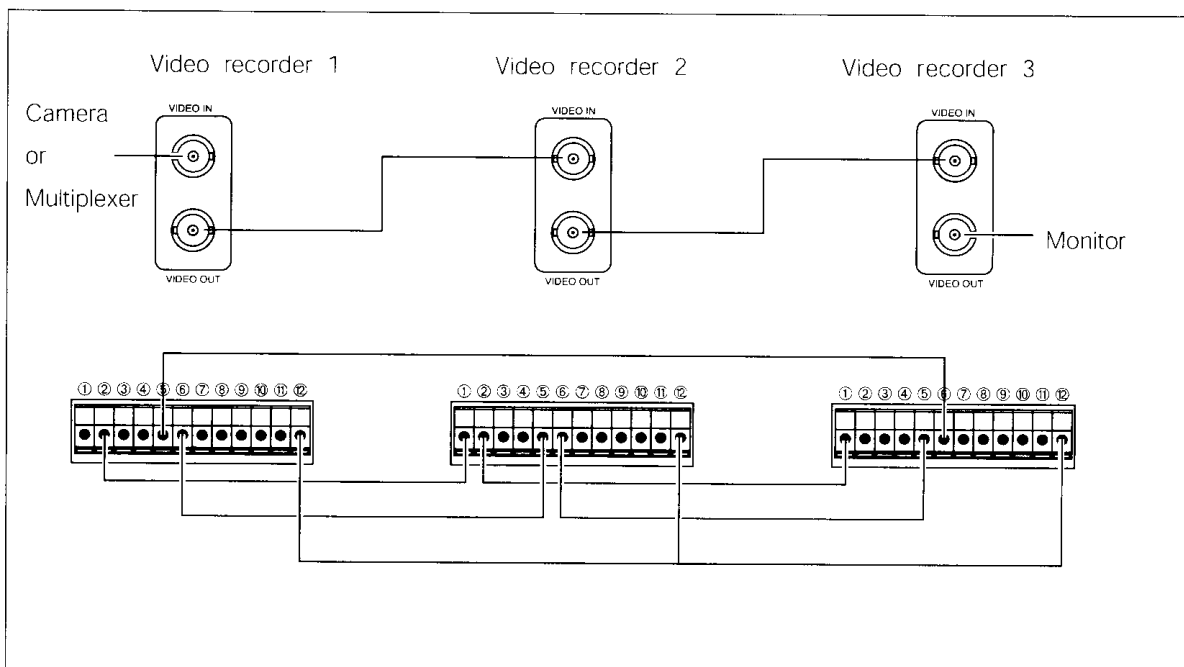

Troubleshooting

The purpose of the following table is to help you identify the cause of malfunctions and suggest possible remedies.

| Fault | Possible causes | Remedy |
|--|--|--|
| Cassette cannot be loaded and/or is not taken up by mechanism. | Cassette incorrectly aligned. | Turn cassette right way round and insert once more, ensuring that the transparent window is facing upwards and the tape-protection cover is pointing towards the recorder. |
| | There is already a cassette inside the video recorder. | Remove cassette. (by pressing STOP/EJECT button.) |
| | Video recorder not connected to power supply. | Check power supply connection, information display should light up dimly. |
| | Video recorder fails to start up automatically. | Switch video recorder on manually (by pressing POWER button.) |
| Device does not respond to control buttons. | Keypad blocked. | Turn LOCK switch to OFF Position to unlock keypad. |
| On-screen menus are not displayed. | On-screen menus cannot be displayed while unit is recording. | Stop recording function. |
| Recording function will not start. | Cassette record-protected. | Use another tape or disable protection by fixing adhesive tape over hole left by snapped-off tab on back of cassette. |
| Cassette is automatically ejected at the start of a timer- or alarm-activated recording operation. | | |
| No playback picture. | No recording on cassette. | - |
| | Faulty connection between video recorder and monitor. | Check connection lead. |
| | Monitor is off. | Switch monitor on. |
| Sound reproduction correct, but no image. | Recording/playback head dirty or misaligned. | Contact CBC's Technical Service Department. |
| Faulty image reproduction. | Tracking incorrect. | Press TRACKING button located under flap. Try with different cassette. If fault still cannot be remedied, contact CBC's Technical Service Department. |
| Flashing cassette symbol in display field. | No cassette in machine. | Load cassette. |

Error codes

Certain malfunctions cause an error code to appear in the display field.

| Error code | Possible cause | Remedy |
|------------|----------------------------------|---|
| E1 | Cassette-loading error | Remove cassette and insert once more. |
| E2 | | |
| E3 | Mechanical or drive system error | Repeat affected procedure, if fault still cannot be remedied, contact CBC's Technical Service Department. |
| E4 | | |
| E5 | | |

Technical specifications

| | |
|------------------------|--|
| Supply voltage | 100 - 240 V~, 50/60 Hz |
| Power consumption | 15 W (approx.) |
| Fuse rating | 250 V T, 1.6 A |
| Video system | NTSC System |
| Video input | 1 X BNC, VBS 1.0 Vp-p 75 Ohm |
| Video output | 1 X BNC, VBS 1.0 Vp-p 75 Ohm |
| Recording system | 4 heads, azimuth helical scan device |
| Rewind time | approx. 65 sec. (T-120 tape) |
| Signal-to-noise ratio | > 43 dB |
| Audio input | 1 X Cinch, -6.0 dB, >47 kOhm |
| Audio output | 1 X Cinch, -6.0 dB, <4.7 kOhm |
| Audio frequency range | 200 Hz - 10 kHz |
| Operating conditions | Temperature: 5 - 40 °C rel. air humidity: 80%, non-condensing |
| Storage conditions | Temperature: 0 - 50 °C If you intend to store the unit for longer than one month, add fresh desiccant and protect the device from moisture by packing it in a sealed container. |
| Dimensions (W X H X D) | 360 X 94 X 270 mm |
| Weight | 3.8 kg (approx.) |

Resale, disposal

If you sell or otherwise transfer ownership of the video recorder, be sure to hand it over along with these installation and operating instructions.

The video recorder contains environmentally harmful substances, so ensure that eventual disposal or scrapping is carried out according to the corresponding rules and legislation in this area.

Have defective or unserviceable units and components disposed of by a specialist waste-collection organisation, or ensure that they are consigned to your local special refuse facility.