

TIME LAPSE VCR

MODEL: CTR-030NC-2

OWNER'S MANUAL

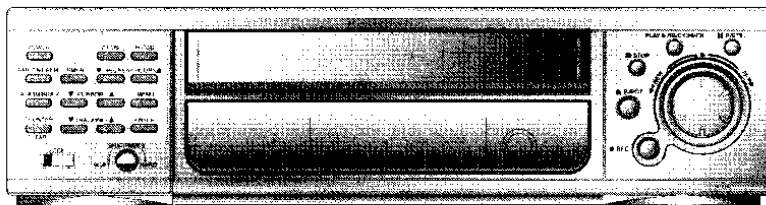

Before connecting, operating, or adjusting this product, please read this instruction booklet carefully and completely.

TIME LAPSE SUPPLY

888.590.9923 Toll-Free

www.timelapsesupply.com
info@timelapsesupply.com

415.380.9099 Phone
415.380.9088 FAX

TIME LAPSE

IMPORTANT SAFETY INSTRUCTIONS

CAUTION: PLEASE READ AND OBSERVE ALL WARNINGS AND INSTRUCTIONS IN THIS OWNER'S MANUAL, AND THOSE MARKED ON THE PRODUCT. RETAIN THIS BOOKLET FOR FUTURE REFERENCE.

This product has been designed and manufactured to assure personal safety. Improper use can result in electric shock or fire hazard. The safeguards incorporated in this product will protect you if you observe the following procedures for installation, use, and servicing.

This product does not contain any parts that can be repaired by the user.

DO NOT REMOVE THE CABINET COVER, OR YOU MAY BE EXPOSED TO DANGEROUS VOLTAGE. REFER SERVICING TO QUALIFIED SERVICE PERSONNEL ONLY.

- 1. Read these instructions.** - All these safety and operating instructions should be read before the product is operated.
- 2. Keep these instructions.** - The safety, operating and use instructions should be retained for future reference.
- 3. Heed all warnings.** - All warnings on the product and in the operating instructions should be adhered to.
- 4. Follow all instructions.** - All operating and use instructions should be followed.
- 5. Do not use this product near water.** - For example: near a bath tub, wash bowl, kitchen sink, laundry tub, in a wet basement; or near a swimming pool; and other areas located near water.
- 6. Clean only with dry cloth.** - Unplug this product from the wall outlet before cleaning. Do not use liquid cleaners.
- 7. Do not block any ventilation openings. Install in accordance with the manufacturer's instructions.** - Slots and openings in the cabinet are provided for ventilation and to ensure reliable operation of the product and to protect it from over-heating. The openings should never be blocked by placing the product on a bed, sofa, rug or other similar surface. This product should not be placed in a built-in installation such as a bookcase or rack unless proper ventilation is provided or the manufacturer's instructions have been adhered to.
- 8. Do not install near any heat sources such as radiators, heat registers, stoves, or other apparatus (including amplifiers) that produce heat.**
- 9. Do not defeat the safety purpose of the polarized or grounding-type plug.** A polarized plug has two blades with one wider than the other. A grounding type plug has two blades and a third grounding prong. The wide blade or the third prong are provided for your safety. If the provided plug does not fit into your outlet, consult an electrician for replacement of the obsolete outlet.
- 10. Protect the power cord from being walked on or pinched particularly at plugs, convenience receptacles, and the point where they exit from the product.**
- 11. Only use attachments/accessories specified by the manufacturer.**
- 12. Use only with the cart, stand, tripod, bracket, or table specified by the manufacturer, or sold with apparatus. When a cart is used, use caution when moving the cart/product combination to avoid injury from tip-over.**
- 13. Unplug this product during lightning storms or when unused for long periods of time.**
- 14. Refer all servicing to qualified service personnel. Servicing is required when the product has been damaged in any way, such as power-supply cord or plug is damaged, liquid has been spilled or objects have fallen into the product, the product has been exposed to rain or moisture, does not operate normally, or has been dropped.**



**WARNING : TO REDUCE THE RISK OF FIRE OR ELECTRIC SHOCK,
DO NOT EXPOSE THIS PRODUCT TO RAIN OR MOISTURE.**



CAUTION

RISK OF ELECTRIC SHOCK
DO NOT OPEN



CAUTION : TO REDUCE THE RISK
OF ELECTRIC SHOCK,
DO NOT REMOVE COVER (OR BACK);
NO USER-SERVICEABLE PARTS INSIDE
REFER SERVICING TO QUALIFIED SERVICE
PERSONNEL.

This lightning flash with arrowhead symbol within an equilateral triangle is intended to alert the user to the presence of uninsulated dangerous voltage within the product's enclosure that may be of sufficient magnitude to constitute a risk of electric shock to persons.



The exclamation point within an equilateral triangle is intended to alert the user to the presence of important operating and maintenance (servicing) instructions in the literature accompanying the product.



WARNING: Do not install this equipment in a confined space such as a bookcase or similar unit.

CAUTION: The apparatus should not be exposed to water (dripping or splashing) and no objects filled with liquids, such as vases, should be placed on the apparatus.

IMPORTANT COPYRIGHT INFORMATION: Many television programs and films are copyrighted. In certain circumstances, copyright law may apply to private in-home video taping of copyrighted materials.

MOISTURE CONDENSATION

If you pour a cold liquid into a glass, water vapor in the air will condense on the surface of the glass. This is moisture condensation. Moisture condensation on the head drum, one of the most crucial parts of the unit, will cause damage to the tape.

When the VCR is exposed to a rapid temperature change from cold to warm, some condensation will occur. Under this condition, connect the power cord to the AC line, press **POWER** button on and allow at least two hours for the VCR to dry out.

In case of using with a portable radio closely, the VCR may not operate normally.

FCC WARNING: This equipment may generate or use radio frequency energy. Changes or modifications to this equipment may cause harmful interference unless the modifications are expressly approved in the instruction manual. The user could lose the authority to operate this equipment if an unauthorized change or modification is made.

REGULATORY INFORMATION: FCC Part 15
This product has been tested and found to comply with the limits for a Class A digital device, pursuant to Part 15 of the FCC Rules. These limits are designed to provide reasonable protection against harmful interference when the product is operated in a residential installation. This product generates, uses, and can radiate radio frequency energy and, if not installed and used in accordance with the instruction manual, may cause harmful interference to radio communications. However, there is no guarantee that interference will not occur in a particular installation. If this product does cause harmful interference to radio or television reception, which can be determined by turning the product off and on, the user is encouraged to try to correct the interference by one or more of the following measures:

- Reorient or relocate the receiving antenna.
- Increase the separation between the product and receiver.
- Connect the product into an outlet on a circuit different from that to which the receiver is connected.
- Consult the dealer or an experienced radio/TV technician for help.

**CAUTION : TO PREVENT ELECTRIC SHOCK,
DO NOT USE THIS PLUG WITH AN EXTENSION
CORD, RECEPTACLE OR OTHER OUTLET
UNLESS THE PLUG CAN BE FULLY
INSERTED WITHOUT EXPOSING ANY PARTS
OF THE BLADES.**

The serial number is found on the back of this unit. This number is unique to this unit and not available to others. You should record requested information here and retain this guide as a permanent record of your purchase.

Model No. _____

Serial No. _____

FEATURES

- Time Lapse VCR Function
- Trigger Function
- Buzzer Function
- Auto Switcher Functionality
- Tape Compatibility
- Elapsed Time Display
- Series Recording Function
- Alarm Recording Function

CONTENTS

INTRODUCTION
Features/Contents 3

PREPARATION
Control Names and Locations 4-6
Installation/VCR to Monitor and CCD Camera
Connection 7
Multiplexer/Matrix Switcher Connections 8-9
Alarm Record Connection 10
Series Record Connection 10
Setting the On Screen Display 11
Setting the Setup Menu 12
Setting the Set Time 13
Video Cassette Tapes 14

PLAYBACK
Normal Playback 15
Special Effects Playback 16-17
Tape Counter Memory Feature 18

RECORDING
Normal Recording 19
Repeat Recording 20
Timer Recording 21
Series Recording 22
Alarm Recording 23-24

ADDITIONAL INFORMATION
Check the Alarm Record Information 25
Recording Time Table Information 25
Check the Power Fail Recall 26
Use to Lock On/Off Switch 26
Self-Diagnosis 27
Service Guide Table 28
VIDEO Head Cleaning 28
Troubleshooting 29
Specifications 30

Warning : The battery used in this device may present a fire or chemical burn hazard if mis-treated. Do not recharge, disassemble, incinerate, or heat above 212°F (100°C). Replace the battery with Matsushita Elec. Ind., Co., Ltd. (Panasonic) part no. VL2330 only. Use of another battery may present a risk of fire or explosion. Dispose of used batteries. Keep away from children. Do not disassemble or dispose of in fire.

CONTROL NAMES AND LOCATIONS

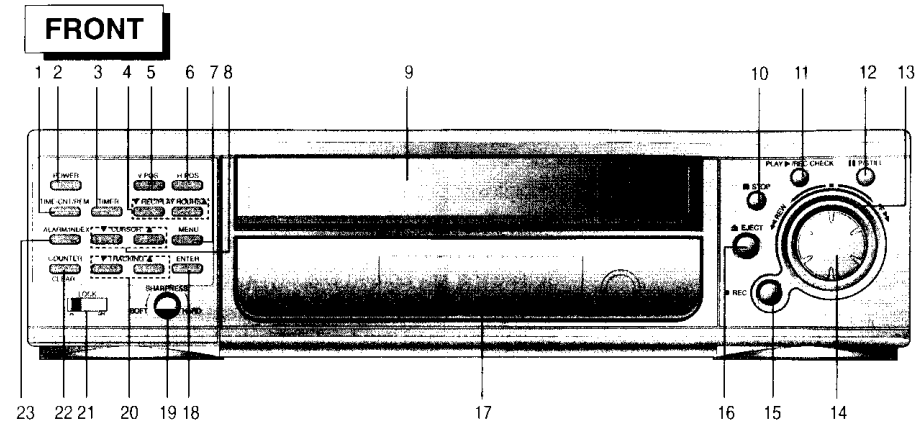

1. **TIME/CNT/REM BUTTON**
To switch among the clock, tape counter and tape remaining time.
2. **POWER BUTTON**
To turn the VCR on and off.
3. **TIMER BUTTON**
To set timer recording.
4. **REC/PLAY HOURS BUTTON**
To change the Play or Record speed to a lower or higher value.
5. **V-POS BUTTON**
To move the position of the Time/Date display in the vertical direction.
6. **H-POS BUTTON**
To move the position of the Time/Date display in the horizontal direction.
7. **MENU BUTTON**
Displays the programming menu on the monitor or TV screen.
8. **CURSOR (UP/DOWN) BUTTONS**
To select the item on the menu.
9. **CASSETTE COMPARTMENT**
Where the video cassette is inserted.
10. **STOP BUTTON**
To stop the tape.
11. **PLAY/REC CHECK BUTTON**
To playback a recorded tape and used for the Record Check function.
12. **P/STILL(PAUSE STILL) BUTTON**
To still playback or to pause recording.
13. **SHUTTLE RING**
To fast forward or rewind the tape.
14. **JOG DIAL**
Rotate to advance or reverse advance video picture while viewing a still picture.
15. **RECORD BUTTON**
To record Video.
16. **EJECT BUTTON**
To eject a stopped cassette.
17. **VCR FUNCTION INDICATOR PANEL**
Details are on page 6.
18. **ENTER BUTTON**
To select items on the menu screen.
19. **SHARPNESS CONTROL**
To adjust the playback quality.
20. **TRACKING (▼/▲) BUTTON**
To adjust the manual tracking.
21. **LOCK ON/OFF SWITCH**
To switch lock and unlock.
22. **COUNTER CLEAR BUTTON**
To set the counter to zero or erase the information on the menu screen.
23. **ALARM INDEX**
To active and deactivate (toggle) the alarm index function.

CONTROL NAMES AND LOCATIONS (cont'd)

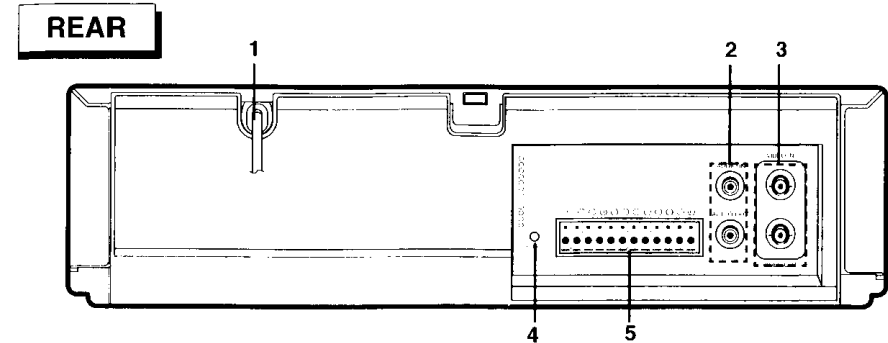

1. **POWER CORD**
Connect only to an AC 100-240V, 50/60Hz outlet.
2. **AUDIO IN/OUT JACK**
Connect the audio input and output terminal.
3. **VIDEO IN/OUT JACK**
Connect the video input and output terminal.
4. **RESET BUTTON**
Use this button to reset the VCR.
5. **12-PIN TERMINAL BLOCK**
Connect external signals.

Terminal Signal Levels

TERMINAL	SIGNAL LEVEL		IN/OUT	
1. ALARM IN	V_{IH}	V_{IL}	VIH: 4-5V, VIL: 0-0.6V T: above 250msec	INPUT
2. ALARM OUT	V_{OH}	V_{OL}	VOH: 4-5V, VOL: 0-0.6V T: ALARM REC STATE	OUTPUT
3. ALARM RESET	V_{IH}	V_{IL}	VIH: 4-5V, VIL: 0-0.6V T: above 250msec	INPUT
5. SERIES IN	V_{IH}	V_{IL}	VIH: 4-5V, VIL: 0-0.6V T: above 250msec	INPUT
6. SERIES OUT	V_{OH}	V_{OL}	VOH: 4-5V, VOL: 0-0.6V T: above 250msec	OUTPUT
7. WARNING OUT	V_{OH}	V_{OL}	VOH: 4-5V, VOL: 0-0.6V T: until any key is pressed	OUTPUT
8. TRIGGER OUT	V_{OH}	V_{OL}	VOH: 4-5V, VOL: 0-0.6V T: above 8-10msec	OUTPUT
10. LOW TAPE OUT	V_{OH}	V_{OL}	VOH: 4-5V, VOL: 0-0.6V T: below 5 min, end of tape	OUTPUT
11. 1-SHOT REC IN	V_{IH}	V_{IL}	VIH: 4-5V, VIL: 0-0.6V T: above 250msec	INPUT
4, 9, 12. GND	-	-	0V	COMMON

CONTROL NAMES AND LOCATIONS (cont'd)

INDICATOR PANEL

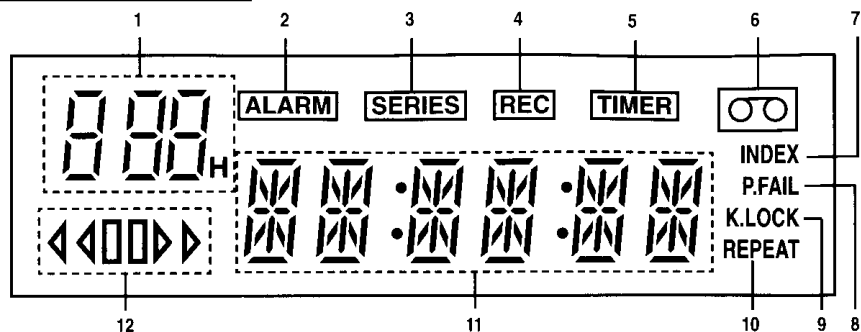

- | | |
|--|---|
| 1. TIME LAPSE VCR TIME Indication | 7. INDEX Indication |
| 2. ALARM Indication
(ALARM REC ON indication) | 8. POWER FAILURE Indication |
| 3. SERIES Indication | 9. KEY LOCK indication |
| 4. RECORD Indication | 10. REPEAT Indication |
| 5. TIMER Indication | 11. FUNCTION Indication
(CLOCK, TAPE COUNTER, ERROR) |
| 6. CASSETTE Indication | 12. VCR FUNCTION Indication |

VCR FUNCTION Indication

PLAYBACK INDICATION		RECORDING INDICATION	
PLAYBACK	▶	RECORDING	▶ REC
PAUSE STILL	▢▢	TIMER RECORDING	▶ REC TIMER
FAST FORWARD	▶▶	ALARM INDEX	▶ INDEX
REWIND	◀◀	ALARM RECORDING	▶ ALARM
FORWARD SLOW PICTURE/ FORWARD FIELD ADVANCE	▶▶	SERIES RECORDING	▶ SERIES
REVERSE SLOW PICTURE/ REVERSE FIELD ADVANCE	◀◀		
CUE	▶▶▶		
REVIEW	▶▶▶		

INSTALLATION

- Connect your VCR's AUDIO/VIDEO output jacks to the A/V input jacks on back of your monitor.
- If your monitor does not have A/V input jacks, exchange the monitor or TV for one with A/V input jacks.
- Connect the CCD camera to VCR's VIDEO input jack.

VCR TO MONITOR AND CCD CAMERA CONNECTION

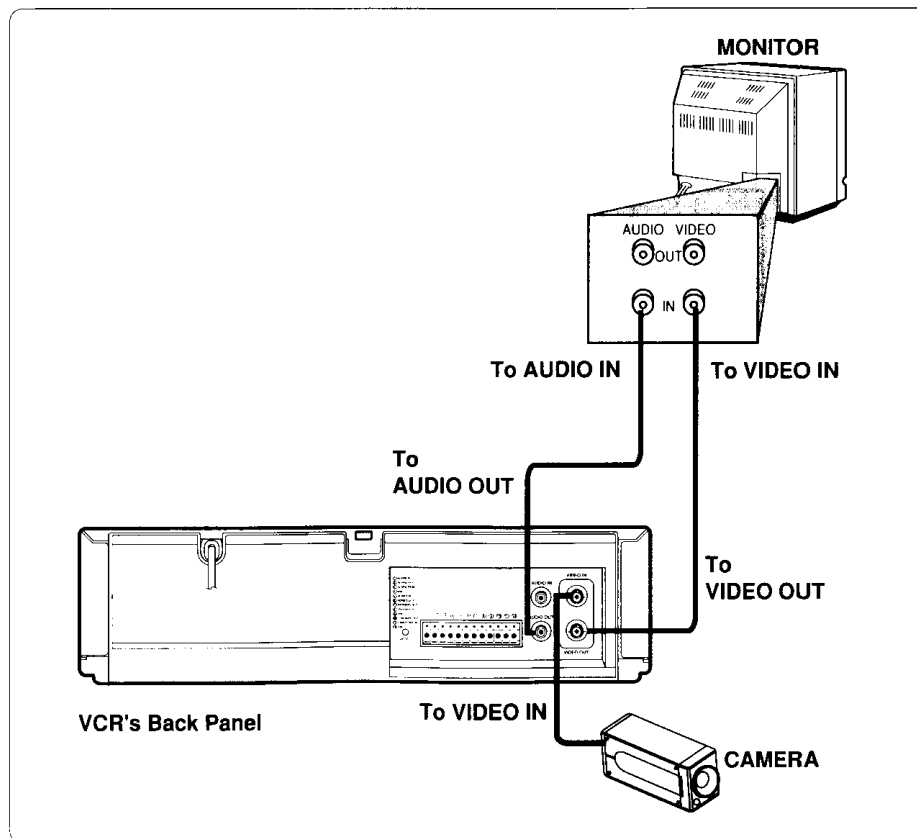

- The cables for audio and video connection are not provided with your VCR.

MULTIPLEXER CONNECTIONS

If the multiplexer has two output terminals (monitor OUT, PB OUT), connect monitor to the PB OUT terminal if you want to see the playback picture.
To use the multiplexer and trigger function properly, refer to the multiplexer instruction manual.

HOW TO CONNECT MULTIPLEXER WITH TRIGGER INPUT TERMINAL

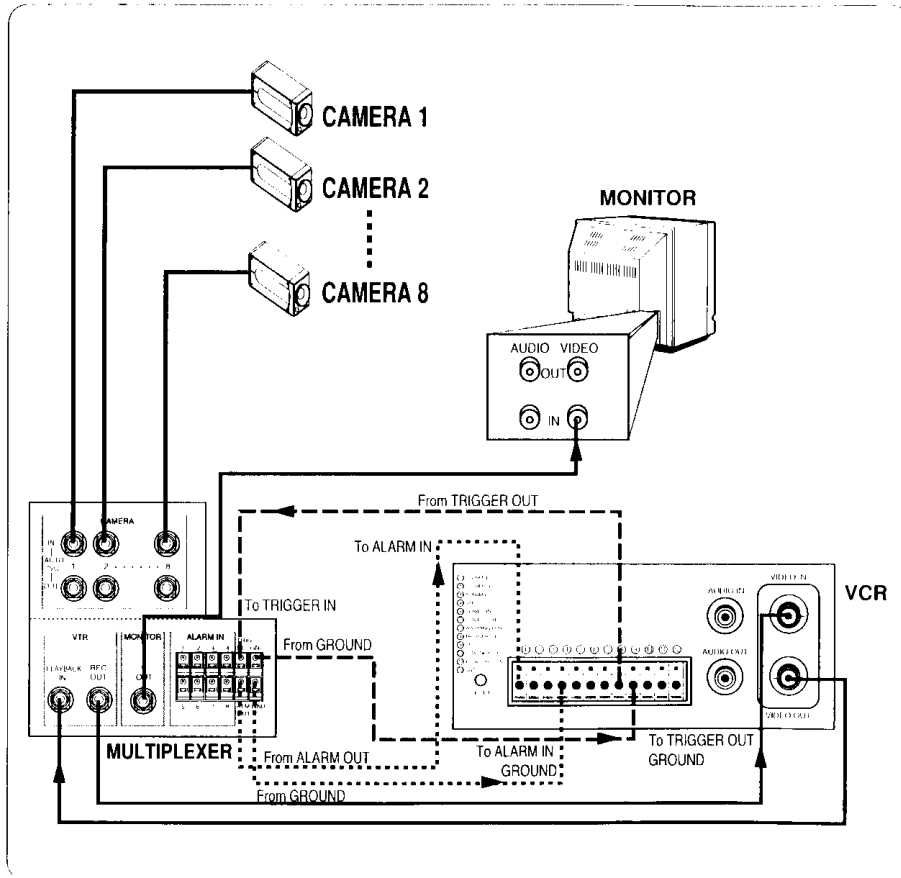

MATRIX SWITCHER CONNECTIONS

HOW TO CONNECT SWITCHER WITHOUT TRIGGER INPUT TERMINAL

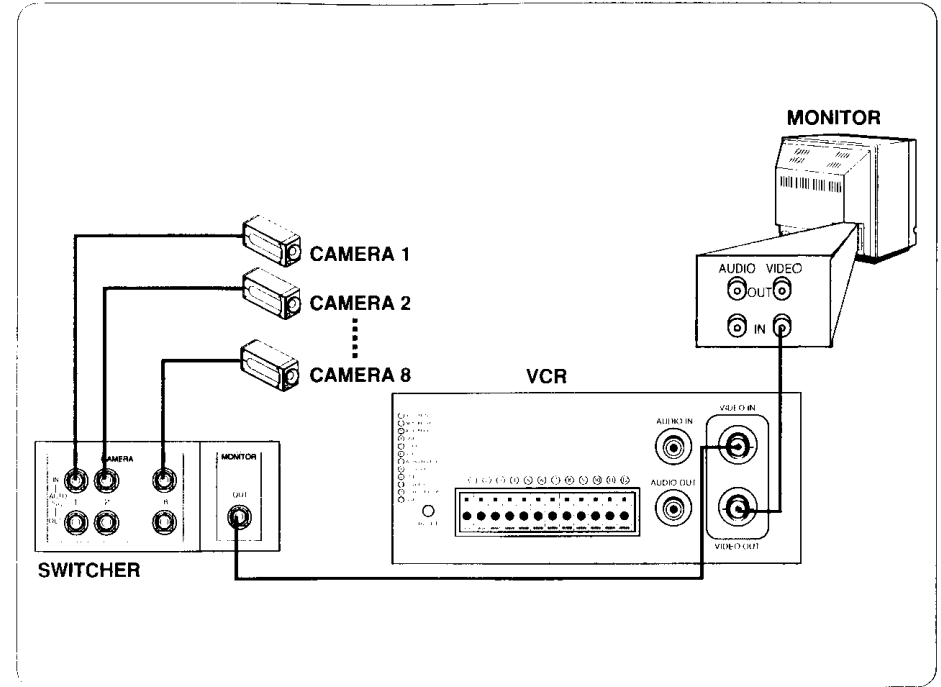

PREPARATION

ALARM RECORD CONNECTION

Connect alarm output of external device to alarm input of VCR, and then connect alarm out GND of device to alarm input GND of VCR.

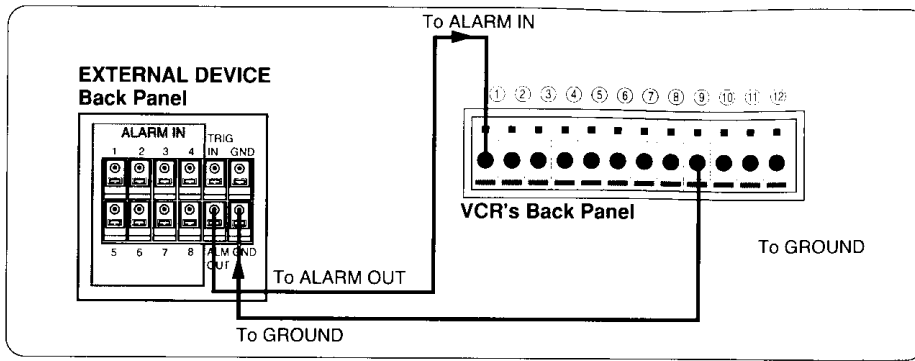

SERIES RECORD CONNECTION

Make all connections to the first VCR before making any connections to the other VCRs in the series.

After connecting, turn on the VCRs and then select the ON: SERIES mode in REC MODE menu. (Refer to the page 22.)

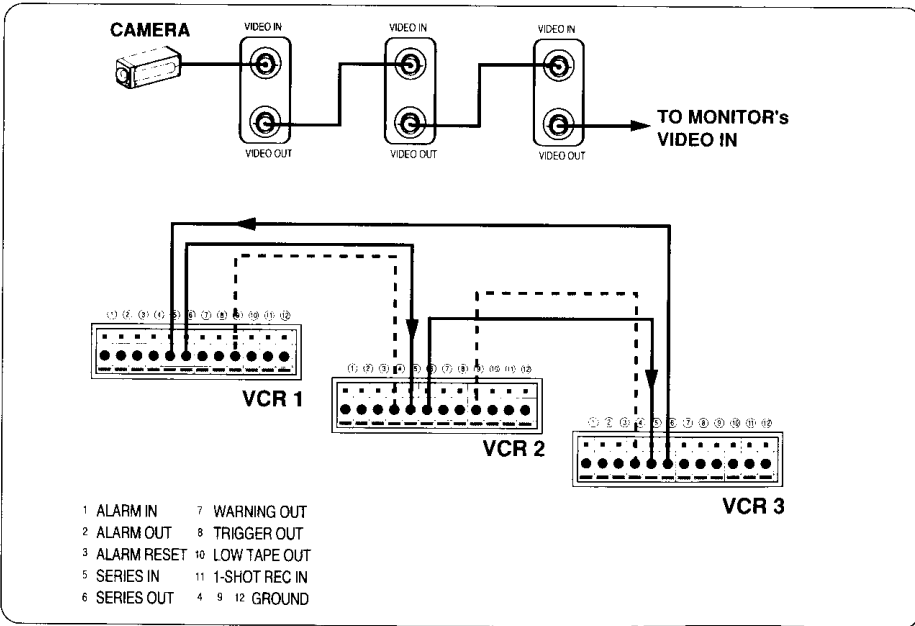

SETTING THE ON SCREEN DISPLAY

The following pages describe the on screen selections to be set.

PREPARATION

- Turn on the power of both the VCR and the monitor.
- If you have a TV instead of monitor, turn on the power of TV and then set the TV's source selector to VIDEO.

MENU SELECTION

Your VCR allows adjustment of several features.

1 Press **MENU** button and the main menu will appear.

2 Select the desired menu with the **UP** or **DOWN** button and then press the **ENTER** button.

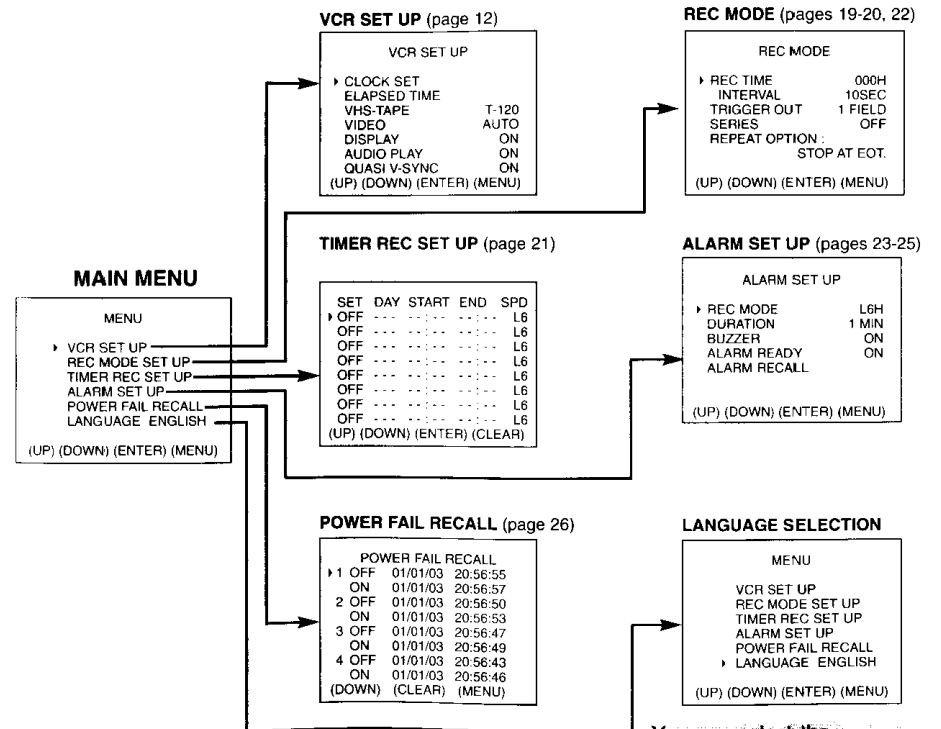

You can select the language among **ENGLISH, FRANCAIS, DEUTSCH, ITALIANO, ESPAÑOL, POLSKI** and **ニホンゴ**.

SETTING THE SETUP MENU

MAIN MENU

```

MENU
▶ VCR SET UP
REC MODE SET UP
TIMER REC SET UP
ALARM SET UP
POWER FAIL RECALL
LANGUAGE ENGLISH
(UP) (DOWN) (ENTER) (MENU)
    
```

SETUP MENU

```

VCR SET UP
▶ CLOCK SET
ELAPSED TIME          T-120
VHS-TAPE              AUTO
VIDEO                 ON
DISPLAY              ON
AUDIO PLAY            ON
QUASI V-SYNC         ON
(UP) (DOWN) (ENTER) (MENU)
    
```

Press **UP** or **DOWN** to choose a desired item on the **SETUP** menu.

Recording Time Table

Recording time mode displayed on OSD & FLD	T-120	T-160	T-180	T-210
L6H	L8H	L9H	L10H	
L18H	L24H	L27H	L31H	
L30H	L40H	L45H	L52H	
72H	104H	117H	136H	
96H	136H	153H	178H	
120H	168H	189H	220H	
168H	232H	261H	304H	
240H	328H	349H	430H	
480H	648H	729H	850H	
960H	1288H	1449H	1690H	
000H	000H	000H	000H	

```

ELAPSED TIME
DATE OF FIRST USE:
01/01/03
PERIOD IN USE:
00004 HOURS
(MENU)
    
```

```

VCR SET UP
CLOCK SET
ELAPSED TIME
▶ VHS-TAPE          T-120
VIDEO              AUTO
DISPLAY            ON
AUDIO PLAY         ON
QUASI V-SYNC      ON
(UP) (DOWN) (ENTER) (MENU)
    
```

PREPARATION

- Turn on the power of both the VCR and the monitor.
- If you have a TV instead of monitor, turn on the power of TV and then set the TV's source selector to VIDEO.

1 Press **MENU** button. The main menu will appear. Press **DOWN** or **UP** to choose VCR SET UP.

2 Press **ENTER** button. The VCR SET UP menu will appear.

1. CLOCK SET

Details are on page 13.

2. ELAPSED TIME

Check the used time of head by pressing **ENTER**.

3. VHS-TAPE

Choose the tape type used (T-120, T-160, T-180, T-210) by pressing **ENTER**.

Recording time mode on OSD & FLD is changed by selecting the tape type.

Refer to the left recording time table. (*L : Linear Mode)

The selection of tape is supposed to 'T-120' on this manual.

4. VIDEO

Choose the camera's color type (B/W, AUTO, COLOR) by pressing **ENTER**.

5. DISPLAY

The time/date **DISPLAY** is switched between ON and OFF by pressing **ENTER**.

6. AUDIO PLAY

The audio is switched between ON and OFF during playback by pressing **ENTER**.

7. QUASI-SYNC

The quasi-sync is switched between ON and OFF during playback by pressing **ENTER**.

SETTING THE SET TIME

Things to know before starting

- The clock uses the 24-hour system.
- The initial SET DAY Setting is **JANUARY 1, 2003**.

PREPARATION

- Turn on the power of both the VCR and the monitor.
- If you have a TV instead of monitor, turn on the power of TV and then set the TV's source selector to VIDEO.

1 Press **MENU** button. The main menu will appear.

2 Press **DOWN** or **UP** to select the SET UP item and then press **ENTER**. The SET UP menu will appear.

3 Press **DOWN** or **UP** to select the CLOCK SET item and then press **ENTER**. The CLOCK SET UP menu will appear.

Example: May 23, 2003 ; 17:30

4 Press **ENTER** and then **DOWN** or **UP** to set a month and then press **ENTER** to move to day item.

5 Repeat step 4 to select the day, year and time.

The day of the week will display automatically.

6 Press **MENU** button when finished.

MAIN MENU

```

MENU
▶ VCR SET UP
REC MODE SET UP
TIMER REC SET UP
ALARM SET UP
POWER FAIL RECALL
LANGUAGE ENGLISH
(UP) (DOWN) (ENTER) (MENU)
    
```

VCR SET UP MENU

```

VCR SET UP
▶ CLOCK SET
ELAPSED TIME          T-120
VHS-TAPE              AUTO
VIDEO                 ON
DISPLAY              ON
AUDIO PLAY            ON
QUASI V-SYNC         ON
(UP) (DOWN) (ENTER) (MENU)
    
```

CLOCK SET UP MENU

```

CLOCK SET UP
MM/DD/YY
▶ DATE 05 / 23 / 03 FRI
HH/MM/SS
TIME 17 / 30 / 00
(UP) (DOWN) (ENTER) (MENU)
    
```

```

L12H
17:30:00
05/23/03
    
```

(TV screen/monitor)

VIDEO CASSETTE TAPES

SAFETY TAB

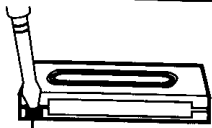

To prevent accidental erasure, remove the tab after recording.



To record again, cover the hole with vinyl tape.

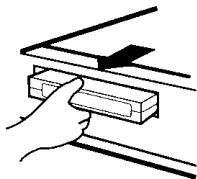
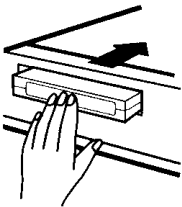

WHEN HANDLING VIDEO CASSETTES

- Do not expose video cassettes to extreme heat, high humidity, or strong magnetic fields.
- Do not tamper with the cassette mechanism.
- Do not touch the tape with your fingers.
- Always store an unused cassette in its case.

LOADING

Hold the cassette with the arrow side up (top). Insert the cassette gently into the slot in the direction of the arrow (on the cassette) until the loading mechanism automatically pulls the cassette into the unit. Make certain that the cassette is inserted correctly.

- If the cassette is not loaded correctly, the VCR will eject the cassette automatically after approximately 3 seconds.

UNLOADING

Press the **STOP/EJECT** button twice. The cassette will be ejected automatically. After the cassette is visible in the tape slot, pull it out to remove it.

- Unloading the cassette is possible only when the power cord is connected to the wall outlet.
- The cassette can be ejected when the **STOP/EJECT** button is pressed, even if the VCR's power is OFF.

NORMAL PLAYBACK



PREPARATION

- Turn on the power of both the VCR and the monitor.
- If you have a TV instead of monitor, turn on the power of TV and then set the TV's source selector to VIDEO.

NORMAL PLAYBACK

1 Insert a prerecorded video cassette.

The  indicator will light and the VCR will power-up automatically.

- If a tape without a record protect tab is inserted, the unit will start the playback automatically.

2 Press the **PLAY** button.

Press **REC/PLAY HOURS** ▼ or ▲ button to choose the desired time mode.

The selected time is displayed in the VCR indicator panel. Select the time while the tape is stopped or being played back.

L6H → L18H → L30H → 72H → 96H → 120H → 168H → 240H → 480H → 960H

- The time mode can not be changed while the tape is playing back in L2H and L4H.
- If the tape reaches the end before STOP is pressed, the VCR will automatically stop and rewind.

3 Press the **STOP** button to stop playback.

TRACKING CONTROL

If noise appears on the screen during playback, press either **TRACKING** (▲/▼) buttons until the noise on the screen is reduced.

- In case of vertical jitter, adjust these controls very carefully.
- Tracking is automatically reset to normal when the tape is ejected.

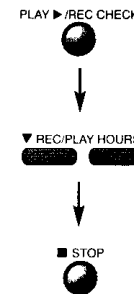

NOTES:

- A picture may vibrate vertically, but this is normal.
- A distortion may appear on the top of the screen, but this is normal.
- A sound may be muted during playback, but this is normal.
- If the recording hour and playback hour are different, the sound may not play back normally. (Set the AUDIO PLAY on the SETUP menu to OFF mode.)

SPECIAL EFFECTS PLAYBACK

TO WATCH A STILL PICTURE

During **PLAYBACK** mode...

1 Press the **P/STILL** button.

Still picture will appear on the monitor.

- If a still picture vibrates vertically, stabilize it by pressing the **TRACKING** (▼/▲) buttons.
- If the VCR is left in the STILL mode for more than 5 minutes, the VCR will automatically enter the STOP mode to protect the tape and video heads.

2 To continue normal playback, press the **PLAY** button.

TO WATCH A FIELD ADVANCE PICTURE

During **PLAYBACK** mode...

1 Press the **P/STILL** button.

2 Rotate the **JOG** dial to forward or reverse.

The picture will slowly advance to forward or reverse field by field.

3 To continue normal playback, press the **PLAY** button.

TO SEARCH ALARM RECORDING

During **STOP** mode...

1 Press the **ALARM INDEX** button.

2 Rotate the **SHUTTLE** ring to forward or reverse.

The **INDEX** indicator will appear in the VCR indicator panel. Alarm video will play for 5 seconds and then search to the next alarm recording.

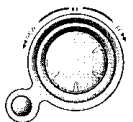
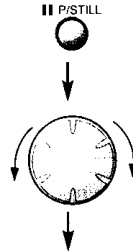

PLAYBACK

SPECIAL EFFECTS PLAYBACK (cont'd)

SHUTTLE RING

During **Still** mode...

1 Rotate the **Shuttle Ring** to forward or reverse.

2 Rotate **Shuttle Ring** toward **FF** to advance the tape, or toward **REW** to reverse the tape. How far you rotate and hold the shuttle ring determines the speed at which the tape moves.

Rotate **Shuttle Ring** for variable speed adjust from Slow to Search in the direction chosen.

3 Release the **Shuttle Ring** to return to **STILL** mode.

4 Press **PLAY** to return to normal playback speed.

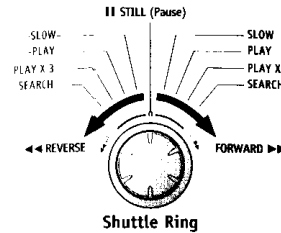

NOTES:

- During **STOP** mode, rotate and release the Shuttle ring to rewind or fast forward the tape.
- If the Shuttle Ring is used during the normal playback, the playback mode is changed between the double speed play and forward search on the forward direction, and among the reverse play, reverse triple-speed play, and reverse search on the reverse direction. Releasing the ring resumes a normal playback mode.

JOG DIAL

During **Still** mode...

1 Move **Jog Dial** with finger toward **FF** to advance tape **frame-by-frame**, or toward **REW** to reverse tape **frame-by-frame**. Movement of the **Jog Dial** one "click" moves the tape by one frame. How "fast" you move the **Jog Dial** determines how fast the frame-by-frame movement occurs.

2 Press **PLAY** to return to normal playback speed.

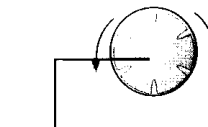

Jog Dial

Move Jog Dial for frame-by-frame tape playback forward or reverse.

NOTES:

- Horizontal lines (noise bars) will appear on the monitor screen, but this is normal.
- The audio is automatically muted during special effect modes, so there is no sound during search.
- During the high-speed picture search modes, a short period is needed to stabilize tape speed when re-entering the **PLAY** mode. Slight interference may be observed during this period.

PLAYBACK

TAPE COUNTER MEMORY FEATURE

REAL TIME COUNTER

During **PLAYBACK** or **RECORDING** mode...
Press the **TIME/CNT/REM** button.

Whenever you press the **TIME/CNT/REM** button, time and counter are displayed alternately in the VCR indicator panel.

When the **COUNTER** is displayed...

- Counter changes to **TIME** when the cassette is ejected.
- The real-time counter does not operate when nothing is recorded on the tape.

COUNTER MEMORY FUNCTION

This function is only provided when **COUNTER** is displayed in the VCR indicator panel.

1 Begin recording or playing a tape.

Continue to play or record.

2 At the point where you want playback to begin, reset the real-time counter to 0:00:00 by pressing the **COUNTER CLEAR** button.

3 Press the **STOP** button when recording or playback finishes.

4 Rotate and release the **SHUTTLE** ring to reverse.

The VCR will stop at the **COUNTER** position 0:00:00.

TAPE REMAINING

This function allows the time of the remaining tape to be displayed during recording or playback.

1 Press the **TIME/CNT/REM** button until the remaining time displays on the VCR indicator panel.

2 Start recording or playback.

- The remaining time is not display during more than "72H" recording mode.

NORMAL RECORDING

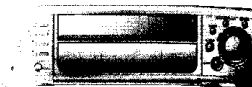

PREPARATION

- Turn on the power of both the VCR and the monitor.
- If you have a TV instead of monitor, turn on the power of TV and then set the TV's source selector to VIDEO.

1 Insert the **VIDEO CASSETTE** that has safety tab in place.

2 Press **REC/PLAY HOURS** to choose the desired recording mode.

The selected time is displayed in the VCR indicator panel.

L6H → L18H → L30H → 72H → 96H → 120H → 168H → 240H → 480H → 960H → 000H

- If you select the "000H" REC TIME, the INTERVAL time mode is changed on the REC MODE SET UP menu as below, to the second unit.

10 SEC → 20 SEC → 30 SEC → 1 MIN → 2 MIN → 3 MIN → AUTO

- If you select AUTO, this unit records when the external 1-SHOT REC signal is input.

3 Press the **REC** button.

Recording will start.
(The REC indicator will appear in the VCR indicator panel.)

4 Press the **STOP** button to stop recording.

To PAUSE the recording

During the **RECORDING** mode...

1 Press the **P/STILL** button to pause the tape.

2 When you want to continue recording, press the **P/STILL** button again.

- After 5 minutes in pause mode, the tape will be stopped automatically to protect the tape and the video heads.

To Record Check

When in record mode, pressing the **REC CHECK** should cause the unit to reproduce recently recorded video.

During the **RECORDING** mode...

Press **REC CHECK** to reproduce recently recorded video. During the **Record Check**, the unit can't record at all. After the **Record Check**, the unit returns to the original recording mode.

PLAYBACK

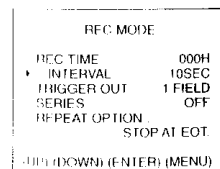
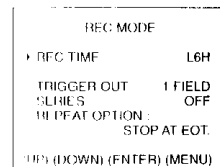
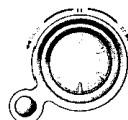
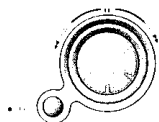
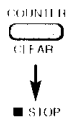
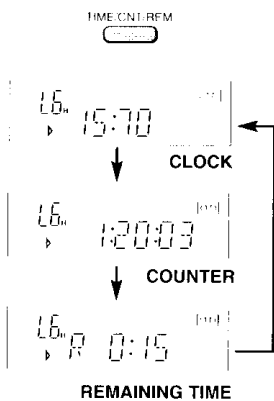

RECORDING

REPEAT RECORDING



This function is used to select various options before starting a recording.

Things to know before starting

- Make sure a tape is in the each VCR and the safety tab is in place otherwise, the tape will be automatically ejected.
- Turn on the power of both the VCR and the monitor.

MAIN MENU

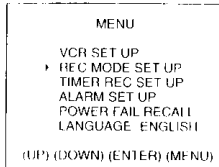

REC MODE MENU

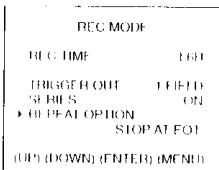

- 1 Press **MENU** button and the main menu will appear.
- 2 Press the **DOWN** or **UP** to select **REC MODE SET UP**. Press **ENTER**. The **REC MODE** menu will display.
- 3 Press **DOWN** or **UP** to choose the **REPEAT OPTION** item. Press **ENTER** repeatedly to choose options.
 - **STOP AT EOT**: Goes into **STOP** mode when it reaches end of tape in **RECORD** mode.
 - **RE-REC EVEN IF ALARM**: Rewinds tape and enters **RECORD** mode at beginning of tape even if there has been alarm.
 - **REWIND, STOP**: Rewinds tape and then enters **STOP** mode.
 - **STOP IF ALARM**: If there has been alarm, it goes into stop mode when it reaches end of tape in record mode. Otherwise it operates same as **RE-REC** even if alarm mode.

4 Press **MENU** when finished. Press **MENU** repeatedly to exit menu screen.

5 Press **REC** button.
The VCR will start recording.

- We do not recommend repeat recording for security applications.



• REC

TIMER RECORDING

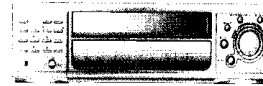

This VCR can be programmed to record up to 8 programs. For programmed recording, the timer must be set for the starting and ending times.

PREPARATION

- Make sure a tape is in the VCR and the safety tab is in place, otherwise the tape will be automatically ejected.
- Turn on the power of both the VCR and the monitor.
- If you have a TV instead of monitor, turn on the power of TV and then set the TV's source selector to **VIDEO**.

1 Press **MENU** and the main menu will appear.

2 Press the **DOWN** or **UP** to choose the **TIMER REC SET UP** item.

3 Press **ENTER** to enter the **TIMER REC SET UP** menu.

The **TIMER REC SET UP** menu will appear.

4 Press **ENTER** to select the **SET** item then press **DOWN** or **UP** to choose **ON** or **OFF**. Activated **Timer Recording** only when the **SET** item set to "ON".

5 Press **ENTER** to move to next item and then set the next items (day, start time, end time, recording hour) by using **UP**, **DOWN** and **ENTER** buttons.

DAY option

SUN~SAT: Same time once a week.

M-F or S-S: Same time during Monday ~ Friday or Saturday ~ Sunday

DLY: Same time(s) every day

6 Press **MENU** when finished. Press **MENU** repeatedly to exit menu screen.

MAIN MENU

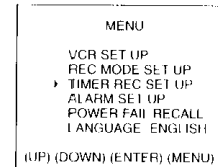

TIMER REC MODE MENU

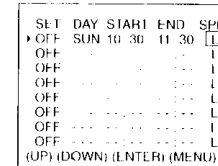
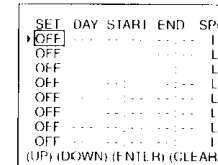

NOTES:

- If you want to stop recording during the **Time recording**, press **STOP** button more than 3 seconds.
- If you press **TIMER** button, the Time Lapse's power is turned off. After finishing **Time recording**, the Time Lapse's power is turned off again.

If you are finished programming and you want to set the VCR to record the programs you have entered. **A) MAKE SURE YOU HAVE INSERTED A TAPE INTO THE VCR. B) YOU MUST PRESS TIMER BUTTON BEFORE IT WILL RECORD ANY TIMER PROGRAMS (TIMER appears).** The VCR is now set to record the preset programs.

RECORDING

SERIES RECORDING



Series Recording mode is convenient when you record with two or more VCRs. If you have two VCRs in series recording mode, the second VCR will start to record automatically at the end of the first VCR recording.

Things to know before starting

- Before series recording, refer to page 10 for Series Record connection.
- Make sure a tape is in the each VCR and the safety tab is in place.
- SERIES recording is not available when the Timer recording is in standby mode.
- SERIES and REPEAT OPTION on the REC MODE menu can not be set to ON mode simultaneously.

MAIN MENU

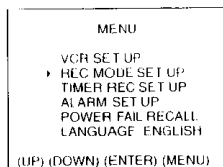

(UP) (DOWN) (ENTER) (MENU)

REC MODE MENU

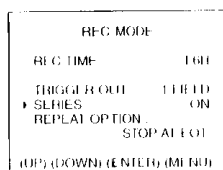

(UP) (DOWN) (ENTER) (MENU)

1 Press **MENU** button and the main menu will appear.

2 Press **DOWN** or **UP** to choose the REC MODE SET UP item and then press **ENTER**.

The REC MODE SET UP menu will appear.

3 Press the **DOWN** or **UP** to choose the SERIES item. Press **ENTER** to choose ON.

4 Press **MENU** when finished. Press **MENU** repeatedly to exit menu screen.

5 Press **REC** button.
The first VCR will start recording.

ALARM RECORDING



Alarm recording will start when the external alarm signal is input. This function is available when VCR is connected with an external device having an alarm output terminal.

Things to know before starting

- Before alarm recording, refer to page 10 for Alarm Record connection.
- Make sure a tape is in the VCR and the safety tab is in place.

MAIN MENU

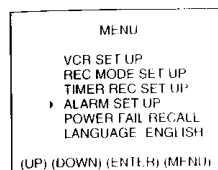

(UP) (DOWN) (ENTER) (MENU)

ALARM SET UP

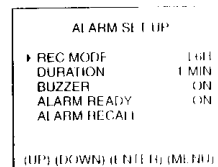

(UP) (DOWN) (ENTER) (MENU)

1 Press **MENU** and the main menu will appear

2 Press the **DOWN** or **UP** to choose the ALARM SET UP item and then press **ENTER**.

The ALARM SET UP menu will appear.

3 Press the **DOWN** or **UP** to choose the REC MODE item. Press **ENTER** repeatedly to choose recording hours.

The recording mode is changed as below.

OFF → L6H → L18H → L30H

4 Press **DOWN** to choose the DURATION item. Press **ENTER** repeatedly to choose the desired duration of recording.

The duration of recording is changed as below.

30 SEC → 1 MIN → 3 MIN → 5 MIN → 10 MIN → T.END → AUTO

- If you choose the T.END, alarm recording continues until tape ends.
- If you choose AUTO, alarm recording continues until the alarm reset signal is input.

ALARM RECORDING (cont'd)

ALARM SET UP

```

ALARM SET UP
REC MODE          L6H
DURATION          1 MIN
BUZZER            ON
ALARM READY      ON
ALARM RECALL
    
```

(UP) (DOWN) (ENTER) (MENU)

```

ALARM SET UP
REC MODE          L6H
DURATION          1 MIN
BUZZER            ON
ALARM READY      ON
ALARM RECALL
    
```

(UP) (DOWN) (ENTER) (MENU)

5 Press **DOWN** to choose the BUZZER item. Press **ENTER** repeatedly to switch buzzer function during alarm recording.

- While the alarm is in process, the buzzer will ring. If you want to stop buzzer, press any button.

6 Press **DOWN** to choose the ALARM READY item. Press **ENTER** repeatedly to switch alarm ready function.

- When selected "ON" and the alarm input is triggered, the unit will go to alarm record mode from either STOP, POWER OFF or RECORD modes.
- When selected "OFF" and the alarm input is triggered, the unit will go to alarm record mode only from the RECORD mode (including Timer Record). If the unit is in STOP or POWER OFF mode, it will ignore the alarm input command.

7 Press **MENU** when finished. Press **MENU** repeatedly to exit menu screen.

- ALARM indicator in VCR indicator panel blinks when alarm recording is proceeding.

NOTES:

- When you select ALARM REC MODE ON (L6H, L18H, L30H), the ALARM indicator will light in VCR indicator panel.
- You can not stop during ALARM REC MODE.

For example: When the Alarm REC MODE is set to L6H

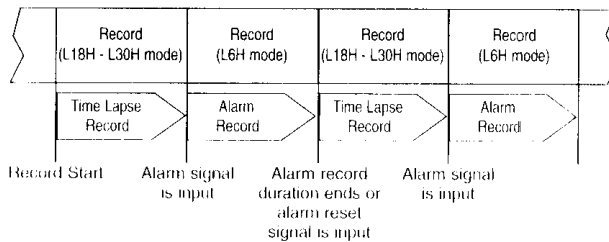

CHECK THE ALARM RECORD INFORMATION

MAIN MENU

```

MENU
VCR SET UP
REC MODE SET UP
TIMER REC SET UP
ALARM SET UP
POWER FAIL RECALL
LANGUAGE ENGLISH
    
```

(UP) (DOWN) (ENTER) (MENU)

ALARM REC MODE MENU

```

ALARM SET UP
REC MODE          L6H
DURATION          1 MIN
BUZZER            ON
ALARM READY      ON
ALARM RECALL
    
```

(UP) (DOWN) (ENTER) (MENU)

```

ALARM RECALL
1 01/01/03 00:21:13
2 01/02/03 04:07:37
3 01/03/03 03:59:36
4 -:-:-:-:-
5 -:-:-:-:-
6 -:-:-:-:-
7 -:-:-:-:-
8 -:-:-:-:-
    
```

(UP) (DOWN) (CLEAR) (MENU)

To check or cancel the Alarm Record Information, use the ALARM RECALL function.

1 Press **MENU** button and the main menu will appear

2 Press **DOWN** or **UP** to choose the ALARM SET UP item and then press **ENTER**.

ALARM SET UP menu will appear.

3 Press **DOWN** or **UP** to choose the ALARM RECALL item and then press **ENTER**.

ALARM RECALL menu will appear.

To erase the alarm record inform

If you want to erase the alarm record information, press the **CLEAR** button.

4 Press **MENU** when finished. Press **MENU** repeatedly to exit menu screen.

NOTES:

- Alarm Recall can memorize up to 16 alarms, but only 8 can be displayed on the monitor. Press **DOWN** repeatedly to see the next page.

RECORDING TIME TABLE INFORMATION

Recording Time	Field / sec
L6H	60
L18H	20
L30H	12
72H	4.62
96H	3.53
120H	2.86
168H	2.07
240H	1.46
480H	0.74
960H	0.37

CHECK THE POWER FAIL RECALL

To check or cancel the POWER FAIL RECALL while you are recording, use the POWER FAIL RECALL function.

MAIN MENU

MENU
VCR SET UP
REC MODE SET UP
TIMER REC SET UP
ALARM SET UP
▶ POWER FAIL RECALL
LANGUAGE ENGLISH
(UP) (DOWN) (ENTER) (MENU)

POWER FAIL INFORM MENU

POWER FAIL RECALL
1 OFF 01/01/03 20:56:55
ON 01/01/03 24:00:00
▶ 2 OFF 03/15/03 12:25:50
ON 03/15/03 16:56:53
3 OFF --/--/-- --:--:--
ON --/--/-- --:--:--
4 OFF --/--/-- --:--:--
ON --/--/-- --:--:--
(UP) (DOWN) (CLEAR) (MENU)

1 Press **MENU** and the main menu will appear.

2 Press **DOWN** or **UP** button to choose the **POWER FAIL RECALL** item.

3 Press **ENTER** to enter the **POWER FAIL RECALL** menu. **POWER FAIL RECALL** menu will appear.

- Power fail information will display up to 8 occurrences.

To erase the power fail recall

If you want to erase the power fail recall, select a power fail recall item to erase and then press the **CLEAR** button. The power fail recall is erased.

4 Press **MENU** when finished. Press **MENU** repeatedly to exit menu screen.

SELF-DIAGNOSIS

This function informs you of error messages to help solve problems more easily.

When the VCR malfunctions, an error code is displayed in the VCR indicator panel.

ERROR CODE TABLE

DISPLAY	DESCRIPTION	INPUT SIGNAL	CIRCUIT STATUS	SERVICE POINTS
E-1	Loading Motor Error	• Mode Switch S1,S2,S3,S4 • Load Motor +, -	• Mode Switch Position not changed within 6 seconds after cassette loading attempt.	• Loading Motor Drive IC • Loading Motor • Mode Switch
E-2	Tape Loading Error	• Mode Switch S1,S2,S3,S4 • Load Motor +, -	• Mode Switch Position not changed within 6 seconds after cassette loading attempt.	• Mode Switch contacts
E-3	Tape Eject Error	• Mode Switch S1,S2,S3,S4 • CST IN Switch • Load Motor +, -	• CST Switch must be activated within 3 seconds, otherwise unit shut down will occur.	• CST IN Switch contacts
E-4	Reel Rotational Error	• Supply/Take-up Reel Pulses • CFG	• CFG Signal present, but take-up pulses are missing. (Capstan motor running.)	• Capstan belt • Idler and reel gears damaged
E-5	Drum Motor Error	• DFG Switch • DPF	• Drum Motor (Slow Start) • Motor must be up to speed within 3 seconds of operation.	• Drum Motor and Control Circuits

- When a malfunction occurs in the VCR, press the **POWER** button on the front of VCR to operate normally.
- An error message (Err) appears in the display continuously when any button is pressed; contact your dealer or service center.

USE TO LOCK ON/OFF SWITCH

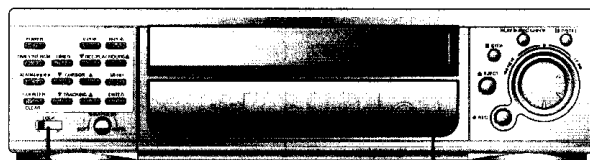

LOCK ON/OFF switch

LOCK indicator

- To protect unauthorized persons using the VCR, select **LOCK** switch to **ON**. Other buttons do not operate.
- Switch **LOCK** switch to **OFF** to reactivate VCR buttons.

SERVICE GUIDE TABLE

Unit is Hour.

NO.	DESCRIPTION	1500	3000	5000	6000	7500	9000	10000	12000
1	DRUM ASSY	●	●	◆	●	●	●	◆	●
2	MOTOR CAPSTAN (D-35)	●	●	●	◆	●	●	●	◆
3	BELT CAPSTAN								◆
4	BASE ASSY A/C	●	●	●	●	●	●	●	◆
5	HEAD F/E	●	●	●	●	●	●	●	◆
6	ARM ASSY IDLER							◆	
7	HOLDER ASSY PINCH				◆				◆
8	BAND ASSY TENSION								◆
9	HOUSING ASSY	▲	▲	▲	▲	▲	▲	▲	◆
10	CAPSTAN SOFT BRAKE				◆				◆

Reference:

◆: Changing ●: Cleaning ▲: Checking



Notes:

- Check the running path adjustment when you change items 1, 2, 4, 5 and 10.
- Check the back tension when you change Band Assy Tension.

VIDEO HEAD CLEANING

- Dirt accumulating on the head after a long period of time can cause the playback picture to become blurred or broken up. High quality video cassette tapes will not normally deposit dirt onto the video head, but old or damaged tapes might. Clean the video heads with a commercially available video heads cleaning tape.

TROUBLESHOOTING

SYMPTOM	CHECK POINT & CORRECTION
Cassette cannot be inserted.	<ul style="list-style-type: none"> • Load cassette in direction indicated by arrow on cassette. • A cassette is already in the VCR. • Check if power indicator is lit on the VCR indicator panel. If not, make sure power cord is plugged in. • If the  indicator flashes, press the POWER button again.
The VCR will not go into the recording mode, even when REC button is pressed.	<ul style="list-style-type: none"> • The cassette has had the erase prevention tab removed. Stick a piece of cellophane tape over the erase prevention tab hole or select a different cassette.
No picture appears on monitor screen when PLAY button is pressed.	<ul style="list-style-type: none"> • Try a different cassette tape. • Try to confirm that the system is connected correctly.
No picture, but audio is clear.	<ul style="list-style-type: none"> • The heads may require cleaning. • Take VCR to a qualified Service Center for service.
Interference on playback picture.	<ul style="list-style-type: none"> • Adjust fine tuning knob on monitor to obtain best picture. • Adjust TRACKING (▼/▲) control button. • Take VCR to Service Center for service.
VCR does not start at preset record starting time.	<ul style="list-style-type: none"> • Setup recording time according to instructions.
The tape is ejected in the timer or alarm recording mode.	<ul style="list-style-type: none"> • The cassette has had the erase prevention tab removed. Stick a piece of cellophane tape over the erase prevention tab hole or select a different cassette.
 indication flashes.	<ul style="list-style-type: none"> • Insert a cassette.

Using the **RESET** button (located at the rear panel of VCR)

This button is used to solve the problems exhibited by the following symptoms :

- When the power cannot be turned on, even if the power cord is connected to the outlet.
- When the VCR's display does not display.
- When the VCR does not operate normally.
- Use a pencil or ballpoint pen to press the **RESET** button.

NOTES:

- If the **RESET** button is pressed, present time is cleared, then set the clock again.

SPECIFICATIONS

GENERAL

Head System	Four head helical scan azimuth system
Power Source	AC 100-240V, 50/60Hz
Power Consumption	Approx. 15 watts
Back up time (clock)	30 days
Dimensions (WxHxD)	14.2" x 3.7" x 10.7" (360 x 94 x 273 mm)
Operating Temperature	41 °F~105 °F (5 °C~40 °C)
Operating Humidity	Less than 80% RH
Timer	24-hour display type
Weight	Approx. 8.4 lb (3.8 kg)
Tape Speed	11.12 mm/sec (L6H), 3.70 mm/sec (L18H), 2.22 mm/sec (L30H), 72H~960H
Maximum Recording Time	6 hours (T-120, L6H), 18 hours (T-120, L18H), 30 hours (T-120, L30H), 72H~960H
Tape Width	0.5 in. (12.7 mm)
Rewind Time	About 65 seconds (T-120)
Video Signal System	EIA Standard (525 lines, 60 fields) NTSC type color signal
Video Input	1.0 Vp-p 75 ohms unbalanced
Video Output	1.0 Vp-p 75 ohms unbalanced
Signal to Noise Ratio	More than 43 dB (L6H mode)
Conventional audio	
Input (LINE)	-6.0 dBm more than 47 kohms
Output (LINE)	-6.0 dBm less than 1.5 kohms
S/N Ratio	More than 43 dB (L6H mode)
Frequency Range	200 Hz to 10kHz (L6H mode)

* Designs and specifications are subject to change without notice.

* Weight and dimensions shown are approximate.